

**Government of India
Ministry of Jal Shakti,
Department of Water Resources, River Development and
Ganga Rejuvenation
Central Ground Water Board Bhujal Bhawan, NH-IV,
Faridabad, Pin - 121001**

E-TENDER INQUIRY

**FOR CONSTRUCTION OF PIEZOMETERS 810 NOS IN SOFT ROCK/
HARD ROCK AND SUPPLY, INSTALLATION, COMMISSIONING OF
DWLRS AND TELEMETRY, ESTABLISHMENT OF DATA ACQUISITION
SYSTEM & ITS MAINTENANCE FOR REAL TIME GROUND WATER
LEVEL MONITORING AND SUPPLY OF GROUND WATER LEVEL,
GROUND WATER TEMPERATURE DATA FROM SITE AND RECEIPT OF
DATA AT NATIONAL DATA CENTRE, CHQ, FARIDABAD, IN A DESIRED
FORMAT FROM 810 NOS CONSTRUCTED PIEZOMETERS WELLS
THROUGH TELEMETRY SYSTEMS WITH 05 YEARS WARRANTY AND
02 YEARS AMC IN STATES OF UTTARPRADESH, BIHAR, JHARKHAND,
WEST BENGAL AND ODISHA**

e-Tender Inquiry Number : NIET No. 12/2022-23/MMS-I

TENDER DOCUMENT

INDEX

Section		Contents	Page
Section	A.	Cover Page	1
Section	B.	INDEX	2
Section	I.	Notice Inviting e-Tenders (NIT)	3 – 5
Section	II.	Instructions to Bidders (ITB)	6 – 21
Section	III.	General Conditions of Contract (GCC)	22 – 49
Section	IV.	Special Conditions of Contract (SCC)	50 – 70
Section	V.	Scope of Work and Technical Specifications	71 – 155
Section	VI.	Bill of Quantities and Summary of Packages	156 – 142
Section	VII.	Tentative List of Locations	243 – 190
Section	VIII.	Formats for Submission of Data	291 – 303
Section	IX.	Drawings	304 – 315
Section	X.	Bidding Data	316 – 319
Section	XI.	Formats for Qualification Information	320 – 322
Section	XII.	Bank Guarantee Form for EMD	323 – 324
Section	XIII.	Bank Guarantee Form for Performance Security and Mobilisation Advance	325 – 328
Section	XIV.	Tender Acceptance Form and Integrity Pact	329 – 336
Section	XV.	Instructions for Online Submission of Tenders	337 – 340
Section	XVI.	Safety Code	341 – 350
Section	XVII.	Model Rules for the Protection of Health and Sanitary Arrangements for Workers	351 – 357
Section	XVIII.	Contractor's Labour Regulations	358 – 364
Section	XIX.	Checklist	365 – 371
Section	XX.	Contract form	372 - 373

SECTION- I

NOTICE INVITING TENDERS (NIT)

Government of India
 Ministry of Water Resources, River Development and Ganga Rejuvenation
Bhujal Bhawan, NH-IV, Central Ground Water Board,
 Faridabad, Pin - 121001
 Phone:0129247721
 Email: seop-cgwb@nic.in

e-Tender Inquiry No. NIET No. 12/2022-23/MMS-I

**NOTICE INVITING TENDERS
 (National Competitive Bidding)**

- 1 For and on behalf of President of India, The Chairman, Central Ground Water Board, invites online bid under two-bid system (technical bid and financial bid) at CPP portal <http://eprocure.gov.in/eprocure/app> from eligible and qualified bidders for Construction of PIEZOMETERS (810 Nos) in SOFT ROCK/HARD Rock and Supply, Installation, Commissioning of DWLRs and telemetry, Establishment of Data Acquisition system & its maintenance for Real Time Ground Water Level monitoring and supply of Ground water level, ground water temperature data from site and receipt of data at National Data Centre, CHQ, Faridabad, in a desired format from 810 Nos CONSTRUCTED Piezometers wells Through telemetry systems with 05 years warranty and 02 years AMC in STATES of UTTAR PRADESH, BIHAR, JHARKHAND, WEST BENGAL and ODISHA.

2

Tender ID	Name of Package	Region	Estimated Cost in INR (Excluding GST)	Estimated Cost of PART-A of the Tender i.e., for construction of PZ in INR (Excluding GST)	EMD in INR(2% of Total Estimated Cost (Excluding GST))
	Package 6	UTTAR PRADESH, BIHAR, JHARKHAND, WEST BENGAL and ODISHA	66,84,70,500/-	52,46,60,500/-	1,33,69,410/-

Critical Dates		Date	Time
1	Dates of Online Publication of Tender Documents in CPP portal		
2	Dates of Tender Document Download	Start	
3		End	
4	Deadline for seeking further information/ clarifications through email		
5	Date of Pre-Bid Meeting		
6	Dates of Online Submission of	Start	

7	Tender	End		
8	Deadline for Physical Submission of Cost of Tender Documents and EMD/ Bid Security			
9	Time and Date for Opening of Technical Bid			
10	Time and Date for Opening of Financial Bid		Will be communicated online after technical evaluation	

- 3 Interested tenderer may obtain further information about these requirements from the above office during working hours or through email and/or from the websites <http://cgwb.gov.in> and <https://eprocure.gov.in/eprocure/app>
- 4 Tender documents may be downloaded from the above websites. The bidders must pay non-refundable fee of Rs.5000/- (Five Thousand) only in the form of Account Payee Demand Draft from any of the commercial bank in India, in favour of Drawing & Disbursing Officer, Central Ground Water Board, payable at Faridabad on or before the deadline fixed.
- 5 All tenders must be accompanied with EMD/ Bid Security as mentioned in Para 2 in favour of The Drawing & Disbursing Officer, Bhujal Bhawan, NH-IV, Central Ground Water Board, payable at Faridabad, in the manner prescribed in bidding documents, on or before the deadline fixed.
- 6 In the event of any of the above mentioned tender opening date being declared as a holiday/ closed day or the purchase organization, the tenders will be opened on the next working day at the appointed time.
- 7 Bids shall be received online only at the website of CPP portal <https://eprocure.gov.in/eprocure/app>.
- 8 Aspiring bidders who have not enrolled/ registered in CPP portal are advised to enrol/ register before participating through the portal. The portal enrolment is free of cost. The bidders are advised to go through the instructions provided at section-XV: 'Instructions for online bid submission'.
- 9 The bidders will be at liberty to be present either in person or through an authorised representative, who must carry 'Bid Acknowledgement Receipt', at the time of opening of bid or can view the bid opening event online at their remote end.
- 10 **This Tender can be Cancelled/Withdrawn any time without assigning any reasons to bidders/ tenderers**

 Superintending Engineer
 Bhujal Bhawan, NH-IV,
 Central Ground Water Board,
 Faridabad, Pin - 121001

SECTION- II
INSTRUCTIONS TO BIDDERS
(ITB)

	<u>SECTION- II</u>
	INSTRUCTIONS TO BIDDERS (ITB)
1.	General
	The Employer wishes to receive bids for the Construction of Piezometers in Soft Rock/ Hard Rock and Supply, Installation, Commissioning of DWLRs and telemetry, Establishment of Data Acquisition system & its maintenance for Real Time Ground Water Level monitoring and supply of Ground water level, ground water temperature data from site and receipt of data at National Data Centre, CHQ, Faridabad, in a desired format from 810 Nos CONSTRUCTED Piezometers wells Through telemetry systems with 05 years warranty and 02 years AMC in STATES of UTTAR PRADESH, BIHAR, JHARKHAND, WEST BENGAL and ODISHA. Throughout these bidding documents, the terms bid and tender and their derivatives (bidder/tenderer, bid/tendered, bidding/tendering, etc.) are synonymous..
1.1	The Employer has issued these tender enquiry documents for the Construction Of Piezometers in Soft Rock/ Hard Rock and Supply, Installation, Commissioning of DWLRs and telemetry, Establishment of Data Acquisition system & its maintenance for Real Time Ground Water Level monitoring and supply of Ground water level, ground water temperature data from site and receipt of data at National Data Centre, CHQ, Faridabad, in a desired format from 810 Nos CONSTRUCTED Piezometers wells Through telemetry systems with 05 years warranty and 02 years AMC in STATES of UTTAR PRADESH, BIHAR, JHARKHAND, WEST BENGAL and ODISHA. and related services as mentioned in Section–V: “Scope of Work and Technical Specifications”, which also indicates, <i>interalia</i> , the Tentative List of Locations.
1.2	This section (Section II: “Instructions to Bidders”) provides the relevant information as well as instructions to assist the prospective tenderers in preparation and submission of tenders. It also includes the mode and procedure to be adopted by the Employer for receipt and opening as well as scrutiny and evaluation of tenders and subsequent placement of contract.
1.3	Before formulating the tender and submitting the same to the Employer, the tenderer should read and examine all the terms, conditions, instructions etc. contained in the tender documents. Failure to provide and/ or comply with the required information, instructions incorporated in these tender documents may result in rejection of its tender.
2	Eligibility Criteria of Bidder
2.1	This invitation to bid is open to any bidder meeting the following requirements : (a) The bidder shall be qualified for the contract as notified by the Employer in subsequent clauses.

2.2	<p>(a) Any tenderer, (proprietorship firms, partnerships firms, companies, corporations, joint ventures) registered with Central or State Government or the Central Ground Water Authority (CGWA) are eligible to participate in the tender. A self attested copy in respect of valid registration/ enlistment with the respective authorities is to be submitted</p> <p>(b) Bidders are permitted to form consortium. The clauses as given below shall be applicable for consortium.</p> <ol style="list-style-type: none"> i. In case of a consortium /Joint Venture, certified copy of the agreement between various partners shall be submitted with the tender. ii. The consortium /Joint Venture shall nominate a Representative who shall have the authority to conduct all business for and on behalf of any and all the members of the JV during the bidding process and, in the event the JV is awarded the Contract, during contract execution. iii. The consortium /Joint Venture will identify a lead partner who will be authorised to execute the contract with the department. All financial transactions and liabilities shall rest with the lead partner. . iv. JV members are jointly and severally responsible and liable for the contract. For pre- qualification, the JV should fulfil the criteria specified in the pre-qualification document. The attributes to be evaluated will be the same as for individual contractors; however, certain parameters up to the specified limits have to be essentially met by them collectively, some by the lead partner, and some by the other partner, as briefly described below: <ul style="list-style-type: none"> X. Qualifying factors to be met collectively: <ul style="list-style-type: none"> (A) Annual turnover; (B) Nos. of Well construction experience Y. Qualifying factors for lead partner: <ul style="list-style-type: none"> (A) <i>Nos. of Well construction experience/Nos. of DWLR supplied experience Not less than of 50 (fifty) percent of the respective limits of above criteria prescribed in case of individual contractors may be accepted;</i> Z. Qualifying factors for other partner: <ul style="list-style-type: none"> Same as for lead partner except that for the factors specified in (Y) above, a lower limit of 25 (twenty-five) per cent. <p>v. A tenderer shall submit only one bid in the same tendering process, either individually as a tenderer or as a partner of a consortium /Joint Venture.</p> <p>vi. Number of the members/firms in a joint venture shall not be more than five including the lead partner</p> <p>(c) A Bidder shall not have a conflict of interest. Any Bidder found to have a conflict of interest shall be disqualified. A Bidder may be considered to have a conflict of interest for the purpose of this bidding process, if the Bidder:</p> <ol style="list-style-type: none"> i. directly or indirectly controls, is controlled by or is under common control with another Bidder or ii. receives or has received any direct or indirect subsidy from any other Bidder;or iii. has the same legal representative as another Bidder; or iv. has a relationship with another Bidder, directly or through common third parties,
------------	---

	<p>that puts it in a position to influence the bid of another Bidder, or influence the decisions of the Purchaser regarding this bidding process; or</p> <p>v. participates in more than one bid in this bidding process. Participation by a Bidder in more than one Bid will result in the disqualification of all Bids in which such Bidder is involved.</p>
	<p>(d) <i>All the Bidder should specify their DWLR OEM/Suppliers (Number of such DWLR OEM/authorized Suppliers should not more than 3) and give a undertaking that they will supply DWLR from those reputed DWLR OEM/Authorized Suppliers only and clearly mentioning the numbers of DWLR to be supplied by each OEM/authorized Suppliers as per specifications of DWLRs mentioned in the Tender Document</i></p> <p>(e) Bidders will be required to employ at least one ground water professional with minimum qualification of graduate degree in engineering/master's degree in geosciences with minimum 3 years of experience in construction of exploratory & observation, Piezometer wells and similar works. The undertaking for employment of these ground water professional be given.</p> <p>(f) Bidder will be required to deploy at least one dedicated Service Engineer cum operator at the Regional office Data Center for Operation of DWLR system and ensure seamless data transfer from remote DWLR stations to National data Center through GSM/GPRS network & then to India WRIS/WIMS software through internet. The processed data from India WRIS/ WIMS in the form of reports/ bulletins will be transmitted to Regional & National Data Centre as per technical specifications. The undertaking for employment of these ground water professional be given.</p> <p>(g) Bidders will be required to deploy at least 40 rigs for the package along with submersible pumps of various capacities, ancillaries equipments tools accessories required for construction of well and pumping test as mentioned in the section V, Scope of Work and Technical specification. An undertaking in this regard should be submitted in the technical Bid.</p> <p>(h) Deleted</p> <p>(i) Bid Capacity</p> <p>The bidder should possess the bidding capacity as calculated by the specified formula. The formula generally used is:</p> <p>Available bid capacity = A x 1.5 x N -B, where</p> <p>A = Maximum value of engineering (Civil/ Electrical/ Mechanical as relevant to work being procured) works executed in any one year during the last five years (updated at the current price level), taking into account the completed as well as works in progress.</p> <p>N = Number of years prescribed for completion of the work in question.</p> <p>B = Value (updated at the current price level) of the existing commitments and ongoing works to be completed in the next 'N' years.</p>
<p>2.3</p>	<p>Average annual financial turnover during the last three years, ending 31st March of the previous financial year should be at least 30% of the estimated cost. (Balance Sheet duly audited and certified by Chartered Accountant)</p> <p>Note: Note: In case of last financial year Bidder may submit the Provisional Balance sheet duly signed by CA.</p>

<p>2.4</p>	<p><i>The bidder should have experience of having successfully completed similar works during last 7 years ending last day of month previous to the one in which tenders are invited:</i></p> <p>(a) <i>Three similar completed works costing not less than the amount equal to 40% of the (estimated cost of PART-A of the Tender i.e for construction PZ part if similar work is Type-1 nature) or (estimated cost of PART-B of the Tender i.e for the DWLR part if similar work is Type-2 nature)</i></p> <p style="text-align: center;"><i>or</i></p> <p><i>Two similar completed works costing not less than the amount equal to 50% of (estimated cost of PART-A of the Tender i.e for construction PZ part if similar work is Type-1 nature) or (estimated cost of PART-B of the Tender i.e for the DWLR part if similar work is Type-2 nature)</i></p> <p style="text-align: center;"><i>or</i></p> <p><i>One similar completed work costing not less than the amount equal to 80% of the (estimated cost of PART-A of the Tender i.e for construction PZ part if similar work is Type-1 nature) or (estimated cost of PART-B of the Tender i.e for the DWLR part if similar work is Type-2 nature)</i></p> <p style="text-align: center;"><i>or</i></p> <p><i>Sum total of similar completed works costing not less than the amount equal to 100% of the (estimated cost of PART-A of the Tender i.e for construction PZ part if similar work is Type-1 nature) or (estimated cost of PART-B of the Tender i.e for the DWLR part if similar work is Type-2 nature) in a single financial year.</i></p> <p>(b) Definition of Similar works:</p> <p><i>Types of Similar works are defined as:</i></p> <p><i>Type-1: Any work in which drilling for exploration/exploitation of natural resources is component of scope of work</i></p> <p><i>Type-2:Supply/ Installation/commissioning/Maintenance of Digital Water Level Recorder.</i></p>
	<p>(c) The value of the executed work shall be brought to the current costing level by enhancing the actual value of works at simple rate of 7% per annum calculated from the date of completion to last date of submission of bid.</p> <p>(d) The tenderer shall submit details of works executed by them in last 7 years for qualification of work experiences criteria, documentary proof such as completion certificate & other documents from client clearly indicating the nature/scope of work, contract number, contract amount and actual date of completion, of such works. Rig deployment /copy of work order cannot be considered as work completion. Work completion certificate or part completion certificate is to be submitted.</p> <p>(e) In case the work is done for private/ Government clients, details as per table at In case the work is done for private/ Government clients, details as per table at SI.No.3 (a) & 3 (b) of Section XI are to be submitted. Documents are to be submitted. Documents establishing receipt of payment for such works are to be submitted. For this purpose TDS certificate or Form 26 AS of Income Tax department or copy of Bank statement or any other document clearly indicating name of organisation making payment, amount of payment shall be submitted.</p> <p>(f) The tenderer or their DWLR OEM/authorized Suppliers as specified in ITB Clause 2.2 (d)</p>

	<p>should have supplied and commissioned at least 20 % of the Digital Water Level Recorders stations with GSM / GPRS based telemetry during previous 7 (Seven) Financial years to Central Government/ State Government Departments or Public Sector Undertakings or any Project/ any other Public/ Private Customers in India.</p> <p>Note: The proof of supply as per supply order along with Commissioning/ Installation / Performance report/certificate in respect of successful commissioning</p> <p>(g) The bidder should have after sales support in the region (within a radius of 500 km from the State Capital) for Digital Water Level Recorders stations with GSM / GPRS based telemetry. If bidder does not have any after sales support office within 500 km from state Capital at the time of bidding, he shall be required to establish the same within one month after successful award of contract.</p> <p>(h) The bidder shall submit the product brochure/literature, compliance statement duly signed by the bidder and other supporting document if any to establish the claim that the offered equipment meets the technical specifications provided in tender document. If there is any deviation in specification it should be mentioned in separate column of compliance statement</p>
2.5	The bidder must submit an undertaking for carrying out chemical analysis of water samples from any NABL accredited lab/labs. The Lab/labs shall have combined capacity of analyzing at least 300 water samples in a month.
2.6	<p>Well construction Experience</p> <p><i>They must have drilled/completed wells to a depth of at least 200 m. Number of such wells should not be less than 20% of number of wells to be constructed in the Tender during previous 7 (Seven) Financial years for Central Government/ State Government Departments or Public Sector Undertakings or any Project/ any other Public/ Private Customers in India.</i></p>
2.7	<p>After approval of Technical bid, the Financial bid will be opened only after qualifying the Technical Bid. The Financial bid will be evaluated considering the Gross total amount of BOQ including GST. Note: 1. The bidders are requested to quote the rate (excluding GST) against the item in BOQ (Financial bid). The tax (GST) is taken during uploading of the tender document in CPPP is 18%. This helps in uniform comparison of bids. The actual Tax (GST) as applicable will be reimbursed only after producing the following proof of tax amount paid to Government (i) A copy of GSTR-1, (ii) A copy of GSTR- 3B, (iii) CA certificate indicating details of invoices against which the payment under GSTR-3B has been made and any other relevant document.</p>
2.8	Deleted

- 2.9** Tenderers are required to submit **duly self attested** following documents:-
- (a) Copy of valid registration/ enlistment with the respective authorities (Reference: clause 2.2 of eligibility criteria). **(Sl.No.1 of Section XI)**
 - (b) In case of a consortium, certified copy of the agreement between various partners. (Reference : Clause 2.2 of eligibility criteria)
 - (c) Scanned copy of undertaking of having employed the ground water professional during execution of work. (Reference : Clause 2.2 (c) of eligibility criteria)
 - (d) Scanned copy of Undertaking as per eligibility criteria 2.2 (d).
 - (e) Current Available Bid Capacity of Bidder duly certified by CA (as per clause 2.2 (i)) with documentary proof of “A value i.e. Maximum value of engineering works executed during any last five year” and “B value i.e. value of existing commitments and ongoing works to be completed in the next “N” years.”
 - (f) Details of works completed as per table at **Sl. No.3 (a) of Section XI along with documentary proof.**(Reference : Clause 2.4 of eligibility criteria)
 - (g) Details of payment received for completed works alongwith documentary proofas per table at Sl. No 3(B) of Section XI (Reference : Clause 2.4 of eligibility criteria)
 - (h) Scanned copy of undertaking as per eligibility criteria 2.5
 - (i) Details of Borewells/ Tubewells constructed as per table at **Sl. No.4 of Section XI.**(Reference : Clause 2.6 of eligibility criteria)
 - (j) Scanned copy of EMD: As per clause 13 of Section II Instructions to Bidders.
 - (k) Scanned copy of tender fee
 - (l) Scanned copy of Tender Acceptance letter: As per format in Section XIV
 - (m) Undertaking as per clause2.5 of eligibility criteria
 - (n) The proof of supply in respect of DWLR and telemetry as per supply order along with delivery challan and Commissioning report/ Installation report/ Performance certificate in respect of successful commissioning.(Reference : Clause 2.4 of eligibility criteria) along with documentary proof.
 - (o) Certificate for After Sales support certificate. (Reference: Clause 2.4 of eligibility criteria) along with documentary proof in respect of DWLR and telemetry.
 - (p) Details fo DWLR's supplied installed and commissioned alongwith undertaking for no adverse report for atleast 1 year
 - (q) The product brochure/literature, compliance statement duly signed by the bidder and other supporting document if any to establish the claim that the offered equipment meets the technical specifications provided in tender document. (Reference: Clause 2.4 (h) of eligibility criteria).
 - (r) A clause-by-clause commentary on the Purchaser's technical specifications demonstrating substantial responsiveness of the Goods and Services to those specifications or a statement of deviations and exceptions to the provisions of the Technical Specifications. For purposes of the commentary to be furnished above, the Bidder shall note that standards for workmanship, material and goods, and references to brand names or catalogue numbers designated by the Purchaser in its Technical Specifications are intended to be descriptive only and not restrictive. The Bidder may substitute alternative standards, brand names and/or catalogue numbers in its bid, provided that it demonstrates to the Purchaser's satisfaction that the substitutions ensure substantial equivalence to those designated in the Technical Specification along with the certificates/ documents as specified in the Scope of Work and Technical Specifications Part C, para 1.0 Scope of Work (xix).
 - (s) Tender document duly signed in all pages, scan and submit online along with above.
 - (u) Duly Signed copy of Integrity Pact as per format in Section XIV.

2.10	Bidders have the option to submit the documents listed above in Clause 2.9 online only. In addition only original EMD & Tender Fee to be submitted to Superintending Engineer, Central Ground Water Board, Bhujal Bhawan, NH-IV Faridabad, Haryana 121001 on or before deadline of tender submission. Note: Documents listed above at Clause 2.9 are to be mandatorily submitted online along with the bid.
2.11	Deleted
2.12	Non-submission of any document listed in clause 2.9 & 2.10 above, will lead to rejection of the bid of the bidder.
2.13	The eligibility of the bidder shall be decided only as per Section-II Clause 2 Eligibility Criteria of Bidder (Clause 2.1 to 2.12), irrespective of whatsoever elsewhere is mentioned in the tender document.
3	Cost of Bidding Document/ Tendering Expense
3.1	The tenderer shall bear all costs and expenditure incurred and/ or to be incurred by it in connection with its tender including preparation, mailing and submission of its tender and for subsequent processing the same. The Employer will, in no case be responsible or liable for any such cost, expenditure regardless of the conduct or outcome of the tendering process.
4	One Bid per Bidder
4.1	Each bidder shall submit only one bid either by himself or as a partner in a Joint Venture.
5	Site Visit
5.1	The bidder is advised to visit and examine the site of work and its surroundings and obtain for itself on its own responsibility all information that may be necessary for preparing the Bid and entering into a contract for construction of the wells. The costs of visiting the site shall be at the bidder's own expense.
6	Contents of Bidding Documents

<p>6.1</p>	<p>In addition to Section I: “Notice inviting Tender” (NIT) the tender enquiry documents include:</p> <p>Section II: Instructions to Bidders (ITB)</p> <p>Section III: General Conditions of Contract (GCC)</p> <p>Section IV: Special Conditions of Contract (SCC)</p> <p>Section V: Scope of Work and Technical Specifications</p> <p>Section VI: Tentative List of Locations</p> <p>Section VII: Bill of Quantities and Summary of Packages</p> <p>Section VIII: Formats for Submission of Data</p> <p>Section IX: Drawings</p> <p>Section X: Bidding Data</p> <p>Section XI: Formats for Qualification Information</p> <p>Section XII: Bank Guarantee Form for EMD</p> <p>Section XIII: Bank Guarantee Form for Performance Security</p> <p>Section XIV: Tender Acceptance Form</p> <p>Section XV: Instructions for Online Submission of Tenders</p> <p>Section XVI: Safety Code</p> <p>Section XVII: Model Rules for the Protection of Health and Sanitary Arrangement for Workers</p> <p>Section XVIII: Contractor’s Labour Regulations</p> <p>Section XIX: Checklist.</p> <p>Section XX: Contract form.</p>
<p>7</p>	<p>Pre-Bid Meeting and Clarification of Bidding Documents</p>
<p>7.1</p>	<p>The bidder or his official representative is invited to attend a pre-bid meeting which will take place at Central Ground Water Board, Bhujal Bhawan, NH-IV Faridabad, Haryana 121001 on _____ at _____ hours.</p>
<p>7.2</p>	<p>The purpose of the meeting will be to clarify issues and to answer questions on any matter that may be raised at that stage.</p>
<p>7.3</p>	<p>The bidder is requested to submit any questions in writing/ FAX/e-mail to reach the Employer not later than <u>“Deadline for seeking further information/ clarifications through email”</u>.</p>
<p>7.4</p>	<p>Any modification of the bidding documents listed in Clause 6.1 which may become necessary as a result of the pre-bid meeting shall be made by the Employer exclusively through the issue of an Addendum/ Corrigendum and the same will be available in the web site and not through the minutes of the pre-bid meeting.</p>
<p>7.5</p>	<p>A tenderer requiring any clarification or elucidation on any issue of the tender enquiry documents may take up the same with the Employer in writing or by fax/ e-mail provided that such request is received by the critical date mentioned in Para 2 of Section I (Notice Inviting Tenders). The Employer will publish the response to such queries on CPP portal prior to the prescribed date of submission of tender.</p>

7.6	To assist in the examination, evaluation and comparison of bids, the Employer may at its discretion, ask any bidder for clarification of its bid, including breakdown of unit, rate. The request for clarification and the response shall be in writing, but no change in the price or substance of the bid shall be sought or offered or permitted.
8	Amendments to Bidding Documents
8.1	At any time prior to the deadline for submission of tenders, the Employer may, for any reason deemed fit by it, modify the tender enquiry documents by issuing suitable amendment(s) to it.
8.2	Such an amendment will be notified through website https://eprocure.gov.in/eprocure/app and will be binding on them. The tenderers are advised to visit this website from time to time till the bid submission end date and take note of amendment(s) before uploading their tender.
8.3	In order to provide reasonable time to the prospective tenderers to take necessary action in preparing their tenders as per the amendment, the Employer may, at its discretion extend the deadline for the submission of tenders and other allied time frames, which are linked with that deadline.
9	Language of the Bid
9.1	The tender submitted by the tenderer and all subsequent correspondence and documents relating to the tender exchanged between the tenderer and the Employer, shall be written in the English language.
9.2	The tender submitted by the tenderer and all subsequent correspondence and documents relating to the tender exchanged between the tenderer and the Employer, may also be written in the Hindi language, provided that the same are accompanied by English translation, in which case, for purpose of interpretation of the tender, the English translations shall prevail.
10	Bid Prices
10.1	Unless stated otherwise in the bidding document, the contract shall be for the whole Work based on the unit rates and prices in the Bill of Quantities submitted by the bidder. The bidder shall fill in rates for all items of the Work described in the Bill of Quantities in financial bid. The rate filled in BOQ against the item wise should be exclusive of tax (GST). Note: Bidders are requested not to fill any rates in the technical bid section otherwise the bid will summarily be rejected.
10.2	Prices payable to the Contractor as stated in the contract are firm and not subject to adjustment during the performance of the contract. Prices quoted in rate should be cost per unit against each item in BOQ without GST. The actual Tax GST amount as applicable shall be reimbursed to the contractor only after producing the following proof of tax amount paid to Government (i) A copy of GSTR-1, (ii) A copy of GSTR- 3B, (iii) CA certificate indicating details of invoices against which the payment under GSTR-3B has been made and any other relevant document.
11	Currency of Bid and Payment
11.1	The tenderer shall quote only in Indian Rupees.

12	Bid Validity
12.1	If not mentioned otherwise in the ITB, the tenders shall remain valid for acceptance for a period of 120 days (one hundred and twenty days) after the date of tender opening prescribed in the tender document. In case the last date of submission of bid has been extended, 120 days shall be counted from extended date. Any tender valid for a shorter period shall be treated as unresponsive and rejected.
12.2	If any tenderer withdraws his tender before the said period, then the Employer shall, without prejudice to any other right or remedy, be at liberty to forfeit the said Earnest Money.
12.3	In exceptional cases, the tenderers may be requested by the Employer to extend the validity of their tenders up to a specified period. Such request(s) and responses thereto shall be conveyed by post or by fax/ email followed by post. The tenderers, who agree to extend the tender validity, are to extend the same without any change or modification of their original tender and they are also to extend the validity period of the EMD accordingly. A tenderer, however, may not agree to extend its tender validity without forfeiting its EMD.
12.4	In case the day up to which the tenders are to remain valid falls on/ subsequently declared a holiday or closed day for the Employer, the tender validity shall automatically be extended up to the next working day.
13	Bid Security/ Earnest Money Deposit (EMD)
13.1	Pursuant to ITB clauses 6.1 the tenderer shall furnish along with its tender, earnest money for amount as shown in the NIT. The earnest money is required to protect the Employer against the risk of the tenderers unwarranted conduct as amplified under sub-clause 13.7 below.
13.2	The earnest money shall be denominated in Indian Rupees.
13.3	The earnest money shall be furnished in one of the following forms: (a) Account Payee Demand Draft (b) Fixed Deposit Receipt (c) Bank Guarantee The demand draft, fixed deposit receipt shall be drawn on any commercial bank in India, in favour of the authority specified in the Para 5 of NIT. In case of bank guarantee, the same is to be provided from any commercial bank in India as per the format specified under Section XII in these documents.
13.5	The earnest money shall be valid for a period of 60 (sixty) days beyond the validity period of the tender.
13.6	Unsuccessful tenderers' earnest money will be returned to them without any interest, after expiry of the tender validity period, but not later than 30 days after conclusion of the resultant contract. Successful tenderers earnest money will be returned without any interest, after receipt of performance security from that tenderer.
13.7	Earnest money of a tenderer will be forfeited, if the tenderer withdraws or amends its tender or impairs or derogates from the tender in any respect, withdraws its tender, or fails to sign the contract within the period of validity of its tender. The successful tenderers earnest money will be forfeited if it fails to furnish the required performance security within the specified period.
14	Bid Submission

14.1	Tenders shall be received online only at the website of CPP portal http://eprocure.gov.in/eprocure/app . All the scanned copies of documents comprising the bid shall be serially numbered and mentioned in the checklist provided in section XIX which should be the first document of the bid.
14.2	Deleted
14.3	The tenderer, after submitting its tender, is permitted to alter/ modify its tender within the deadline for submission of tender through online only.
14.4	No tender should be withdrawn after the deadline for submission of tender and before expiry of the tender validity period. If a tenderer withdraws the tender during this period, it will result in forfeiture of the earnest money furnished by the tenderer in its tender.
14.5	<p><u>Documents Comprising the Tender</u></p> <p>The tender to be submitted by tenderer shall contain the following documents, duly filled in, as required:</p> <p>Cover 1 (Technical Bid)</p> <p>(a) Scanned copy of Tender Fee and EMD</p> <p>(b) Documentary evidence, as necessary in terms of clauses 2 and 16.3 establishing that the tenderer is eligible to submit the tender and, also, qualified to perform the contract if its tender is accepted.</p> <p>(c) Tender Acceptance Letter</p> <p>(d) Scanned copy of GST Registration/ TIN/ TAN/ PAN</p> <p>(e) Mandate form as per prescribed format for electronic clearing service.</p> <p>Cover 2</p> <p>(a) Financial Bid.</p> <p>Note: (1) Only rates without GST against each item in BOQ shall be filled up. The GST @ 18% taken at the time of tender publishing in CPPP.</p> <p>(2) All BOQs will be evaluated put together as a single package. The bids will be summarily rejected if the bidder does not quote for all the BOQ's of the Package. If the bidder does not quote rate for any item of the BOQ, it will be deemed to be covered under the total cost of the BOQ.</p>
14.6	A tender, which does not fulfil any of the above requirements and/ or gives evasive information/ reply against any such requirement, shall be liable to be ignored and rejected.
14.7	The tender shall either be typed or written in indelible ink and the same shall be signed by the tenderer or by a person(s) who has been duly authorized to bind the tenderer to the contract. The letter of authorization shall be by a written power of attorney, which shall also be furnished along with the tender.
14.8	The tender shall be duly signed at the appropriate places as indicated in the tender documents and all other pages of the tender including printed literature, if any shall be initialled by the same person(s) signing the tender. The tender shall not contain any erasure or overwriting, except as necessary to correct any error made by the tenderer and, if there is any such correction; the same shall be initialled by the person(s) signing the tender.
15	Bid Opening
15.1	The Employer will open the tenders at the specified date and time and at the specified place as indicated in the Para 2 of NIT (Section I). In case the specified date of tender opening falls on/ is subsequently declared a holiday or closed

	day for the Employer, the tenders will be opened at the appointed time and place on the next working day.
15.2	<p>The bidders will be at liberty to be present either in person or through an authorised representative, who must carry 'Bid Acknowledgement Receipt', at the time of opening of bid or can view the bid opening event online at their remote end.</p> <p>The tender opening official(s) will prepare a list of the representatives attending the tender opening. The list will contain the representatives' names and signatures and corresponding tenderers' names and addresses.</p>
15.3	<p>The technical bids through online in CPPP shall be opened in the first stage, at the prescribed time and date. These bids shall be scrutinized and evaluated by the competent committee/ authority with reference to parameters prescribed in the tender document. Thereafter, in the second stage, the financial bids of only the technically acceptable offers (as decided in the first stage) shall be opened for further scrutiny and evaluation.</p> <p>Note: No bidders shall write the amount in anywhere in technical bid. If so the bid will be treated as non responsive and rejected such bids.</p>
16	Examination of Bids and Determination of Responsiveness
16.1	<p><u>Scrutiny and Evaluation of Tenders</u></p> <p>Tenders will be evaluated on the basis of the terms and conditions already incorporated in the tender enquiry document, based on which tenders have been received and the terms, conditions mentioned by the tenderers in their tenders. No new condition will be brought in while scrutinizing and evaluating the tenders.</p>
16.2	<p><u>Preliminary Scrutiny of Tenders</u></p> <p>The tenders will first be scrutinized to determine whether they are complete and meet the essential and important requirements, conditions as prescribed in the tender enquiry document. The tenders that do not meet the basic requirements are liable to be treated as unresponsive and ignored.</p> <p>The following are some of the important aspects, for which a tender may be declared unresponsive and ignored:</p> <ol style="list-style-type: none"> (a) Tender is unsigned. (b) Tenderer is not eligible. (c) Tender validity is shorter than the required period. (d) Required Tender Fee and EMD have not been provided. (e) Tenderer has not agreed to give the required performance security. (f) Tenderer has not agreed to essential condition(s) specially incorporated in the tender enquiry.

16.3	<p><u>Documents Establishing Tenderer's Eligibility and Qualifications</u> The documentary evidence needed to establish the tenderer's qualifications shall fulfil the following requirements:</p> <p>(a) Self attested copy in respect of valid registration/ enlistment with relevant authorities as mentioned in clause 2.2.</p> <p>(b) Audited Balance Sheet of last three financial years</p> <p>(c) Self attested copy of 'Acceptance of Tender'/ 'Notice of Award'/ 'Contract' of similar works, as defined in clause 2.4, during the last seven years (ending on the last day of the month previous to the one in which the tenders are invited) and 'Work Completion Certificate' from the Employer for those works/ documents establishing receipt of payment for such works.</p> <p>(d) List of wells constructed by the contractor where depth of well is 200 m or more with supporting documents in the format prescribed in Section XI(4).</p> <p>(e) All the documents as mentioned in the clause 2.9</p>
16.4	<p><u>Tenderers Capability to Perform the Contract</u> The Employer, through the above process of tender scrutiny and tender evaluation will determine to its satisfaction whether the tenderer, whose tender has been determined as the lowest evaluated responsive tender is eligible, qualified and capable in all respects to perform the contract satisfactorily.</p>
16.5	<p>The above mentioned determination wills, interalia, take into account the tenderers financial, technical and execution capabilities for satisfying all the requirements of the Employer as incorporated in the tender document. Such determination will be based upon scrutiny and examination of all relevant data and details submitted by the tenderer in its tender as well as such other allied information as deemed appropriate by the Employer.</p>
16.6	<p><u>Contacting the Employer</u> From the time of submission of tender to the time of awarding the contract, if a tenderer needs to contact the Employer for any reason relating to this tender enquiry and/ or its tender, it should do so only in writing.</p>
16.7	<p>In case a tenderer attempts to influence the Employer in the Employer's decision on scrutiny, comparison and evaluation of tenders and awarding the contract, the tender of the tenderer shall be liable for rejection in addition to appropriate administrative actions being taken against that tenderer, as deemed fit by the Employer.</p>
17	<p>Award Criteria</p>
17.1	<p>Subject to ITB clause 17.2, the contract will be awarded to the lowest evaluated responsive tenderer decided by the Employer. All BOQs will be evaluated put together as a single package. The bids will be summarily rejected if the bidder does not quote for all the BOQ's of the Package. If the bidder does not quote rate for any item of the BOQ, it will be deemed to be covered under the total cost of the BOQ's.</p>
17.2	<p><u>Employer's Right to Accept Any Tender and to Reject Any or All Tenders</u> The Employer reserves the right to accept in part or in full any tender or reject any tender without assigning any reason or to cancel the tendering process and reject all tenders at any time prior to award of contract i.e. signing of contract, without incurring any liability, whatsoever to the affected tenderer or tenderers.</p>

17.3	<u>Variation of Quantities at the Time of Award and during the execution of work</u> At the time of awarding of contract and during the execution of work, the Employer reserves the right to increase or decrease, the quantities of works maximum up to 20% without any change in the unit price and other terms and conditions quoted by the tenderer.
18	Notification of Award and Signing of Agreement
18.1	Before expiry of the tender validity period, the Employer will notify the successful tenderer(s) in writing, by registered/ speed post or by email/ fax (to be confirmed by registered/ speed post) that its tender for works, also briefly indicating there in the essential details like description, specification and quantity of the works and related services and corresponding prices are accepted. The successful tenderer must furnish to the Employer the required performance security within 21 days from the date of issue of letter of acceptance. Relevant details about the performance security have been provided under GCC Clause 3 under Section III.
18.2	<u>Issue of Contract</u> Promptly after notification of award, the Employer will mail the contract form (as per Section XX) along with bank guarantee form in duplicate, to the successful tenderer by registered/ speed post.
18.3	Within 21 (twenty-one) days from the date of the contract notification, the successful tenderer will return the original copy of the contract, duly signed and dated, to the Employer by registered/ speed post.
18.4	<u>Non-Receipt of Performance Security and Contract by the Employer</u> Failure of the successful tenderer in providing performance security and/ or returning contract copy duly signed in terms of ITB clause 18.1, 18.2 and 18.3 above shall make the tenderer liable for forfeiture of its EMD and, also, for further actions by the Employer against it.
18.5	Failure of the successful Tenderer to furnish the performance Security shall constitute sufficient grounds for the annulment of the award and forfeiture of the Bid security, in which event the employer may make the award to the next lowest evaluated Tenderer or call for new tenders.
18.6	<u>Return of E M D</u> The earnest money of the successful tenderer and the unsuccessful tenderers shall be returned to them without any interest, whatsoever, in terms of ITB Clause 13.6.
18.7	<u>Publication of Tender Result</u> The result of technical evaluation, financial evaluation and award of contract shall be uploaded on CPP portal.
19	Dispute Resolution Mechanism
19.1	The method of dispute resolution is as indicated in the bidding document.
20	Corrupt and Fraudulent Practices

<p>20.1</p>	<p>It is expected that bidders/suppliers/contractors under this contract observe the highest standard of ethics during the procurement and execution of this contract. In pursuance of this policy, the employer</p> <p>(a) Defines for purpose of these provisions, the terms set forth below as follows:</p> <ul style="list-style-type: none"> i. 'Corrupt practice' means the offering, giving, receiving or soliciting of any thing of value to influence the action of a public official in the procurement process or in contract execution, and ii. 'Fraudulent practice' means a misrepresentation of facts in order to influence a procurement process or the execution of a contract to the detriment of the employer, and includes collusive practice among Bidders (prior to or after bid submission) designed to establish bid process at artificial non-competition levels and to deprive the employer of the benefits of free and open competition. <p>(b) Will reject a proposal for award of work if he determines that the bidder recommended for award has engaged in corrupt or fraudulent practices in competing for contract in question. Bidders shall be aware of the provision stated in clause 4.3 of the general condition of the contract.</p>
<p>21</p>	<p>This Tender can be Cancelled/Withdrawn any time without assigning any reasons to bidders/ tenderers</p>

SECTION- III

GENERAL CONDITIONS OF CONTRACT (GCC)

	SECTION- III
	GENERAL CONDITIONS OF CONTRACT
1	Definition and Interpretation
1.1	<p>Definition</p> <p>In this Contract, unless the context requires otherwise, the following terms shall have the meaning ascribed to them hereunder:</p> <p>(i) Works or work means the works by or by virtue of the contract contracted to be executed whether temporary or permanent, and whether original, altered, substituted or additional.</p> <p>(ii) Site means the land/or other places on, into or through which work is to be executed under the contract or any adjacent land, path or street through which work is to be executed under the contract or any adjacent land, path or street which may be allotted or used for the purpose of carrying out the contract.</p> <p>(iii) The Contractor means the individual, firm or company, whether incorporated or not, undertaking the works and includes the legal representative of such individual, or the successors of such firm or company and the permitted assignees of such individual, firm or company.</p> <p>(iv) The expression President, Government or Government of India means the President of India and his successors in office.</p> <p>(v) The contract agreement is being carried out through the Chairman, CGWB on behalf of the President of India,.</p> <p>(vi) The Employer means Superintending Engineer, CGWB acting on behalf of the Chairman, CGWB</p> <p>(vii) The Engineer in charge who is a representative of the Executive Engineer, concerned Division, CGWB shall supervise the work.</p> <p>(viii) Accepting Authority means the authority mentioned in Bidding Data.</p> <p>(ix) Accepted Risks are risks due to riots (other than those on account of contractor's employees), war (whether declared or not) invasion, act of foreign enemies, hostilities, civil war, rebellion, revolution, insurrection, military or usurped power, any acts of Government, damage from aircraft, acts of God such as earthquake, lightning and unprecedented floods, and other causes over which the contractor has no control and accepted as such by the Accepting Authority or causes solely due to use or occupation by Government of the part of the works in respect of which a certificate of completion has been issued or a cause solely due to Employer's faulty design of works.</p> <p>(x) Market Rate shall be the rate as decided by the Employer on the basis of the cost of materials and labour at the site where the work is to be executed plus the percentage mentioned in Bidding Data to cover all overheads and profits.</p> <p>(xi) Schedule(s) referred to in these conditions shall mean the relevant schedule(s) annexed to the bid papers or the standard Schedule of Rates of the Government mentioned in Bidding Data hereunder, with the amendments thereto issued up to the date of receipt of the bid.</p> <p>(xii) Bid Amount means the value of the entire work as stipulated in the letter of award.</p> <p>(xiii) Employer site representative means <i>Hydrogeologist of the Regional office & Engineer of the Divisional office, nominated by concern Regional Director of</i></p>

	<p align="center">CGWB</p> <p>(xiv) GST shall mean Goods and Service Tax - Central, State and Inter State.</p>
1.2	<p>Interpretation</p> <p>(i) The Contract means and includes the documents forming the bids and acceptance thereof and the formal agreement executed between the competent authority on behalf of the President of India and the bidders, together with the documents referred to therein including these conditions, the specifications, designs, drawings and instructions issued from time to time by the Employer and all these documents taken together, shall be deemed to form one contract and shall be complementary to one another.</p> <p>(ii) Where the context so requires, words imparting the singular only also include the plural and vice versa. Any reference to masculine gender shall whenever required include feminine gender and vice versa.</p> <p>(iii) Headings and Marginal notes to these General Conditions of Contract shall not be deemed to form part thereof or be taken into consideration in the interpretation or construction thereof or of the contract.</p> <p>(iv) The original Contract shall remain with the Employer. The contractor shall be furnished, free of cost one certified copy of the contract documents together with all drawings as may be forming part of the bidding documents except standard specifications, Schedule of Rates and similar other printed and published documents. None of these documents shall be used for any purpose other than that of this contract.</p>
1.3	<p>Discrepancies & Adjustment of Errors</p> <p>The several documents forming Contract are to be taken as mutually explanatory of one another, detailed drawings being followed in preference to small scale drawing and figured dimensions in preference to scale and special conditions in preference to General Conditions.</p> <p>In the case of discrepancy between the schedule of Quantities, the Specifications and/or the Drawings, the following order of preference shall be observed:</p> <p>(i) Description of Schedule of Quantities.</p> <p>(ii) Particular Specification and Special Condition, if any.</p> <p>(iii) Drawings.</p> <p>(iv) Technical Specifications.</p> <p>(v) Indian Standard Specifications of B.I.S.</p> <p>If there are varying or conflicting provisions made in any one document forming part of the contract, the Accepting Authority shall be the deciding authority with regard to the intention of the document and his decision shall be final and binding on the Contractor.</p> <p>Any error in description, quantity or rate in Schedule of Quantities or any omission there from shall not vitiate the Contract or release the Contractor from the execution of the whole or any part of the works comprised therein according to drawings and specifications or from any of his obligations under the contract.</p>
1.4	<p>Sufficiency of Tender</p> <p>The Contractor shall be deemed to have satisfied himself before tendering as to the correctness and sufficiency of his tender information for the works and of the rates and</p>

	prices quoted in the Schedule of Quantities, which rates and prices shall, except as otherwise provided, cover all his obligations under the Contract and all matters and things necessary for the proper completion and maintenance of the works.
1.5	<p>Signing of Contract</p> <p>The successful bidder, on acceptance of his tender by the Accepting Authority, shall, within 15 days from the stipulated date of start of the work, sign and execute the Contract consisting of:</p> <ul style="list-style-type: none"> (i) the invitation for bids, all the documents including drawings, if any, forming the tender as issued at the time of invitation of tender and acceptance thereof together with any correspondence leading thereto, and (ii) Standard Form as mentioned in Bidding Data consisting of: <ul style="list-style-type: none"> a) Various standard clauses with corrections up to the date along with annexure thereto. b) Safety Code. c) Model Rules for the protection of health, sanitary arrangements for workers employed; and d) Contractor's Labour Regulations.
1.6	<p>Works to be carried out</p> <p>The work to be carried out under the Contract shall, except as otherwise provided in these conditions, include all labour, materials, tools, plants, equipment and transport which may be required in preparation of and for and in the full and entire execution and completion of the works. The descriptions given in the Schedule of Quantities shall, unless otherwise stated, be held to include wastage on materials, carriage and cartage, carrying and return of empties, hoisting, setting, fitting and fixing in position and all other labours necessary in and for the full and entire execution and completion of the work as aforesaid in accordance with good industry practice and recognized principles.</p>
2	General Obligations
2.1	<p>Work not to be Sublet and Action in Case of Insolvency or Attempt to influence contract:</p> <p>The contract shall not be assigned or sublet without the prior written approval of the Employer. If the contractor shall assign or sublet his contract, or attempt to do so, or become insolvent or commence any insolvency proceedings or make any composition with his creditors or attempt to do so, or if any bribe, gratuity, gift, loan, perquisite, reward or advantage pecuniary or otherwise, shall either directly or indirectly, before or after the execution of the contract be given, promised or offered by the contractor, or any of his servants or agent or associate to any public officer or person in the employ of Government in any way relating to his office or employment, or if any such officer or person shall become in any way directly or indirectly interested in the contract, the Employer shall have power to adopt the course specified in Clause 8.3 hereof in the interest of Government and in the event of such course being adopted, the consequences specified in the said Clause shall ensue.</p>
2.2	<p>Changes in Contractor's organization to be approved:</p> <p>Where the contractor is a partnership firm, the previous approval in writing of the Employer shall be obtained before any change is made in the constitution of the firm. Where the Contractor is an individual or a Hindu undivided family business concern such approval as</p>

	<p>aforesaid shall likewise be obtained before the Contractor enters into any partnership agreement where-under the partnership firm would have the right to carry out the works undertaken by the Contractor. If previous approval as aforesaid is not obtained, the contract shall be deemed to have been assigned in contravention of Clause 2.1 hereof and the same action may be taken, and the same consequences shall ensue as provided in the said Clause.</p>
<p>2.3</p>	<p>Contractor to Indemnify Government Against Patent Rights:</p> <p>The Contractor shall fully indemnify and keep indemnified the Employer against any action, claim or proceeding relating to infringement or use of any patent or design or any alleged patent or design rights or Intellectual Property Rights and shall pay any royalties which may be payable in respect of any article or part thereof included in the contract. In the event of any claims made under or action brought against the Employer, in respect of any such matters as aforesaid, the contractor shall be notified thereof and the contractor shall be at liberty, at his own expense, to settle any dispute or to conduct any litigation that may arise there from, provided that the contractor shall not be liable to indemnify the Employer if the infringement of the patent or design or any alleged patent or design right is the direct result of an order passed by the Employer in this behalf.</p>
<p>2.4</p>	<p>Withholding and Lien in Respect of Sums Due from Contractor:</p> <p>(i) Whenever any claim or claims for payment of a sum of money arises out of or under the contractor against the contractor, the Employer or the Government shall be entitled to withhold and also have a lien to retain such sum or sums in whole or in part from the security, if any deposited by the contractor and for the purpose aforesaid, the Employer or the Government shall be entitled to withhold the security deposit, if any, furnished as the case may be and also have a lien over the same pending finalization or adjudication of any such claim. In the event of the security being insufficient to cover the claimed amount or amounts or if no security has been taken from the contractor, the Employer or the Government shall be entitled to withhold and have a lien to retain to the extent of such claimed amount or amounts referred to above, from any sum or sums found payable or which may at any time thereafter become payable to the contractor under the same contract or any other contract with the Employer or the Government or any contracting person through the Employer pending finalization of adjudication of any such claim.</p> <p>It is an agreed term of the contract that the sum of money or moneys so withheld or retained under the lien referred to above by the Employer or Government will be kept withheld or retained as such by the Employer or Government till the claim arising out of or under the contract is determined by the arbitrator (if the contract is governed by the arbitration clause) or by the competent court, as the case may be and that the contractor will have no claim for interest or damages whatsoever on any account in respect of such withholding or retention under the lien referred to above and duly notified as such to the contractor. For the purpose of this clause, where the contractor is a partnership firm or a limited company, the Employer or the Government shall be entitled to withhold and also have a lien to retain towards such claimed amount or amounts in whole or in part from any sum found payable to any partner/limited company as the case may be, whether in his individual capacity or otherwise.</p> <p>(ii) Government shall have the right to cause an audit and technical examination of the</p>

	<p>works and the final bills of the contractor including all supporting vouchers, abstract, etc., to be made after payment of the final bill and if as a result of such audit and technical examination any sum is found to have been overpaid in respect of any work done by the contractor under the contract or any work claimed to have been done by him under the contract and found not to have been executed, the contractor shall be liable to refund the amount of over-payment and it shall be lawful for Government to recover the same from him in the manner prescribed in sub-clause (i) of this clause or in any other manner legally permissible; and if it is found that the contractor was paid less than what was due to him under the contract in respect of any work executed by him under it, the amount of such under payment shall be duly paid by Government to the contractor, without any interest thereon whatsoever.</p> <p>Provided that the Government shall not be entitled to recover any sum overpaid, nor the contractor shall be entitled to payment of any sum paid short where such payment has been agreed upon between Employer on the one hand and the contractor on the other under any term of the contract permitting payment for work after assessment by the Employer.</p> <p>Any sum of money due and payable to the contractor (including the security deposit returnable to him) under the contract may be withheld or retained by way of lien by the Employer or the Government or any other contracting person or persons through Employer against any claim of the Employer or Government or such other person or persons in respect of payment of a sum of money arising out of or under any other contract made by the contractor with the Employer or the Government or with such other person or persons.</p> <p>It is an agreed term of the contract that the sum of money so withheld or retained under this clause by the Employer or the Government will be kept withheld or retained as such by the Employer or the Government or till his claim arising out of the same contract or any other contract is either mutually settled or determined by the arbitration clause or by the competent court, as the case may be and that the contractor shall have no claim for interest or damages whatsoever on this account or on any other ground in respect of any sum of money withheld or retained under this clause and duly notified as such to the contractor.</p>
<p>2.5</p>	<p>Levy/ Taxes Payable By The Contractor:</p> <ul style="list-style-type: none"> (i) GST, Building and other Construction Workers Welfare Cess or any other tax, levy or Cess in respect of input for or output by this contract shall be payable by the contractor and Government shall not entertain any claim whatsoever in this respect. (ii) The Contractor shall deposit royalty and obtain necessary permit for supply of the materials from local authorities. (iii) If pursuant to or under any law, notification or order any royalty, cess or the like becomes payable by the Employer and does not any time become payable by the contractor to the State Government or Local authorities in respect of any material used by the contractor in the works then in such a case, it shall be lawful to the Employer and it will have the right and be entitled to recover the amount paid in the circumstances as aforesaid from the dues of the contractor.
<p>2.6</p>	<p>Conditions for Reimbursement of Levy/ Taxes, if Levied after Receipt of Tenders</p>

	<p>All tendered rates shall be inclusive of all taxes (excluding GST) and levies payable under respective statutes.</p> <p>However, pursuant to the Constitution (46th Amendment) Act, 1982, if any further tax or levy is imposed by Statute, after the last stipulated date for the receipt of tender including extensions if any and the contractor thereupon necessarily and properly pays such taxes/levies, the contractor shall be reimbursed the amount so paid, provided such payment, if any, is not, in the opinion of the Employer (whose decision shall be final and binding on the contractor) attributable to delay in execution of work within the control of the contractor.</p> <p>The contractor shall keep books of accounts and other documents for the purpose of this condition as may be necessary to clearly arrive at such amounts and shall allow inspection of the same by a duly authorized representative of the Employer and further shall furnish such other information/ document as the Employer may require from time to time.</p>
2.7	<p>Relative Working in the Department:</p> <p>The Contractor shall not be permitted to tender for works with the Employer office in which his near relative is posted as Divisional Accountant or as an officer in any capacity as Engineer. He shall also intimate the names of persons who are near relatives to any Gazetted Officer in the department or in the Ministry who are working with him in any capacity or are subsequently employed by him. Any breach of this condition by the Contractor shall render him liable to be removed from the approved list of contractors of the Department. If, however, the contractor is registered in any other department, he shall be debarred from tendering for any breach of this condition.</p> <p>NOTE: By the term “near relatives” is meant wife, husband, parents and grandparents, children and grand children, brothers and sisters, uncles, aunts and cousins and their corresponding in-laws.</p>
2.8	<p>Prohibition to Work as Contractor</p> <p>No engineer of gazetted rank or other gazetted officer employed in engineering or administrative duties in an engineering department of the Government of India shall work as a Contractor or employee of a Contractor for a period of two years after his retirement from government service without the previous permission of Government of India in writing. This contract is liable to be cancelled if either the Contractor or any of his employees is found at any time to be such a person who had not obtained the permission of Government of India as aforesaid, before submission of the tender or engagement in the contractor's service, as the case may be.</p>
2.9	<p>Provisions of the Apprentices Act to be Complied with</p> <p>The Contractor shall comply with the provisions of the Apprentices Act, 1961 and the rules and orders issued there under from time to time. If he fails to do so, his failure will be a breach of the contract and the Employer may, in his discretion, cancel the contract. The Contractor shall also be liable for any pecuniary liability arising on account of any violation by him of the provisions of the said Act.</p>
3.0	<p>Security for performance:</p>
3.1	<p>Performance Guarantee:</p> <p>(i) The Contractor shall submit an irrevocable Performance Guarantee of 3% (Three percent) of the tendered amount in addition to other deposits mentioned elsewhere in</p>

	<p>the contract for his proper performance of the Contract agreement, (not withstanding and/or without prejudice to any other provisions in the contract) within 21 days of issue of letter of Acceptance. This period can be further extended by the Employer up to a maximum period of 7 days on written request of the contractor stating the reason for delays in procuring the Bank Guarantee, to the satisfaction of the Employer. This guarantee shall be in the form of Government Securities or Fixed Deposit Receipts or Guarantee Bonds of any Scheduled Bank or State Bank India in accordance with the form annexed hereto. In case a fixed deposit receipt is furnished by the contractor to the Government as part of the performance guarantee and the Bank is unable to make payment against the said fixed deposit receipt, the loss caused thereby shall fall on the contractor and the contractor shall forthwith on demand furnish additional security to the Government to make good the deficit.</p> <p>(ii) A letter of intent shall be issued in the first instance information the successful tenderer of the decision of the competent authority to accept his tender and the award letter shall be issued only after the Performance Guarantee in any of the prescribed form is received. In case of failure by the contractor to furnish the performance guarantee within the specified period, Government shall without prejudice to any other right or remedy available in law, be at liberty to forfeit the earnest money absolutely.</p> <p>(iii) The Performance Guarantee shall be initially valid up to the stipulated date of completion plus 12months beyond that. In case the time for completion of work gets enlarged, the Contractor shall get the validity of Performance Guarantee extended to cover such enlarged time for completion of work. After recording of the completion certificate for the work by the competent authority, the performance guarantee shall be returned to the contractor, without any interest.</p> <p>(iv) The Employer shall not make a claim under the performance guarantee except for amounts to which the President of India is entitled under the contract (not withstanding and/or without prejudice to any other provisions in the Contract agreement) in the event of:</p> <p>a) Failure by the Contractor to extend the validity of the Performance Guarantee as described herein above, in which event the Employer may claim the full amount of the Performance Guarantee.</p> <p>b) Failure by the Contractor to pay President of India any amount due, either as agreed by the contractor or determined under any of the Clauses/ Conditions of the Contract, within 30days of the serving of notice to this effect by Employer.</p> <p>(v) In the event of the Contract being determined or rescinded under provision of any of the Clause/ Condition of the agreement, the performance guarantee shall stand forfeited in full and shall be absolutely at the disposal of the President of India, the employer.</p>
3.2	Retention Money/ Security Deposit:
4	Execution of Work
4.1	<p>Works To Be Executed In Accordance With Specifications, Drawings, Orders Etc.:</p> <p>The Contractor shall execute the whole and every part of work i.e. all items of BOQ in the</p>

	<p>most substantial and workmanlike manner both as regards materials and otherwise in every respect in strict accordance with the specifications. The Contractor shall also conform exactly, fully and faithfully to the design, drawings and instructions in writing in respect of the work signed by the Employer and the Contractor shall be furnished free of charge one copy of the contract documents together with specifications, designs, drawings and instructions as are not included in the standard specifications specified in Bidding Data or in any Bureau of Indian Standard or any other, published standard or code or, Schedule of Rates or any other printed publication referred to elsewhere in the contract.</p> <p>The contractor shall comply with the provisions of the contract and with the care and diligence execute and maintain the works and provide all labour and materials, tools and plants including for measurements and supervision of all works, structural plans and other things of temporary or permanent nature required for such execution and maintenance in so far as the necessity for providing these, is specified or is reasonably inferred from the contract. The Contractor shall take full responsibility for adequacy, suitability and safety of all the works and methods of construction.</p>
<p>4.2</p>	<p>Deviations/Variations Extent and Pricing:</p> <p>The Employer shall have power (i) to make alteration in, omissions from, additions to, or substitutions for the original specifications, drawings, designs and instructions that may appear to him to be necessary or advisable during the progress of the work, and (ii) to omit a part of the works in case of non-availability of a portion of the site or for any other reasons and the Contractor shall be bound to carry out the works in accordance with any instructions given to him in writing signed by the Employer and such alterations, omissions, additions or substitutions shall form part of the contract as if originally provided therein and any altered, additional or substituted work which the Contractor may be directed to do in the manner specified above as part of the works, shall be carried out by the Contractor on the same conditions in all respects including price on which he agreed to do the main work except as hereafter provided.</p> <p>The time for completion of the works shall, in the event of any deviations resulting in additional cost over the tendered value sum being ordered, be extended, if requested by the Contractor, as follows:</p> <ul style="list-style-type: none"> (i) In the proportion which the additional cost of the altered, additional or substituted work, bears to the original tendered value plus (ii) 25% of the time calculated in (i) above or such further additional time as may be considered reasonable by the Employer. <p>In the case of extra item(s) the Contractor may within fifteen days of receipt of order or occurrence of the item(s) claim rates, supported by proper analysis, for the work and the Employer shall within one month of the receipt of the claims supported by analysis, after giving consideration to the analysis of the rates submitted by the Contractor, determine the rates on the basis of the market rates and the Contractor shall be paid in accordance with the rates so determined.</p> <p>In the case of substituted items, the rate for the agreement item (to be substituted) and substituted item shall also be determined in the manner as mentioned in the aforesaid para.</p>

	<p>(i) If the market rate for the substituted item so determined is more than the market rate of the agreement item (to be substituted) the rate payable to the Contractor for the substituted item shall be the rate for the agreement item (to be substituted) so increased to the extent of the difference between the market rates of substituted item and the agreement item (to be substituted).</p> <p>(ii) If the market rate for the substituted item so determined is less than the market rate of the agreement item (to be substituted) the rate payable to the contractor for the substituted item shall be the rate for the agreement item (to be substituted) so decreased to the extent of the difference between the market rates of substituted item and the agreement item (to be substituted).</p> <p>In the case of contract items, substituted items, contract cum substituted items, which exceed the limits laid down in Bidding Data, the contractor may within 15 days of receipt of order or occurrence of the excess, claim revision of the rates, supported by proper analysis, for the work in excess of the above mentioned limits, provided that if the rates so claimed are in excess of the rates specified in the schedule of quantities the Employer shall within one month of receipt of the claims supported by analysis, after giving consideration to the analysis of the rates submitted by the contractor, determine the rates on the basis of the market rates and the contractor shall be paid in accordance with the rates so determined.</p> <p>The provisions of the preceding paragraph shall also apply to the decrease in the rates of items for the work in excess of the limits laid down in Bidding Data, and the Employer shall after giving notice to the contractor within one month of occurrence of the excess and after taking into consideration any reply received from him within 15 days of the receipt of the notice, revise the rates for the work in question within one month of the expiry of the said period of 15 days having regard to the market rates.</p> <p>The Contractor shall send to the Employer once every 3 months an up to date account giving complete details of all claims for additional payments to which the Contractor may consider himself entitled and of all additional work ordered by the Employer which he has executed during the preceding quarter failing which the Contractor shall be deemed to have waived his right. However, the Employer may authorize consideration of such claims on merits.</p>
<p>4.3</p>	<p>Action in Case Work not Done as per Specifications:</p> <p>All works under or in course of execution or executed in pursuance of the contract shall at all times be open and accessible to the inspection and supervision of the Employer, his authorized subordinates incharge of the work and all the superior officers, officer of the Quality Control Organization of the Department and of the Chief Technical Examiner's Office, and the Contractor shall, at all times, during the usual working hours and at all other times at which reasonable notice of the visit of such officers has been given to the Contractor, either himself be present to receive orders and instructions or have a responsible agent duly accredited in writing, present for that purpose. Orders given to the Contractor's agent shall be considered to have the same force as if they had been given to the Contractor himself.</p> <p>If it shall appear to the Employer or his authorized subordinates in-charge of the work or to the Engineer in charge of Quality Control or his subordinate officers or to the Chief Technical Examiner or his subordinate officers, that any work has been executed with unsound, imperfect, or unskilful workmanship, or with materials or articles provided by him for the execution of the work which are unsound or of a quality inferior to that contracted or</p>

	<p>otherwise not in accordance with the contract the Contractor shall, on demand in writing which shall be made within 6 months of the completion of the work from the Employer specifying the work, materials or articles complained of notwithstanding that the same may have been passed, certified and paid for forthwith rectify, or remove and reconstruct the work so specified in whole or in part, as the case may require or as the case may be, remove the materials or articles so specified and provide other proper and suitable materials or articles at his own charge and cost. In the event of the failing to do so within a period specified by the Employer in his demand aforesaid, then the Contractor shall be liable to pay compensation at the same rate as under clause 8.2 of the contract (for non-completion of the work in time) for this default.</p> <p>In such case the Employer may not accept the item of work at the rates applicable under the contract but may accept such items at reduced rates as the competent authority may consider reasonable during the preparation of on account bills or final bill if the item is so acceptable without detriment to the safety and utility of the item and the structure or he may reject the work outright without any payment and/or get it and other connected and incidental items rectified, or removed and re-executed at the risk and cost of the Contractor. Decision of the Employer to be conveyed in writing in respect of the same will be final and binding on the Contractor.</p>
<p>4.4</p>	<p>Contractor Liable For Damages, Defects During Defects liability period:</p> <p>The work or any part is being executed, or if any damage shall happen to the work while in progress, from any cause whatever or if any defect, shrinkage or other faults appear in the work within the period as specified in the Bidding Document after a certificate final or otherwise of its completion shall have been given by the Employer as aforesaid arising out of defect or improper materials or workmanship the Contractor shall upon receipt of a notice in writing on that behalf make the same good at his own expense or in default the Employer cause the same to be made good by other workmen and deduct the expense from any sums that may be due or at any time thereafter may become due to the Contractor, or from his security deposit or the proceeds of sale thereof or of a sufficient portion thereof. The security deposit of the Contractor shall not be refunded before the expiry defects liability period after the issue of the certificate final or otherwise, of completion of work, or till the final bill has been prepared and passed whichever is later.</p>
<p>4.5</p>	<p>Contractor Shall Supply Tools & Plants, etc. :</p> <p>The Contractor shall provide at his own cost all materials , plant, tools, appliances , implements, ladders, cordage, tackle, scaffolding and temporary works required for the proper execution of the work, whether original, altered or substituted and whether included in the specifications or other documents forming part of the contract or referred to in these conditions or not, or which may be necessary for the purpose of satisfying or complying with the requirements of the Employer as to any matter as to which under these conditions he is entitled to be satisfied, or which he is entitled to require together with carriage thereof to and from the work. The Contractor shall also supply without charge the requisite number of persons with the means and materials, necessary for the purpose offsetting out works, and counting, weighing and assisting the measurement for examination at any time and from time to time of the work or materials. Failing his so doing, the same may be provided by the Employer at the expense of the Contractor and the expenses may be deducted, from any money due to the Contractor, under this contract or otherwise and/or from his security deposit or the proceeds of sale thereof, or of a sufficient portions thereof.</p>

4.6 Employment of Technical Staff and Employees:

Contractors Superintendence, Supervision, Technical Staff & Employees

- (i) The contractor shall provide all necessary superintendence during execution of the work and all along thereafter as may be necessary for proper fulfilling of the obligations under the contract. The contractor shall immediately after receiving letter of acceptance of the Bid and before commencement of the work, intimate in writing to the Employer the name(s), qualifications, experience, age, address(s) and other particulars along with certificates of the principal technical representative to be in charge of the work and other technical representative(s) who will be supervising the work. Minimum requirement of such technical representative(s) and their qualifications and experience shall not be lower than specified in Bidding Document. The Employer shall within 3 days of receipt of such communication intimate in writing his approval or otherwise of such representative(s) to the contractor. Any such approval may at any time be withdrawn and in case of such withdrawal, the contractor shall appoint another such representative(s) according to the provisions of this clause. Decision of the bid accepting authority shall be final and binding on the contractor in this respect. Such a principal technical representative and other technical representative(s) shall be appointed by the contractor soon after receipt of the approval from Employer and shall be available at site before start of work. All the provisions applicable to the principal technical representative under the clause will also be applicable to other technical representative(s). The principal technical representative and other technical representative(s) shall be present at the site of work for supervision at all times when any construction activity is in progress and also present himself/themselves, as required, to the Employer and/or his designated representative to take instructions. Instructions given to the technical representative(s) shall be deemed to have the same post as if these have been given to the contractor. The principal technical representative(s) shall be actually available at site fully during all stages of execution of work, during recording/checking/test checking of measurement of works and whenever so required by the Employer and shall also note down instructions conveyed by the Employer or his designated representative(s) in the Site Order Book and shall affix his/their signature(s) in token of noting down the instructions and in token of acceptance of measurements/ checked measurements/ test checked measurements. The representative(s) shall not look after any other work. Substitutes, duly approved by Employer of the work in similar manner as aforesaid shall be provided in event of absence of any of the representative(s) by more than two days. If the Employer, whose decision in this respect is final and binding on the contractor, is convinced that no such technical representative(s) is/are effectively appointed or/is/are effectively attending or fulfilling the provision of this clause, a recovery (non-refundable) shall be effected from the contractor as specified in Bidding Data and the decision of the Employer as recorded in the Site Order Book and measurements recorded, checked/test checked in Measurement Books shall be final and binding on the contractor. Further if the contractor fails to appoint a suitable principal technical representative and/or other technical representative(s) and if such appointed persons are not effectively present or are absent by more than two days without duly approved substitute or do not discharge their responsibilities satisfactorily, the Employer shall have full powers to suspend the execution of the work until such date as a suitable other technical representative(s) is/are appointed and the contractor shall be held responsible for the delay so caused to the work. The contractor shall submit a certificate of employment of the technical

	<p>representative(s) along with every on account bill/final bill and shall produce evidence if at any time so required by the Employer.</p> <p>(ii) The contractor shall provide and employ on the site only such technical assistants as are skilled and experienced in their respective fields and such foremen and supervisory staff as are competent to give proper supervision to the work. The contractor shall provide and employ skilled, semiskilled and unskilled labour as is necessary for proper and timely execution of the work. The minimum strength of trained and certified workers shall be 5 % of the total strength employed. The accepted certification shall be granted by government authorize organizations.</p> <p>(iii) The Employer shall be at liberty to object to and require the Contractor to remove from the works any person who in his opinion misconducts himself, or is incompetent or negligent in the performance of his duties or whose employment is otherwise considered by the Employer to be undesirable. Such person shall not be employed again at works site without the written permission of the Employer and the persons so removed shall be replaced as soon as possible by competent substitutes.</p>
5.0	Materials and Machineries
5.1	<p>Materials to be Provided by the Contractor :</p> <p>(i) The Contractor shall, at his own expense, provide all materials, required for the works other than those which are stipulated to be supplied by the Employer.</p> <p>The Contractor shall, at his own expense and without delay, supply to the Employer samples of materials to be used on the work and shall get these approved in advance. All such materials to be provided by the Contractor shall be in conformity with the specifications laid down or referred to in the contract. The Contractor shall, if requested by the Employer furnish proof, to the satisfaction of the Employer that the materials so comply. The Employer shall within 10 days of supply of samples or within such further period as he may require intimate to the Contractor in writing whether samples are approved by him or not. If samples are not approved, the Contractor shall forthwith arrange to supply to the Employer for his approval fresh samples complying with the specifications laid down in the contract. When materials are required to be tested in accordance with specifications, approval of the Employer shall be issued after the test results are received.</p> <p>The Contractor shall at his risk and cost submit the samples of materials to be tested or analysed and shall not make use of or incorporate in the work any materials represented by the samples until the required tests or analysis have been made and materials finally accepted by the Employer. The Contractor shall not be eligible for any claim or compensation either arising out of any delay in the work or due to any corrective measures required to be taken on account of and as a result of testing of materials.</p> <p>The contractor shall, at his risk and cost, make all arrangements and shall provide all facilities as the Employer may require for collecting, and preparing the required number of samples for such tests at such time and to such place or places as may be directed by the Employer and bear all charges and cost of testing unless specifically provided for otherwise elsewhere in the contract or specifications. The Employer or his authorized representative shall at all times have access to the works and to all workshops and places where work is being prepared or from where materials, manufactured articles or machinery are being obtained for the works and the Contractor shall afford every facility and every assistance in obtaining the right to such access.</p> <p>The Employer shall have full powers to require the removal from the premises of all materials which in his opinion are not in accordance with the specifications and in case of default, the Employer shall be at liberty to employ at the expense of the Contractor, other</p>

	<p>persons to remove the same without being answerable or accountable for any loss or damage that may happen or arise to such materials. The Employer shall also have full powers to require other proper materials to be substituted thereof and in case of default, the Employer because the same to be supplied and all costs which may attend such removal and substitution shall be borne by the Contractor.</p> <p>(ii) Mobilization advance</p> <p>Mobilization advance not exceeding 10% of the tendered value may be given, if requested by the contractor in writing within one month of the order to commence the work. Such advance shall be in two or more installments to be determined by the Engineer-in- Charge at his sole discretion. The first installment of such advance shall be released by the Engineer-in-charge to the contractor on a request made by the contractor to the Engineer-in-Charge in this behalf. The second and subsequent installments shall be released by the Engineer-in- Charge only after the contractor furnishes a proof of the satisfactory utilization of the earlier installment to the entire satisfaction of the Engineer-in-Charge. Before any installment of advance is released, the contractor shall execute a Bank Guarantee Bonds not more than 6 in number from Scheduled Bank for the amount equal to 110% of the amount of advance and valid for the period till recovery of advance. This (Bank Guarantee from Scheduled Bank for the amount equal to 110% of the balance amount of advance) shall be kept renewed from time to time to cover the balance amount and likely period of complete recovery.</p> <p>(iii) Interest & Recovery</p> <p>The mobilization advance in (ii) above bear simple interest at the rate of 10 percent per annum and shall be calculated from the date of payment to the date of recovery, both days inclusive, on the outstanding amount of advance. Recovery of such sums advanced shall be made by the deduction from the contractors bills commencing after first ten percent of the gross value of the work is executed and paid, on pro-rata percentage basis to the gross value of the work billed beyond 10% in such a way that the entire advance is recovered by the time eighty percent of the gross value of the contract is executed and paid, together with interest due on the entire outstanding amount up to the date of recovery of the installment.</p> <p>If the circumstances are considered reasonable by the Engineer-in-Charge, the period mentioned in (ii) and (iii) for request by the contractor in writing for grant of mobilization advance may be extended at the discretion of the Engineer-in-Charge.</p>
<p>5.2</p>	<p>Dismantled Material Government Property:</p> <p>The Contractor shall treat all materials obtained during dismantling of a structure, excavation of the site for a work, etc. as Government's property and such materials shall be disposed off to the best advantage of Government according to the instructions in writing issued by the Employer.</p>
<p>5.3</p>	<p>Arrangement for Water for Construction:</p> <p>The contractor(s) shall make his/ their own arrangements for water required for the work and nothing extra will be paid for the same. This will be subject to the following conditions.</p> <p>(i) That the water used by the contractor(s) shall be fit for construction purposes to the satisfaction of the Engineer-in-Charge.</p>

	(ii) The Engineer-in-Charge shall make alternative arrangements for supply of water at the risk and cost of contractor(s) if the arrangements made by the contractor(s) for procurement of water are in the opinion of the Engineer-in- Charge, unsatisfactory.
5.4	Deleted
6.0	Measurement and Payment
6.1	<p>Measurements of Work Done:</p> <p>Engineer in charge shall, except as otherwise provided, ascertain and determine by measurement the value in accordance with the contract of work done.</p> <p>All measurement of all items having financial value shall be entered in Computerized Measurement Book and/or level field book so that a complete record is obtained of all works performed under the contract.</p> <p>All measurements and levels shall be taken jointly by the Engineer in charge or his authorized representative and by the contractor or his authorized representative from time to time during the progress of the work and such measurements shall be signed and dated by the Engineer and the contractor or their representatives in token of their acceptance. If the contractor objects to any of the measurements recorded, a note shall be made to that effect with reason and signed by both the parties.</p> <p>If for any reason the contractor or his authorized representative is not available and the work of recording measurements is suspended by the Employer or his representative, the Employer shall not entertain any claim from contractor for any loss or damages on this account. If the contractor or his authorized representative does not remain present at the time of such measurements after the contractor or his authorized representative has been given a notice in writing three (3) days in advance or fails to countersign or to record objection within a week from the date of the measurement, then such measurements recorded in his absence by the Engineer in Charge or his representative shall be deemed to be accepted by the Contractor.</p> <p>The contractor shall, without extra charge, provide all assistance with every appliance, labour and other things necessary for measurements and recording levels.</p> <p>Except where any general or detailed description of the work expressly shows to the contrary, measurements shall be taken in accordance with the procedure set forth in the specifications notwithstanding any provision in the relevant Standard Method of measurement or any general or local custom. In the case of items which are not covered by specifications, measurements shall be taken in accordance with the relevant standard method of measurement issued by the Bureau of Indian Standards and if for any item no such standard is available then a mutually agreed method shall be followed.</p> <p>The Contractor shall give not less than seven days' notice to the Employer or his authorized representative in-charge of the work before covering up or otherwise placing beyond the reach of measurement any work in order that the same may be measured and correct dimensions thereof be taken before the same is covered up or placed beyond the reach of measurement and shall not cover up and place beyond reach of measurement any work without consent in writing of the Employer or his authorized representative in-charge of the work who shall within the aforesaid period of seven days inspect the work, and if any work shall be covered up or placed beyond the reach of measurements without such notice having been given or the Employer's consent being obtained in writing the same shall be uncovered at the Contractor's expense, or in default thereof no payment or allowance shall be made for such work or the materials with which the same was executed.</p> <p>Employer or his authorized representative may cause either themselves or through another officer of the department to check the measurements recorded jointly or otherwise as</p>

	<p>aforesaid and all provisions stipulated herein above shall be applicable to such checking of measurements or levels.</p> <p>It is also a term of this contract that recording of measurements of any item of work in the measurement book and/or its payment in the interim, on account or final bill shall not be considered as conclusive evidence as to the sufficiency of any work or material to which it relates nor shall it relieve the Contractor from liabilities from any over measurement or defects noticed till completion of the defects liability period.</p>
6.2	Deleted
6.3	<p>Completion Certificate And Completion Plans:</p> <p>Within 10 days of the completion of the work, the Contractor shall give notice of such completion to the Employer and within 30 days of the receipt of such notice the Employer shall inspect the work and if there is no defect in the work, shall furnish the Contractor with a final certificate of completion, otherwise a provisional certificate of physical completion indicating defects (a) to be rectified by the contractor and/or (b) for which payment will be made at reduced rates, shall be issued. But no final certificate of completion shall be issued, nor shall the work be considered to be complete until the contractor shall have removed from the premises on which the work shall be executed all scaffolding, surplus materials, rubbish and all huts and sanitary arrangements required for his/their work people on the site in connection with the execution of the works as shall have been erected or constructed by the contractor(s) and cleaned off the dirt from all wood work, doors, windows, walls, floor or other parts of the building, in, upon, or about which the work is to be executed or of which he may have had possession for the purpose of the execution thereof, and not until the work shall have been measured by the Employer. If the contractor shall fail to comply with the requirements of this Clause as to removal of scaffolding, surplus materials and rubbish and all huts and sanitary arrangements as aforesaid and cleaning off dirt on or before the date fixed for the completion of work, the Employer may at the expense of the contractor remove such scaffolding, surplus materials and rubbish etc., and dispose of the same as he thinks fit and clean off such dirt as aforesaid, and the contractor shall have no claim in respect of scaffolding or surplus materials as aforesaid except for any sum actually realized by the sale thereof.</p>
6.4	<p>Payment of Final Bill:</p> <p>The final bill shall be submitted by the Contractor in the same manner as specified in interim bills within one months of physical completion of the work or within one month of the date of the final certificate of completion furnished to the Employer whichever is earlier. No further claims shall be made by the Contractor after submission of the final bill and these shall be deemed to have been waived and extinguished. Payments of those items of the bill in respect of which there is no dispute and of items in dispute, for quantities and rates as approved by Employer, will, as far as possible be made within a period of three months, the period being reckoned from the date of receipt of the bill by the Engineer, complete with account of dismantled materials.</p>
6.5	<p>Advance:</p> <p>Advance as per extant rule in GFR and procurement manual will be admissible.</p>
6.6	Deleted
6.7	Deleted
7.0	Observance of Labour Regulation
7.1	Recovery Of Compensation Paid To Workmen:

	<p>In every case in which by virtue of the provisions sub-section (1) of Section 12, of the Workmen's Compensation Act, 1923, Government is obliged to pay compensation to a workman employed by the contractor, in execution of the works, Government will recover from the contractor, the amount of the compensation so paid; and, without prejudice to the rights of the Government under sub-section (2) of Section 12, of the said Act, Government shall be at liberty to recover such amount or any part thereof by deducting it from the security deposit or from any sum due by Government to the contractor whether under this contract or otherwise. Government shall not be bound to contest any claim made against it under sub-section (1) Section 12, of the said Act, except on the written request of the contractor and upon his giving to Government full security for all costs for which Government might become liable in consequence of contesting such claim.</p>
7.2	<p>Ensuring Payment and Amenities To Workman, If Contractor Fails:</p> <p>In every case in which by virtue of the provisions of the Contract Labour (Regulation and Abolition) Act, 1970, and of the Contract Labour (Regulation and Abolition) Central Rules, 1971, Government is obliged to pay any amounts of wages to a workman employed by the contractor in execution of the works, or to incur any expenditure in providing welfare and health amenities required to be provided under the above said Act and the rules under Clause 7.10 or under the Contractor's Labour Regulations, or under the Rules framed by Government from time to time for the protection of health and sanitary arrangements for workers employed by Contractors, Government will recover from the contractor, the amount of wages so paid or the amount of expenditure so incurred; and without prejudice to the rights of the Government under sub-section(2) of Section 20, and sub-section (4) of Section 21, of the Contract Labour (Regulation and Abolition) Act, 1970, Government shall be at liberty to recover such amount or any part thereof by deducting it from the security deposit or from any sum due by Government to the contractor whether under this contract or otherwise Government shall not be bound to contest any claim made against it under sub-section (1) of Section 20, sub-section (4) of Section 21, of the said Act, except on the written request of the contractor and upon his giving to the Government full security for all costs for which Government might become liable in contesting such claim.</p>
7.3	<p>Labour Laws to be Complied</p> <p>The Contractor shall obtain a valid licence under the Contract Labour (R&A) Act 1970, and the Contract Labour (Regulation and Abolition) Central Rules 1971, before the commencement of the work, and continue to have a valid license until the completion of the work. The contractor shall also abide by the provisions of the Child Labour (Prohibition and Regulation) Act, 1986.</p> <p>The contractor shall also comply with the provisions of the building and other Construction Workers (Regulation of Employment & Conditions of Service) Act, 1996 and the building and other Construction Workers Welfare Cess Act, 1996.</p> <p>Any failure to fulfil these requirements shall attract the penal provisions of this contract arising out of the resultant non-execution of the work.</p> <p>No labour below the age of fourteen years shall be employed on the work.</p>
7.4	<p>Payment of Wages:</p> <p>(i) The Contractor shall pay to labour employed by him either directly or through sub-contractors, wages not less than fair wages as defined in Contractor's Labour Regulations or as per the provisions of the Contract Labour (Regulation and Abolition) Act 1970 and the contract Labour (Regulation and Abolition) Central Rules, 1971, wherever applicable.</p>

	<ul style="list-style-type: none"> (ii) The Contractor shall, notwithstanding the provisions of any contract to the contrary, cause to be paid fair wage to labour indirectly engaged on the work, including any labour engaged by his subcontractors in connection with the said work, as if the labour had been immediately employed by him. (iii) In respect of all labour directly or indirectly employed in the works for performance of the contractor's part of this contract, the Contractor shall comply with or cause to be complied with the contractor's Labour Regulations made by Government from time to time in regard to payment of wages, wage period, deductions from wages recovery of wages not paid and deductions unauthorisedly made, maintenance of wage books or wage slips, publication of scale of wages and other terms of employment, inspection and submission of periodical returns and all other matters of the like nature or as per the provisions of the Contract Labour (Regulation and Abolition) Act 1970, and the Contract Labour (Regulation and Abolition) Central Rules, 1971, wherever applicable. (iv) (a) The Employer concerned shall have the right to deduct from the moneys due to the contractor any sum required or estimated to be required for making good the loss suffered by a worker or workers by reason of non-fulfilment of the conditions of the contract for the benefit of the workers, non-payment of wages or of deductions made from his or their wages which are not justified by their terms of the contract or non-observance of the Regulations. (b) Under the provision of Minimum Wages (Central) Rules 1950, the contractor is bound to allow to the labours directly or indirectly employed in the works one day rest for 6 days continuous work and pay wages at the same rate as for duty. In the event of default, the Employer shall have the right to deduct the sum or sums not paid on account of wages for weekly holidays to any labours and pay the same to the persons entitled thereto from any money due to the contractor by the Employer concerned. (v) The contractor shall comply with the provisions of the Payment of Wages Act, 1936, Minimum Wages Act, 1948, Employees Liability Act, 1938, Workmen's Compensation Act, 1923, Industrial Disputes Act, 1947, Maternity Benefits Act, 1961, and the Contractor's Labour (Regulation and Abolition) Act 1970, or the modifications thereof or any other laws relating thereto and the rules made there under from time to time. (vi) The contractor shall indemnify and keep indemnified Government against payments to be made under and for the observance of the laws aforesaid and the Contractor's Labour Regulations without prejudice to his right to claim indemnity from his sub-contractors. (vii) The laws aforesaid shall be deemed to be a part of this contract and any breach thereof shall be deemed to be a breach of this contract. (viii) Whatever is the minimum wage for the time being, or if the wage payable is higher than such wage, such wage shall be paid by the Contractor to the workmen directly without the intervention of Jamadar and that Jamadar shall not be entitled to deduct or recover any amount from the minimum wage payable to the workmen as and by way of commission or otherwise. (ix) The contractor shall ensure that no amount by way of commission or otherwise is deducted or recovered by the Jamadar from the wage of workmen.
7.5	<p>Arrangement for Safety Provisions</p> <p>In respect of all labour directly or indirectly employed in the work for the performance of the</p>

	<p>Contractor's part of this contract, the Contractor shall at his own expense arrange for the safety provisions as per. Safety Code framed from time to time and shall at his own expense provide for all facilities in connection therewith. In case the Contractor fails to make arrangement and provide necessary facilities as aforesaid, he shall be liable to pay a penalty of Rs.500/- for each default and in addition the Employer shall be at liberty to make arrangement and provide facilities as aforesaid and recover the costs incurred in that behalf from the Contractor.</p>
<p>7.6</p>	<p>Submission Of Labour Return</p> <p>The contractor shall submit on or before the 1st day of February following the end of year to which it relates, to the Employer a true statement showing in respect of thesecondhalfoftheprecedingmonthandthefirsthalfofthecurrentmonthrespectively:</p> <ol style="list-style-type: none"> (1) the number of labourers employed by him on the work, (2) their working hours, (3) the wages paid to them, (4) the accidents that occurred during the said fortnight showing the circumstances under which they happened and the extent of damage and injury caused by them, and (5) the number of female workers who have been allowed maternity benefit according to Clause 7.8 and the amount paid to them. <p>Failing which the Contractor shall be liable to pay to Government, a sum not exceeding Rs.500/- for each default or materially incorrect statement. The decision of the Employer shall be final in deducting from any bill due to the Contractor the amount levied as fine and be binding on the contractor.</p>
<p>7.7</p>	<p>Rules Framed By Govt. To Be Complied</p> <p>In respect of all labour directly or indirectly employed in the works for the performance of the Contractor's part of this contract, the Contractor shall comply with or cause to be complied with all the rules framed by Government from time to time for the protection of health and sanitary arrangements for workers employed by the contractors.</p>
<p>7.8</p>	<p>Leave And Pay Regulations</p> <p>Leave and pay during leave shall be regulated as follows:</p> <ol style="list-style-type: none"> 1. Leave: <ol style="list-style-type: none"> (i) in the case of delivery - maternity leave not exceeding 8 weeks, 4 weeks up to and including the day of delivery and 4 weeks following that day, (ii) in the case of miscarriage – up to 3 weeks from the date of miscarriage. 2. Pay: <ol style="list-style-type: none"> (i) in the case of delivery - leave pay during maternity leave will be at the rate of the women's average daily earnings, calculated on total wages earned on the days when full time work was done during a period of 3 months immediately preceding the date on which she gives notice that she expects to be confined or at the rate of Rupee one only a day whichever is greater. (ii) in the case of miscarriage - leave pay at the rate of average daily earning calculated on the total wages earned on the days when full time work was done during a period of three months immediately preceding the date of

	<p style="text-align: center;">such miscarriage.</p> <p>3. Conditions for the grant of Maternity Leave: No maternity leave benefit shall be admissible to a woman unless she has been employed for a total period of not less than six months immediately preceding the date on which she proceeds on leave.</p> <p>4. The contractor shall maintain a register of Maternity (Benefit) in the Prescribed Form, and the same shall be kept at the place of work.</p>
7.9	<p>Default of any of the Provisions of Contractors' Labour Regulations</p> <p>In the event of the contractor(s) committing a default or breach of any of the provisions , Contractor's Labour Regulations and Model Rules for the protection of health and sanitary arrangements for the workers as amended from time to time or furnishing any information or submitting or filing any statement under the provisions of the above Regulations and Rules which is materially incorrect, he/they shall, without prejudice to any other liability, pay to the Govt. a sum not exceeding Rs500/- for every default, breach or furnishing, making, submitting, filing such materially incorrect statements and in the event of the contractor(s) defaulting continuously in this respect, the penalty may be enhanced to Rs.200/- per day for each day of default subject to a maximum of 5 per cent of the estimated cost of the work put to tender. The decision of the Employer shall be final and binding on the parties.</p> <p>Should it appear to the Employer that the contractor(s) is/ are not properly observing and complying with the provisions of the Contractor's Labour Regulations and Model Rules and the provisions of the Contract Labour (Regulation and Abolition) Act 1970, and the Contract Labour (R & A) Central Rules 1971, for the protection of health and sanitary arrangements for work-people employed by the contractor(s) (hereinafter referred as "the said Rules") the Employer shall have power to give notice in writing to the contractor(s) requiring that the said Rules be complied with and the amenities prescribed therein be provided to the work-people within a reasonable time to be specified in the notice. If the contractor(s) shall fail within the period specified in the notice to comply with and/ observe the said Rules and to provide the amenities to the work-people as aforesaid, the Employer shall have the power to provide the amenities hereinbefore mentioned at the cost of the contractor(s). The contractor(s) shall erect, make and maintain at his/their own expense and to approved standards all necessary tents and sanitary arrangements required for his/their work-people on the site in connection with the execution of the works, and if the same shall not have been erected or constructed, according to approved standards, the Employer shall have power to give notice in writing to the contractor(s) requiring that the said tents and sanitary arrangements be remodelled and/or reconstructed according to approved standards, and if the contractor(s) shall fail to remodel or reconstruct such huts and sanitary arrangements according to approved standards within the period specified in the notice, the Employer shall have the power to remodel or reconstruct such huts and sanitary arrangements according to approved standards at the cost of the contractor(s).</p>
7.10	<p>Provision Of Tents, Water Supply to the Labourer</p> <p>The contractor(s) shall at his/their own cost provide his/their labour with following facilities</p> <ol style="list-style-type: none"> a) Sufficient numbers of tents. b) Sufficient numbers of latrines and urinals covered by tents. c) Sufficient quantity of water for drinking and other purposes. d) Proper drainage and sanitation.
7.11	<p>Removal of Contractor's Employee</p>

	<p>The Employer may require the contractor to dismiss or remove from the site of the work any person or persons in the contractors' employ upon the work who may be incompetent or misconduct himself and the contractor shall forthwith comply with such requirements.</p>
8.0	Operation of contract
8.1	<p>Time and Extension for Delay</p> <p>The time allowed for execution of the Works as specified in the Bidding data or the extended time in accordance with these conditions shall be the essence of the Contract. The execution of the works shall commence from such time period as mentioned in letter of acceptance or from the date of handing over of the site whichever is later. If the Contractor commits default in commencing the execution of the work as aforesaid, Government shall without prejudice to any other right or remedy available in law, be at liberty to forfeit the earnest money & performance guarantee absolutely.</p> <p>As soon as possible after the Contract is concluded the Contractor shall submit a Time and Progress Chart and get it approved by the Employer. It shall indicate the forecast of the dates of commencement and completion of various trades of sections of the work and may be amended as necessary by agreement between the Employer and the Contractor and further to ensure good progress during the execution of the work, the contractor shall in all cases complete the work as per the schedule.</p> <p>If the work(s) be delayed by:</p> <ul style="list-style-type: none"> (i) force majeure events, or (ii) abnormally bad weather, or (iii) serious loss or damage by fire, or (iv) civil commotion, local commotion of workmen, strike (excluding by Party's employees) or lockout (excluding by Party's employees), affecting any of the trades employed on the work , or (v) delay on the part of other contractors or tradesmen engaged by Employer in executing work not forming part of the Contract, or (vi) any other cause which, in the absolute discretion of the authority mentioned in Bidding Data is beyond the Contractor's control and not brought about at the instance of the Contractor claiming to be affected by such event. <p>then upon the happening of any such event causing delay, the Contractor shall immediately give notice thereof in writing to the Employer but shall nevertheless use constantly his best endeavours to prevent or make good the delay and shall do all that may be reasonably required to the satisfaction of the Employer to proceed with the works.</p> <p>Request for rescheduling of work and extension of time, to be eligible for consideration, shall be made by the Contractor in writing within 14 days of the happening of the event causing delay on the prescribed form. The Contractor may also, if practicable, indicate in such a request the period for which extension is desired.</p> <p>In any such case the authority mentioned in Bidding Data may give a fair and reasonable extension of time. Such extension shall be communicated to the Contractor by the Employer in writing, within 2 months of the date of receipt of such request. Non application by the contractor for extension of time shall not be a bar for giving a fair and reasonable extension by the Employer and this shall be binding on the contractor.</p>
8.2	Compensation For Delay

	<p>If the contractor fails to maintain the required progress in terms of clause 8.1 or to complete the work and clear the site on or before the contract or extended date of completion, he shall, without prejudice to any other right or remedy available under the law to the Government on account of such breach, pay as agreed compensation the amount calculated at the rates stipulated below as the competent authority (whose decision in writing shall be final and binding) may decide on the amount of tendered value of the work for every completed day/week (as applicable) that the progress remains below that specified in Clause 8.1 or that the work remains incomplete.</p> <p>This will also apply to items or group of items for which a separate period of completion has been specified.</p> <p>Compensation @ 0.5% (zero point five percent) of the total contract value per week of delay and part thereof subject to maximum of 10% of contract value.</p>
<p>8.3</p>	<p>When Contract Can Be Determined</p> <p>Subject to other provisions contained in this clause, the Employer may, without prejudice to his any other rights or remedy against the Contractor in respect of any delay, inferior workmanship, any claims for damages and/or any other provisions of this contract or otherwise, and whether the date of completion has or has not elapsed, by notice in writing absolutely determine the contract in any of the following cases:</p> <ul style="list-style-type: none"> (i) If the contractor having been given by the Employer a notice in writing to rectify, reconstruct or replace any defective work or that the work is being performed in an inefficient or otherwise improper or un-workman like manner shall omit to comply with the requirement of such notice for a period of 7 days thereafter. (ii) If the contractor being a company shall pass a resolution or the court shall make an order that the company shall be wound up or if a receiver or a manager on behalf of a creditor shall be appointed or if circumstances shall arise which entitle the court or the creditor to appoint a receiver or a manager or which entitle the court to make a winding up order. (iii) If the contractor has, without reasonable cause, suspended the progress of the work or has failed to proceed with the work with due diligence so that in the opinion of the Employer (which shall be final and binding) he will be unable to secure completion of the work by the date for completion and continues to do so after a notice in writing of seven days from the Employer. (iv) If the contractor fails to complete the work within the stipulated date or items of work with individual date of completion, if any stipulated, on or before such date(s) of completion and does not complete them within the period specified in a notice given in writing in that behalf by the Employer. (v) If the contractor persistently neglects to carry out his obligations under the contract and/or commits default in complying with any of the terms and conditions of the contract and does not remedy it or take effective steps to remedy it within 7 days after a notice in writing is given to him in that behalf by the Employer. (vi) If the contractor commits any acts mentioned in Clause 2.1 hereof; or (vii) If the work is not started by the contractor within 1/8th of the stipulated time. When the contractor has made himself liable for action under any one or more of the cases aforesaid, the Employer on behalf of the President of India shall have powers:

	<p>a) To determine or rescind the contract as aforesaid (of which termination or rescission notice in writing to the contractor under the hand of the Employer shall be conclusive evidence). Upon such determination or rescission, the Earnest Money Deposit, Security Deposit already recovered and Performance Guarantee under the contract shall be liable to be forfeited and shall be absolutely at the disposal of the Government/ the Employer.</p> <p>b) After giving notice to the contractor to measure up the work of the contractor and to take such whole, or the balance or part thereof, as shall be un-executed out of his hands and to give it to another contractor to complete the work. The contractor, whose contract is determined or rescinded as above, shall not be allowed to participate in the tendering process for the balance work.</p> <p>In the event of above courses being adopted by the Employer, the contractor shall have no claim to compensation for any loss sustained by him by reasons of his having purchased or procured any materials or entered into any engagements or made any advances on account or with a view to the execution of the work or the performance of the contract. And in case action is taken under any of the provision aforesaid, the contractor shall not be entitled to recover or be paid any sum for any work thereof or actually performed under this contract unless and until the Employer has certified in writing the performance of such work and the value payable in respect thereof and he shall only be entitled to be paid the value so certified.</p>
<p>8.4</p>	<p>Foreclosure of Contract due to Abandonment or Reduction In Scope of Work</p> <p>If at any time after acceptance of the bid, the Employer/ Government shall decide to abandon or reduce the scope of the works for any reason whatsoever and hence not require the whole or any part of the works to be carried out, the Employer shall give notice in writing to that effect to the contractor and the contractor shall act accordingly in the matter. The contractor shall have no claim to any payment of compensation or otherwise whatsoever, on account of any profit or advantage which he might have derived from the execution of the works in full but which he did not derive in consequence of the foreclosure of the whole or part of the works.</p> <p>The contractor shall be paid at contract rates full amount for works executed at site and, in addition, reasonable amount as certified by the Engineer for the items hereunder mentioned which could not be utilised on the work to the full extent in view of the foreclosure:</p> <ul style="list-style-type: none"> (i) Any expenditure incurred on preliminary site work, (ii) Government shall have the option to take over contractor's materials or any part thereof either brought to site or of which the contractor is legally bound to accept delivery from suppliers (for incorporation in or incidental to the work) provided, however, Government shall be bound to take over the materials or such portions thereof as the contractor does not desire to retain. For materials taken over or to be taken over by Government, cost of such materials as detailed by Engineer shall be paid. The cost shall, however, take into account purchase price, cost of transportation and deterioration or damage which may have been caused to materials whilst in the custody of the contractor. (iii) Reasonable compensation for transfer of T & P from site to contractor's permanent

	<p>stores or to his other works, whichever is less. If T & P are not transported to either of the said places, no cost of transportation shall be payable.</p> <p>(iv) Reasonable compensation for repatriation of contractor's site staff and imported labour to the extent necessary.</p> <p>The contractor shall, if required by the Engineer furnish to him books of account, wage books, time sheets and other relevant documents and evidence as may be necessary to enable him to certify the reasonable amount payable under this condition.</p> <p>The reasonable amount of items on (i), (iii) and (iv) above shall not be in excess of 2% of the cost of the work remaining incomplete on the date of closure, i.e. total stipulated cost of the work as per accepted bid less the cost of work actually executed under the contract and less the cost of contractor's materials at site taken over by the Government as per item (ii) above. Provided always that against any payments due to the contractor on this account or otherwise, the Employer shall be entitled to recover or be credited with any outstanding balances due from the contractor for advance paid in respect of any tool, plants and materials and any other sums which at the date of termination were recoverable by the Government from the contractor under the terms of the contract.</p>
<p>8.5</p>	<p>Cancellation Of Contract In Full Or Part</p> <p>If Contractor:</p> <ul style="list-style-type: none"> (i) at any time makes default in proceeding with the works or any part of the work with the due diligence and continues to do so after a notice in writing of 7 days from the Employer; or (ii) commits default to complying with any of the terms and conditions of the contract and does not remedy it or take effective steps to remedy it within 7 days after a notice in writing is given to him in that behalf by the Employer; or (iii) fails to complete the works or items of work with individual dates of completion, on or before the date(s) of completion, and does not complete them within the period specified in a notice given in writing in that behalf by the Employer; or (iv) shall offer or give or agree to give to any person in Government service or to any other person of his behalf any gift or consideration of any kind as an inducement or reward for doing or forbearing to do or for having done or forborne to do any act in relation to the obtaining or execution of this or any other contract for Government; or (v) shall enter into a contract with Government in connection with which commission has been paid or agreed to be paid by him or to his knowledge, unless the particulars of any such commission and the terms of payment thereof have been previously disclosed in writing to the Accepting Authority/Employer; or (vi) shall obtain a contract with Government as a result of wrong tendering or other non-bonafide methods of competitive tendering; or (vii) being an individual, or if a firm, any partner thereof shall at any time be adjudged insolvent or have a receiving order or order for administration of his estate made against him or shall take any proceedings for liquidation or composition (other than a voluntary liquidation for the purpose of amalgamation or reconstruction) under any Insolvency Act for the time being in force or make any conveyance or assignment of his effects or composition or arrangement for the benefit of his creditors or purport so to do, or if any application be made under any Insolvency Act for the time being in force for the sequestration of his estate or if a trust deed

- (viii) be executed by him for benefit of his creditors; or being a company, shall pass a resolution or the Court shall make an order for the winding up of the company, or a receiver or manager on behalf of the debenture holders or otherwise shall be appointed or circumstances shall arise which entitle the Court or debenture holders to appoint a receiver or manager; or
- (ix) shall suffer an execution being levied on his goods and allow it to be continued for a period of 21 days; or
- (x) assigns, transfers, sublets (engagement of labour on a piece-work basis or of labour with materials not to be incorporated in the work, shall not be deemed to be subletting) or otherwise parts with or attempts to assign, transfer sublet or otherwise parts with the entire works or any portion thereof without the prior written approval of the Accepting Authority;

The Accepting Authority may, without prejudice to any other right or remedy which shall have accrued or shall accrue hereafter to Government, by a notice in writing to cancel the contract as a whole or only such item of work in default from the Contract.

The Employer shall on such cancellation by the Accepting Authority have powers to:

- (i) take possession of the site and any materials, constructional plant, implements, stores, etc., thereon; and/or
- (ii) carry out the incomplete work by any means at the risk and cost of the contractor.

On cancellation of the contract in full or in part, the Employer shall determine what amount, if any, is recoverable from the contractor for completion of the works or part of the works or in case the works or part of the works is not to be completed, the loss or damage suffered by Government. In determining the amount, credit shall be given to the contractor for the value of the work executed by him up to the time of cancellation, the value of contractor's materials taken over and incorporated in the work and use of plant and machinery belonging to the contractor.

Any excess expenditure incurred or to be incurred by Government in completing the works or part of the works or the excess loss or damages suffered or may be suffered by Government as aforesaid after allowing such credit shall without prejudice to any other right or remedy available to Government in law be recovered from any moneys due to the contractor on any account, and if such moneys are not sufficient, the contractor shall be called upon in writing and shall be liable to pay the same within 30 days.

If the contractor shall fail to pay the required sum within the aforesaid period of 30 days, the Employer shall have the right to sell any or all of the contractors' unused materials, constructional plant, implements, temporary buildings, etc. and apply the proceeds of sale thereof towards the satisfaction of any sums due from the contractor under the contract and if thereafter there be any balance outstanding from the contractor, it shall be recovered in accordance with the provisions of the contract.

Any sums in excess of the amounts due to Government and unsold materials, constructional plant, etc., shall be returned to the contractor, provided always that if cost or anticipated cost of completion by Government of the works or part of the works is less than the amount which the contractor would have been paid had he completed the works or part of the works, such benefit shall not accrue to the contractor.

8.6 Termination Of Contract After Death Of Contractor

	<p>Without prejudice to any of the rights or remedies under this contract if the Contractor dies, the Employer on behalf of the President of India shall have the option of terminating the contract without compensation to the Contractor.</p>
9.0	<p>Dispute Resolution Mechanism</p> <p>Except where otherwise provided in the contract, all questions and disputes relating to the meaning of the specifications, design, drawings and instructions here-in before mentioned and as to the quality of workmanship or materials used on the work or as to any other question, claim, right, matter or thing whatsoever in any way arising out of or relating to the contract, designs, drawings, specifications, estimates, instructions, orders or these conditions or otherwise concerning the works or the execution or failure to execute the same whether arising during the progress of the work or after the cancellation, termination, completion or abandonment thereof shall be dealt with as mentioned hereinafter:</p>
9.1	<p>Dispute Resolution Board</p> <p>If any dispute arises between the Employer and the Contractor in connection with, or arising out of, the Contract or the execution of the Works, whether during the execution of the Works or after their completion and whether before or after the repudiation or other termination of the Contract, including any disagreement by either party with any action, inaction, opinion, instruction, determination, certificate or valuation of the Engineer, the matter in dispute shall, in the first place, be referred to the dispute resolution board here in after called “the board.”</p> <p>The board shall comprise of members as defined in the bidding data. The board at its discretion may co-opt any other officer if in its opinion it may help in resolving the dispute. Either party may refer a dispute to the Board. The board shall give a decision in writing within 30 days of reference of dispute.</p> <p>Either party may refer a written decision of the board. If neither party refers the disputes to arbitration within 30 days, the board’s decision will be final and binding.</p> <p>Employer at its discretion may change any of the member of the board.</p>
9.2	<p>Arbitration</p> <p>Any dispute in respect of which the recommendation, if any, of the dispute resolution board has not become final and binding shall be finally settled in accordance with the provisions of the Arbitration and Conciliation Act, 1996 or any statutory modifications or re-enactment thereof and the rules made there under and for the time being in force. The arbitrator shall have full power to open up, review and revise any decision, and any recommendation of the conciliator related to the dispute.</p> <p>A Sole Arbitrator shall be appointed by the appointing authority as defined in contract data within 30 days of receipt of request from either party. If the arbitrator so appointed is unable or unwilling to act or resigns his appointment or vacates his office due to any reason whatsoever, another arbitrator shall be appointed in the manner aforesaid. Such person shall be entitled to proceed with same reference from the stage at which it was left by his predecessor.</p> <p>It is a term of this contract that the arbitrator shall adjudicate only such disputes as are referred to him by the appointing authority and give separate award against each dispute and claim referred to him and in all cases the arbitrator shall give reasons for the award. If</p>

	<p>any fees is payable to the arbitrator, these shall be paid equally by both the parties.</p> <p>It is also a term of the contract that the arbitrator shall be deemed to have entered on the reference on the date he issues notice to both the parties calling them to submit their statement of claims and counterstatement of claims. The venue of the arbitration shall be such place in India as may be fixed by the arbitrator in his sole discretion.</p> <p>Neither party shall be limited in the proceedings before such arbitrator to the evidence or arguments put before the conciliator for the purpose of obtaining its recommendation/decision. No recommendation shall disqualify conciliator or Employer from being called as a witness and giving evidence before the arbitrator on any matter whatsoever relevant to the dispute.</p>
9.3	<p><u>Jurisdiction of Court</u></p> <p>The Courts and High Court located within the administrative and operational area of the concerned Regional Offices shall have the sole jurisdiction for adjudication of any dispute arising out of the contract.</p>
10	<p>Miscellaneous provisions</p> <p>(i) “Nothing contained in this Contract shall be construed as establishing or creating between the Parties, a relationship of master and servant or principal and agent.</p> <p>(ii) Any failure or delay on the part of any Party to exercise right or power under this Contract shall not operate as waiver thereof.</p> <p>(iii) The Contractor/Consultant shall notify the Employer/ the Government of India of any material change in their status, in particular, where such change would impact on performance of obligations under this Contract.</p> <p>(iv) Each member/constituent of the Contractor/Consultant, in case of a consortium, shall be jointly and severally liable to and responsible for all obligations towards the Employer/Government for performance of works/services including that of its Associates/Sub Contractors under the Contract.</p> <p>(v) The Contractor/Consultant shall at all times indemnify and keep indemnified the Employer/Government of India against all claims/damages etc. for any infringement of any Intellectual Property Rights (IPR) while providing its services under the Project.</p> <p>(vi) The Contractor/Consultant shall at all times indemnify and keep indemnified the Employer/Government of India against any claims in respect of any damages or compensation payable in consequences of any accident or injury sustained or suffered by its (the Contractor’s/Consultant’s) employees or agents or by any other third Party resulting from or by any action, omission or operation conducted by or on behalf of the Contractor/Consultant.</p> <p>(vii) The Contractor/ Consultant shall at all times indemnify and keep indemnified the Employer/Government of India against any and all claims by Employees, Workman, Contractors, sub-contractors, suppliers, agent(s), employed engaged or otherwise working for the Contractor, in respect of wages, salaries, remuneration, compensation or the like.</p> <p>(viii) All claims regarding indemnity shall survive the termination or expiry of the Contract.</p> <p>(ix) It is acknowledged and agreed by all Parties that there is no representation of any type, implied or otherwise, of any absorption, regularization, continued engagement or concession or preference for employment of persons engaged by the (Contractor/Consultant) for any engagement, service or employment in any capacity in any office or establishment of the Government of India or the Employer.</p>
11	<p>Laws Governing the Contract:</p>

	This contract shall be governed by the Laws of India for the time being in force.
--	---

SECTION- IV
SPECIAL CONDITIONS
OF
CONTRACT
(SCC)

SECTION- IV			
SPECIAL CONDITIONS OF CONTRACT (SCC)			
The following Special conditions of contract shall apply for this Contract. These special conditions will modify/ substitute/ supplement the corresponding General Conditions of Contract (GCC) incorporated in Section III. The corresponding GCC clause numbers have also been indicated.			
In case of any conflict between the provision in the GCC and that in the SCC, the provision contained in the SCC shall prevail.			
S. No.	GCC Clause Number	Subject Matter	SCC Provision
1.	1.5	Signing of Contract	In addition to safety code provided in Section- XVI, the guidelines issued by Honourable Supreme Court in case No. WP(C) 36/2009 on 11.02.2010 shall be applicable for this contract.
2.	2.6	Conditions for Reimbursement of Levy/Taxes, if Levied after Receipt of Tenders	Any modification of GST by the Government the difference will be paid/ recovered to/from the contractor.
3.	3.1	Performance Guarantee	<p>1. The Contractor required submitting an initial Performance Security/ Guarantee amounting to 3% of the Contract Price within 21 days of issue of letter of Acceptance as specified in the GCC clause 3.1.</p> <p>The Performance Security shall be valid up to the stipulated date of completion of Drilling of all the PZ wells with Supply, Installation and successful Commissioning of all the DWLRs plus twelve months thereafter.</p> <p>The performance security shall be released upon fulfillment of the following conditions/ submission of following documents:-</p> <ol style="list-style-type: none"> Work Completion certificate (First One i.e. for PZ and DWLR). No Claim Certificate for the completed part of work Satisfactory completion of Defect Liability Period. Any other documents required as per contract agreement and government norms. Submitting a secondary Performance Security/ Guarantee amounting to 3% of the PART B of BOQ Contract Price (DWLR components Price)

			<p>2. The Contractor required submitting The secondary Performance Security/ Guarantee shall be 3% of the PART B of BOQ Contract Price (DWLR components Price) prior to 21 days of the expiring of initial Performance Security/ Guarantee.</p> <p>The Performance Security shall be valid up to the stipulated date of completion of performance obligations including warranty obligations and AMC period plus twelve months thereafter.</p> <p>The performance security shall be released upon fulfillment of the following conditions/ submission of following documents:-</p> <ol style="list-style-type: none"> Work Completion certificate (Second One i.e. for O&M and AMC of DWLR). No Claim Certificate for complete project. Satisfactory completion of Defect Liability Period. Any other documents required as per contract agreement and government norms <p><u>Work Completion Certificate:-</u></p> <p>There shall be two completion in this contract:-</p> <ol style="list-style-type: none"> First One:- Shall be issued after installation, testing and commissioning of PZ and DWLR as whole. Second One:- Shall be issued after completion of O&M and AMC for DWLR.
4.	3.2	Retention Money/ Security Deposit	<p>3 % (Three percent) of each running bill (periodic/ interim payment) will be withheld as Security Deposit/ retention money until final acceptance. The Security Deposit/ retention money will be release with the Final payment after issuance of Work Completion Certificate.</p>
5.	4	Execution of Work	<p>In addition to the compliance under GCC Clause 4, Scope of work, relevant technical specifications, the contractor shall extend full cooperation with CGWB to achieve the deliverables as per the best workmanship is up to the standards followed in the Industry with following QAP.</p> <p><u>Quality Assurance Plan (QAP)</u></p> <p>Following guidelines will be followed by CGWB in execution of works:-</p> <ol style="list-style-type: none"> The work will be executed through the Regional Directors and Executive Engineers of the concerned Regions and Divisions. The 'Executive Engineers will depute suitable persons not below the rank of Junior Engineer for measurement of work as per bill of quantities (BOQs) in Measurement Books in accordance with CPWD accounting system.

			<p>3. The Regional Directors will depute suitable persons for supervision of works involving scientific inputs such as assembly design, pumping tests, and collection of water samples etc. and countersign the measurements pertaining to these items and such other items which were measured during their presence.</p> <p>4. The Measurement of work will be test checked by CGWB officials/officers of respective RPMU and NPMU in following manner :-</p> <table border="1"> <thead> <tr> <th>S.No</th> <th>Designation/level of Officers/Officials</th> <th>% of Work to be test checked</th> </tr> </thead> <tbody> <tr> <td>1.</td> <td>Junior Engineer level (or above) officials/officers *Will also record measurement.</td> <td>100%</td> </tr> <tr> <td>2.</td> <td>Assistant Engineer level (or above) officers.</td> <td>30%</td> </tr> <tr> <td>3.</td> <td>Assistant Executive Engineer (or above).</td> <td>20%</td> </tr> <tr> <td>4.</td> <td>Executive Engineer/HOO of concerned Division</td> <td>10%</td> </tr> <tr> <td>5.</td> <td>Regional Director/HOO of concerned Region Office.</td> <td>5%</td> </tr> <tr> <td>6.</td> <td>Officers from NPMU</td> <td>2%</td> </tr> </tbody> </table> <p>Note: A Site Hydro geologist of concerned Region Office (AHG or above) will supervise applicable scientific component of BoQ like Assembly Design & Lowering, Pump Test ,PYT, Slug Test, Logging, Water sampling etc.</p>	S.No	Designation/level of Officers/Officials	% of Work to be test checked	1.	Junior Engineer level (or above) officials/officers *Will also record measurement.	100%	2.	Assistant Engineer level (or above) officers.	30%	3.	Assistant Executive Engineer (or above).	20%	4.	Executive Engineer/HOO of concerned Division	10%	5.	Regional Director/HOO of concerned Region Office.	5%	6.	Officers from NPMU	2%
S.No	Designation/level of Officers/Officials	% of Work to be test checked																						
1.	Junior Engineer level (or above) officials/officers *Will also record measurement.	100%																						
2.	Assistant Engineer level (or above) officers.	30%																						
3.	Assistant Executive Engineer (or above).	20%																						
4.	Executive Engineer/HOO of concerned Division	10%																						
5.	Regional Director/HOO of concerned Region Office.	5%																						
6.	Officers from NPMU	2%																						
			<p>5. The final payment for work will be made only on the personal certificate of the Executive Engineer/ Officer-In-Charge of the execution of the work in the format given below:</p> <p><i>"I, (Name of the Executive Engineer/ Officer-In-Charge), Executive Officer of (Name of the Work), am personally satisfied that the work has been executed as per the specifications laid down in the Contract Agreement and the workmanship is up to the standards followed in the Industry."</i></p>																					

			<p>The certificate will be countersigned by the concerned Regional Director.</p> <p>6. The work is to be monitored on regular basis by an Empowered Committee a Status Report has to be submitted by CGWB to MoWR, RD & GR on monthly basis, along with reasons to address the delay involved, if any.</p> <p>7. The composition of Empowered Committee(s) has been decided by the Competent Authority is as under:</p> <table border="1" data-bbox="751 592 1317 1073"> <tr> <td data-bbox="751 592 846 774">I.</td> <td data-bbox="846 592 1091 774">Member under whose administrative control the Region falls.</td> <td data-bbox="1091 592 1317 774">Chairman of the Committee</td> </tr> <tr> <td data-bbox="751 774 846 886">II.</td> <td data-bbox="846 774 1091 886">Regional Director of the concerned Region</td> <td data-bbox="1091 774 1317 886">Member</td> </tr> <tr> <td data-bbox="751 886 846 1073">II.</td> <td data-bbox="846 886 1091 1073">Superintending Engineer (to be nominated on case to case basis)</td> <td data-bbox="1091 886 1317 1073">Member</td> </tr> </table> <p>The Empowered Committee(s) shall:</p> <ul style="list-style-type: none"> — Closely monitor the progress of each work — Assess the reasons for delays, if any — Recommend condonation of delays, if it is not due to fault of the contractor. — Recommend extension of time that is beyond the power!, of Regional Director/ Member. — Ensure that the work is being executed strictly as per the conditions of the contract. <p>All matters connected with any problems/ bottlenecks in execution of work should be reported to the Chairman of the Empowered Committee.</p>	I.	Member under whose administrative control the Region falls.	Chairman of the Committee	II.	Regional Director of the concerned Region	Member	II.	Superintending Engineer (to be nominated on case to case basis)	Member
I.	Member under whose administrative control the Region falls.	Chairman of the Committee										
II.	Regional Director of the concerned Region	Member										
II.	Superintending Engineer (to be nominated on case to case basis)	Member										
			<p>8. National Project Monitoring Unit (NPMU) for monitoring and implementation of the PIB project in CGWB has been constituted. The NPMU will function under the overall Guidance and Control of Member (South). The following broad activities will be carried out by the NPMU :-</p> <ol style="list-style-type: none"> I. Develop, implement and maintain Project Management information System (MIS). II. Prepare the list of the Monitoring indicators 									

			<p>for the project</p> <ul style="list-style-type: none"> III. Prepare the packages for implementation of the activities under the project. IV. Monitor and evaluate the internal operations of the Project V. Guide the operations of the Regional Project Monitoring Unit(RPMU) through providing advice and operating as a clearing house for issues (problems and solutions) raised by the RPMU/Field units VI. Monitor status of monitoring indicators VII. Evaluate the performance of the RPMU and the field offices of CGWB VIII. Develop procedures for regular monitoring of performance of the field units of CGWB IX. Preparation of procurement documents and certify technical specifications X. Act as a support and reference point for all Project-related procurement tasks. <p>9. On lines of the NPMU, a Regional Project Monitoring Unit (RPMU) will be constituted in each of the Regional Offices where the PIB activities are proposed to be implemented. RPMU will function under the concerned Regional Director. The following major activities will be carried out by the RPMU:</p> <ul style="list-style-type: none"> I. Provide data and other inputs to NPMU for the Project Management Information System (MIS) II. Implementation of the project activities at the field level III. Monitoring and Evaluation of the internal operations of the Project and providing regular feedback to NPMU IV. Evaluate the performance of the contractors/ implementing agency and highlight the issues, if any, related to Project implementation <p>10. The progress reports concerning outsourcing works shall be sent to the Regional Director, who will coordinate with all the Empowered Committees and submit the status report to MoWR, RD & GR on monthly basis, along with reasons and remedial measures taken to address the delay involved, if any.</p>
6.	4.2	Deviations/Variations Extent and Pricing	During execution the employer reserves the right to increase or decrease the quantity of works maximum up to 20% without any change in the unit price and other terms and conditions.

			<p>The total number of wells is 810 Piezometer wells and 810 DWLR and telemetry as per BOQ. Authority to give approval for variation/deviation in items of BOQ Quantity with cost implications.</p> <table border="1"> <thead> <tr> <th>S. N.</th> <th>Authority</th> <th>Variation/ Deviation</th> </tr> </thead> <tbody> <tr> <td>1.</td> <td>Chairman, CGWB</td> <td>10 % (Subject to revised cost within the awarded value.)</td> </tr> <tr> <td>2</td> <td>DoWR, RD&GR</td> <td>Full Powers</td> </tr> </tbody> </table>	S. N.	Authority	Variation/ Deviation	1.	Chairman, CGWB	10 % (Subject to revised cost within the awarded value.)	2	DoWR, RD&GR	Full Powers
S. N.	Authority	Variation/ Deviation										
1.	Chairman, CGWB	10 % (Subject to revised cost within the awarded value.)										
2	DoWR, RD&GR	Full Powers										
7.	4.6	Employment of Technical Staff and Employees	<p>The contractor will have to employ at least one groundwater professional with minimum qualification of graduate degree in engineering/ master's degree in geosciences. Sufficient technical staff of skilled, semiskilled man power is required to be engaged in Rigs/ pump units deployed for construction of wells.</p> <p>The contractor shall provide at least one dedicated Service Engineer cum operator at the Regional Office Data Center for Operation of DWLR system and ensure seamless data transfer from remote stations to Regional & National Data Center (NDC), CGWB, Faridabad FTP server through GSM / GPRS network & from RODC to NDC & India WRIS/ WIMS software through internet. And also the processed data India WRIS/ WIMS in the form of reports/ bulletins will be transmitted to Regional & National Data Centre which should be stored in a proper manner and easy to access.</p> <p>In the event if contractor fails to employ the technical staff, recovery at the rate of Rs 2000 per day will be made from the bills submitted. In the event if contractor fails to employ the technical staff within 10 days of intimation, the employer reserves right to terminate the contract.</p> <p>Penalty for Faulty Stations/ Data Centres in respect of DWLR and Telemetry:</p> <ol style="list-style-type: none"> 1. For Remote site Rs 500/- per day (i.e per remote site) 2. For Data Centre Rs 1000/- per day 									
8.	5.1	Materials to be Provided by the Contractor	<p>Advance samples need to be submitted for approval before in use. However, no well construction materials such as pipes, screens, and gravel shall be used in construction unless inspected and approved by Engineer-In-Charge.</p>									

		Rigs to be deployed by the contractor	The rigs to be deployed by the contractor for the drilling works shall be duly registered with either Central Ground Water Authority or State Ground Water Authority and document of registration to be submitted to the concerned Executive Engineer/ Head of Office of Division before deployment of rig for the works.
9.	6	Measurement and Payment	<p>The payment in respect of Piezometer wells shall be made by Executive Engineer/ Head of Office of DivisionV, Ranchi for Bihar and Jharkhand State and Division, III, Varanasi for Uttar Pradesh State and Division XV, Kolkata for West Bengal and Division X, Bhubaneswar for Odisha in respect of wells constructed in their respective states.</p> <p>The payment of the DWLR and Telemetry, Operation and Maintenance cost for 5 years, Training cost and AMC cost shall be made by the Executive Engineer/ Head of Office Division, XV, Kolkatafor all states/ UT.</p> <p><u>Payment for the Construction of Piezometer wells</u> Payment for the Construction of Piezometer wells The payment to the contractor will be made at each milestone for completed number of wells on the basis of actual measurements / verification of Running Account (RA) bill by concerned Division's Executive Engineer/Head of Office CGWB by deducting 5% of actual measurements / verification value as Retention Money/Security Deposit . On completion of each milestone the contractor shall submit the bill along with all data and BDR in prescribed format provided in the tender document. The bill submitted by the contractor shall be supported by verified well wise works executed. The Well is treated as complete only when all items of BOQ (including pumping test if specified in BOQ, BDR etc.) as ordered by employer site representative have been carried out and completed in all aspect and well is handed over to employer. In case of non achievement of milestone, the amount equivalent to 10% of the running bill amount passed for payment by the concerned Executive Engineer will be withheld. Data generation is the essence of this contract. In respect of completed wells, the 100% payment will be released for the executed work. The necessary deductions towards non achievement of milestone, income tax, labour cess etcwill be applicable on this payment. In case of wells where compressor development has</p>

		<p>been completed but, water sample analysis and BDR are not completed due to genuine reasons duly accepted by Regional Director and all other items of BOQ as ordered by employer have been completed, the well will be treated as partially completed.</p> <p>In respect of partially completed wells, only 70% payment against executed work up to well Development shall be made subject to submission of all data pertaining to work executed. The necessary deductions towards non achievement of milestone, income tax, labour cess etc will be applicable on this payment.</p> <p>The balance payment of 30% after necessary deductions will be released after completion of remaining work like pumping test, water sample analysis and submission of BDR and their acceptance by concerned Regional Director.</p> <p><u>Release of Final Payment of PZ part</u></p> <p>After final quantities of various items of BOQ of PZ are executed, a vitiation statement shall be prepared by the concerned Executive Engineer and submitted for approval of Chairman CGWB clearly bringing out comparison of total amount of various tenderers who participated in the tender "as per finally executed quantities multiplied by itemise rates quoted by the tenderers in respect of various items of BOQ". If any vitiation in contract is found then the difference of amount between lowest cost as per vitiation statement and the total value of actual BOQ arrived based on item wise contract price, will be recovered from the final bill. Final payment shall only be released by the concerned Executive Engineer with prior approval of vitiation statement by Chairman CGWB.</p>
		<p><u>Payment for the Construction of DWLR and Telemetry</u></p> <p>a) The Bidder shall be paid 60 % of the Total Price for the Part B of the BOQ i.e for DWLR and Telemetry cost excluding AMC cost by deducting 5% amount as Retention Money/Security Deposit upon the supply, installation, testing and commissioning of the DWLR and Telemetry in the constructed Piezometers on a prorata basis for the actual executed quantities only and upon providing the requisite training as specified in the tender document.</p>

		<p>b) The Bidder shall be paid balance 40% of DWLR and Telemetry cost excluding AMC cost over the next five years @ 8% per year on half yearly basis (@4% per half year) by deducting 5% amount as Retention Money/Security Deposit The Conditions (applicable for this payment) shall be governed by Service Level Conditions as mentioned in SCC. Data generation is the essence of this contract</p> <p>c) Disbursement of Payment shall be as per the achievement of the milestones. The payment to the contractor will be made at each milestone for successfully supplied, installed, tested and commissioned DWLR with telemetry on the constructed Piezometers on the basis of actual measurements/verification done by CGWB. On completion of each milestone the contractor shall submit the bill along with all the deliverables mentioned in the tender documents in prescribed format. In case of non-achievement of milestone, the amount equivalent to 10% of the running bill amount passed for payment by the concerned Executive Engineer will be withheld.</p> <p>d) AMC cost inclusive of GST payable on it shall be paid on half yearly basis after 5 years of years of onsite manufacturer warranty period after completion of every six months by deducting 5% amount as Retention Money/Security Deposit. The Conditions (applicable for this payment) shall be governed by Service Level Conditions as mentioned in SCC.</p> <p>e) The actual Tax (GST) as applicable will be reimbursed against the valid invoice only after producing the following proof of tax amount paid to Government (i) A copy of GSTR-1, (ii) A copy of GSTR- 3B, (iii) CA certificate indicating details of invoices against which the payment under GSTR-3B has been made and any other relevant document. <u>Release of Final Payment of DWLR part</u> After final quantities of various items of BOQ of DWLR and telemetry are executed, a vitiation statement shall be prepared by the concerned Executive Engineer and submitted for approval of</p>
--	--	--

			Chairman CGWB clearly bringing out comparison of total amount of various tenderers who participated in the tender “as per finally executed quantities multiplied by itemise rates quoted by the tenderers in respect of various items of BOQ“. If any vitiation in contract is found then the difference of amount between lowest cost as per vitiation statement and the total value of actual BOQ arrived based on item wise contract price, will be recovered from the final bill. Final payment shall only be released by the concerned Executive Engineer with prior approval of vitiation statement by Chairman CGWB.
10.	6.5	Advance	Advance as per extant rule in GFR and procurement manual will be admissible.
11.		Suppliers Responsibilities for DWLR with Telemetry.	The supplier is responsible for and obliged to conduct all contracted activities in accordance with the contract using state- of- the- art methods and economic principles and exercising all means available to achieve the performance specified in the Contract. The Supplier is obliged to work closely with the Purchaser’s staff, act within its own authority and abide by directives issued by the Purchaser and implementation activities. The Supplier will abide by the job safety measures prevalent in India and will free the Purchaser from all demands or responsibilities arising from accidents or loss of life the cause of which is the supplier’s negligence. The Supplier will pay all indemnities arising from such incidents and will not holding the activities of its personnel or sub- contracted personnel and will hold itself responsible for any misbehavior /misconduct. The Supplier will treat as confidential all data and information about the purchaser, obtained in the execution of his responsibilities, in strict confidence and will not reveal such information to any other party without the prior written approval of the Purchaser.The bidder is responsible for following all Labour Laws, any other expenses applicable on the Service Engineer.
12.		Suppliers Responsibilities for DWLR with Telemetry. (Inspection and Test)	The inspections and tests shall be as detailed in Tender Document. The supplier shall get each item indicated in the Tender Document inspected in manufacturer’s works or at the premises of supplier and submit a test certificate and also manufacturer’s guarantee /warranty certificate that the items confirms to the laid down specification. The Purchaser or its representative may inspect and /or test any or all the items to confirm their conformity

			<p>to the contract specification prior to dispatch from the manufacturer's premises/ supplier's premises. Such inspection and clearance will not prejudice the right of the consignee to inspect and test the items on receipt at destination to verify conformity to technical specification.</p> <p>If the items are fails to meet the laid down specifications the supplier shall take immediate steps to remedy the deficiency or replace the defective parts of the each to the satisfaction of the purchaser/consignee.</p> <p>For validation of data, physical measurement shall be cross checked with the data generation from DWLR in presence of CGWB during installation, testing and commissioning of DWLR at destination.</p> <p>Random inspection shall be carried out by CGWB for validating the data with physical measurement during the contract period at regular interval for which arrangement for measurement shall be made by the contractor.</p> <p>The inspections and tests shall be conducted at remote site and National Data Centre, CHQ, Faridabad India as specified in Technical specification.</p>
13.		Warranty for DWLR with Telemetry	<p>Acceptance of successful installation, testing, commissioning of DWLR will be done in 4 nos. of batches (at 25%, 50%, 75% and 100% of total quantity for a State).</p> <p>The period of validity of the Warranty shall be Sixty (60) months after successful installation, testing, commissioning and acceptance. Warranty period shall be followed by 2 years comprehensive AMC. This includes seamless communication of data through telemetry system to National Data Centre, CHQ, Faridabad, India WRIS/ WIMS platform and National data center .The AMC period can be suitable extended as per mutually acceptable terms and conditions.</p> <p>After completion of contract, the equipments with accessories used for this contract Shall be handed over to the purchaser in running condition i.e. flawless data supply.</p>
14.		Warranty for DWLR with Telemetry	<p>The warranty for the Part B i.e DWLR and Telemetry shall commence from the date of installation, testing,</p>

			<p>commissioning and acceptance of the last DWLR of a batch at the constructed Piezometer</p> <p>Bidder shall provide at least one dedicated Service Engineer cum operator at the Regional office Data Center for Operation of DWLR system and ensure seamless data transfer from remote DWLR stations to National data Center through GSM/GPRS network & then to India WRIS/ WIMS software through internet. The processed data from India WRIS/ WIMS in the form of reports/ bulletins will be transmitted to Regional & National Data Centre as per technical specifications. The maximum allowed period for repair or replacement (maintenance) shall be 7 Days. It is the responsibility of the bidder to rectify/ replace the equipment without any notice from purchaser and it is the duty of its personnel i.e. dedicated service engineer cum data entry operator to notice that site become non-operational or become faulty.</p> <p>A remote site shall be treated as faulty if it fails to respond or transmits erroneous data equal to or more than 8 data measurement i.e. equal to or more than 2 transmission cycles /2 days. The decision of CGWB about errors in data shall be final and binding. If a remote site continues to remain "fail" for more than 2 days in excess of the maintenance time schedule of 7 days in a year, the contractor is liable to pay penalty @ Rs. 250/- per Day per remote site. The Day for the purpose . The Day for the purpose of penalty shall be taken as failure period of 24 hours or part thereof for a particular remote site. The amount of penalty will be recovered from performance bank guarantee or payment due to bidder during warranty period or AMC period.</p> <p>The penalty for faulty data centers beyond Maximum Response Time would be Rs 500/- per day. If the supplier fails to remedy the defect within maximum of 14 days, the purchaser may proceed to take such remedial action as may be necessary. At the suppliers risk and expense and without prejudice to any other rights which the purchaser may have against the supplier under the contract.</p>
15.		Site preparation and installation for DWLR with	<p>Site preparation and installation:</p> <p>The supplier is responsible for associated civil work required for installation and commissioning of the</p>

		Telemetry	supplies in the Schedule of Requirement under the heading of Relative services in respect of for DWLR with Telemetry
16.		Hardware installation for DWLR with Telemetry	Hardware installation: The Supplier is responsible for all unpacking, assemblies, wiring, installations, cabling between hardware units and connecting to power supplies. The Supplier will test all hardware operations and accomplish all adjustments necessary for successful and continuous operation of the hardware at all installation sites.
17.		Document to be furnished by supplier	In respect of DWLR and Telemetry, Manufactures's/ Suppliers Warranty Certificate, Certificate of Country of Origin, Inspection Certificate and Suppliers's factory inspection report. etc to be submitted .
18.		SERVICE LEVEL CONDITIONS FOR DWLR AND TELEMETRY	<p>1. The bidder is fully responsible to keep the system functional during installation, warranty and AMC period. The bidder should take suo-motu action to repair any faulty instrument and should not wait for a complaint from purchaser to initiate action</p> <p>2. DEFINITIONS</p> <p>i) REMOTE SITE</p> <p>Remote site is the site at remote location where Digital water level recorder (DWLR) systems are installed. The Remote site DWLR generally installed within the Pyrometers' headwork, dug wells (openwells), Ground water level monitoring site or any combination of these sites</p> <p>ii) DATA CENTRE</p> <p>Data centre is the respective server where data is expected to be received. In case of GSM & GPRS based telemetry, the data centre is the server installed in National data centre for receiving GSM & GPRS transmission.</p> <p>iii) INVALID DATA</p> <p>A data would be considered invalid if</p> <p>a) The value recorded / transmitted is beyond permissible limit for that variable. The valid permissible upper limits and lower limits for each monitoring variable for each site would be provided to bidder by the purchaser.</p> <p>b) If the sensor value recorded / transmitted are absurd values or sudden variation in the value (maybe within the specified limits)</p>

			<p>which is not in-line with the actual physical parameter. (e.g. If the Water level sensor recorded/ transmitted value is showing absurd sudden variation of 2mts (beyond the limits of rate of change of sensor value) with respective to the previous measurement interval, then this data is the invalid data).</p>
			<p>c) If the sensor value recorded/transmitted is having frequent/periodic gaps then the data will be considered as invalid data.</p> <p>d) If the sensor value recorded/transmitted is remain constant, even if there is variation in the physical parameters. (e.g. If the Water level recorded / transmitted value is showing constant/fix value even there is variation in the water level, then this data is the invalid data)</p> <p>e) If the sensor value recorded / transmitted is not in line with the value of co-located automatic /manual observation of the same sensor parameter.</p> <p>iv) FAILED DATA TRANSMISSION</p> <p>For each remote station, each scheduled transmission (for all variables including battery voltage) would consist of one data transmission. A data transmission would be considered failed if any of the following conditions are true</p> <ul style="list-style-type: none"> • There is no transmission of data from remote site • Data is transmitted from remote site but not received at data centre/ India WRIS/ WIMS Data is recorded in data logger but not transmitted • Data is not recorded by data logger • Battery voltage not transmitted • Only battery voltage is transmitted without any actual data from sensors • Data is transmitted but data values are invalid.
			<p>v) FAULTY STATION</p> <p>A station would be considered faulty if: In case of DWLR data received at National Data Center, if there is ≥ 8 data measurement</p>

			<p>(≥2 Transmission cycles/2days) are failed/invalid data receptions.</p> <p>vi) FAULTY DATA CENTRE</p> <p>A Data Centre shall be treated as Faulty if</p> <ul style="list-style-type: none"> • Vital Hardware Equipment's installed by bidder at Data Centre Viz. Server ,GSM modem, online3KVA UPS , FTP Server services, Firewall system etc. are not functioning properly. • Bidder has failed to pay the communication charges (SIM, internet, GSM/ GPRS etc.)& system is not in function due to unpaid communication charges. • UnauthorizedabsenceofBiddersOperatorServiceengineeratDataCentre. <p>vii) MAXIMUM RESPONSE TIME FOR REPAIR (MRTR)</p> <ul style="list-style-type: none"> • The MRTR for Remote station would be 7 days • The MRTR for Data Centre would be 2 days <p>viii) MINIMUM TIME BETWEEN REPAIRS PER STATION</p> <ul style="list-style-type: none"> • The minimum time between repairs is six months. If a station went faulty for reasons attributed to bidder and availed of MRTR once, it would not be eligible to avail the free repair period within payment period (six months) <p>2. PAYMENT FOR DATA RECEPTION</p> <ul style="list-style-type: none"> • The payment would be released proportion to data received at the Data centre. A table below presents the percentage of data reception and corresponding payment 						
			<table border="1"> <thead> <tr> <th><u>Percentage of data received</u></th> <th><u>Payment to be made to vendor</u></th> </tr> </thead> <tbody> <tr> <td>90-100%</td> <td>100 % of (4 % of DWLR and Telemetry cost excluding AMC cost)</td> </tr> <tr> <td>80-89.99%</td> <td>90 % of (4 % of DWLR and Telemetry cost excluding AMC cost)</td> </tr> </tbody> </table>	<u>Percentage of data received</u>	<u>Payment to be made to vendor</u>	90-100%	100 % of (4 % of DWLR and Telemetry cost excluding AMC cost)	80-89.99%	90 % of (4 % of DWLR and Telemetry cost excluding AMC cost)
<u>Percentage of data received</u>	<u>Payment to be made to vendor</u>								
90-100%	100 % of (4 % of DWLR and Telemetry cost excluding AMC cost)								
80-89.99%	90 % of (4 % of DWLR and Telemetry cost excluding AMC cost)								

			70-79.99%	80 % of (4 % of DWLR and Telemetry cost excluding AMC cost)
			60-69.99%	70 % of (4 % of DWLR and Telemetry cost excluding AMC cost)
			50-59.99%	60 % of (4 % of DWLR and Telemetry cost excluding AMC cost)
			40-49.99%	40 % of (4 % of DWLR and Telemetry cost excluding AMC cost)
			30-39.99%	25 % of (4 % of DWLR and Telemetry cost excluding AMC cost)
			Below30%	NIL
		<p>The calculations for data reception percent age are as below</p> <p>Data reception percentage for each station= $[1-(\text{No of Failed transmissions}/\text{No of transmissions expected})]*100$</p> <p>Data reception percentage for each station is calculated for payment period(sixmonths)</p> <p>Number of transmissions expected is calculated based on transmission cycle. For 6-hourly transmission cycle, if there are 182 days in six months period,</p> <p>The no. of expected transmissions=$182(\text{days}) * 4(\text{transmissions per day})$ for a given station.</p> <p>If a station went faulty during payment period of six months and availed of free time of MRTR (7 days), the 7 days period would be subtracted from no. of expected transmissions. For example, if a station went faulty and payment period is for 182 days, the number of transmissions expected would be calculated as:</p> <p>Number of transmissions expected = $(182-7) * 4$; here 7 days time to repair. However, this deduction would be allowed only once in six months period for any given station.</p>		

			<p style="text-align: center;">Total data Reception percentage =</p> $\frac{\sum_{i=1}^n \text{Data reception percentage of } i^{\text{th}} \text{ station}}{n}$ <p>Where n is number of remote stations</p> <p>In case the percentage of data reception is below 50% continuously for 3 months, the Purchaser may initiate termination process as per Tender Conditions</p>
19.	8.0	Operation Contract of	<p>Milestone/ Deliverables/Period of completion The total Time period for the completion of this Package shall be 660 days as below:</p> <p>(A) For Construction of the Piezometer Wells Milestone is as follows: Total number of wells should be completed on or before 570 days from the date of issue of Work Order by the The Supertending Engineer, Central Ground Water Board, Bhujal Bhawan, NH-IV, Faridabad, 121001. The well will be treated as complete only when all the ordered items of BOQ including pumping tests if specified in the BOQ (i.e. items as ordered by CGWB representative as per site condition for each well) are complete including submission of item wise data and BDR. Against each milestone, the cumulative progress of works in percentage (i.e. number of wells in percentage) to be achieved and amount to be withheld (in percentage) in case of non -achievement against each milestone are furnished in the table given below. In case the bidder accelerate the cumulative progress of work and completes the work within stipulated period, the withheld amount if any will be released without any interest</p> <p>In case of wells where pumping test (if specified in BOQ), water sample analysis and BDR are not completed due to genuine reasons duly accepted by Regional Director and all other items of BOQ including well development as ordered by employer have been completed, the well will be treated as partially completed. The partially completed wells will not be counted for milestone i.e, for cumulative progress of work. Only completed wells in all respect will be counted for milestone.</p> <p>In case the contractor does not achieve a particular milestone mentioned the percentage/ amount</p>

			<p>shown against that milestone shall be withheld, to be adjusted against the compensation levied at the final grant of extension of time. Withholding of this amount on failure to achieve a milestone, shall be without any notice to the contractor. However, if the contractor catches up with the progress of work on the subsequent milestone(s), the withheld amount shall be released. In case the contractor fails to make up for the delay in the subsequent milestone(s), percentage/ amount mentioned against each milestone missed subsequently also shall be withheld. No interest, whatsoever, shall be payable on such withheld amount.</p>																																						
			<table border="1" data-bbox="721 716 1295 1423"> <thead> <tr> <th data-bbox="721 716 786 898">Milestone</th> <th data-bbox="786 716 915 898">Time since award of work (in days)</th> <th data-bbox="915 716 1089 898">Cumulative progress of works(i.e. number of wells) to be completed</th> <th data-bbox="1089 716 1295 898">Amount to be withheld in case of non-achievement of milestone</th> </tr> </thead> <tbody> <tr> <td data-bbox="721 898 786 947">1</td> <td data-bbox="786 898 915 947">60</td> <td data-bbox="915 898 1089 947">5%</td> <td data-bbox="1089 898 1295 1423" rowspan="11">10% of the running bill amount passed for payment by the concerned Executive Engineer.</td> </tr> <tr> <td data-bbox="721 947 786 995">2</td> <td data-bbox="786 947 915 995">90</td> <td data-bbox="915 947 1089 995">10%</td> </tr> <tr> <td data-bbox="721 995 786 1043">3</td> <td data-bbox="786 995 915 1043">120</td> <td data-bbox="915 995 1089 1043">20%</td> </tr> <tr> <td data-bbox="721 1043 786 1092">4</td> <td data-bbox="786 1043 915 1092">150</td> <td data-bbox="915 1043 1089 1092">30%</td> </tr> <tr> <td data-bbox="721 1092 786 1140">5</td> <td data-bbox="786 1092 915 1140">210</td> <td data-bbox="915 1092 1089 1140">40%</td> </tr> <tr> <td data-bbox="721 1140 786 1188">6</td> <td data-bbox="786 1140 915 1188">270</td> <td data-bbox="915 1140 1089 1188">50%</td> </tr> <tr> <td data-bbox="721 1188 786 1236">7</td> <td data-bbox="786 1188 915 1236">330</td> <td data-bbox="915 1188 1089 1236">60%</td> </tr> <tr> <td data-bbox="721 1236 786 1285">8</td> <td data-bbox="786 1236 915 1285">390</td> <td data-bbox="915 1236 1089 1285">70%</td> </tr> <tr> <td data-bbox="721 1285 786 1333">9</td> <td data-bbox="786 1285 915 1333">450</td> <td data-bbox="915 1285 1089 1333">80%</td> </tr> <tr> <td data-bbox="721 1333 786 1381">10</td> <td data-bbox="786 1333 915 1381">510</td> <td data-bbox="915 1333 1089 1381">90%</td> </tr> <tr> <td data-bbox="721 1381 786 1423">11</td> <td data-bbox="786 1381 915 1423">570</td> <td data-bbox="915 1381 1089 1423">100%</td> </tr> </tbody> </table> <p data-bbox="721 1465 1352 1606">In case, the contractor completes the Work before the milestone deadline, then he shall be paid by the employer upon submission of bills irrespective of the milestone deadline.</p>	Milestone	Time since award of work (in days)	Cumulative progress of works(i.e. number of wells) to be completed	Amount to be withheld in case of non-achievement of milestone	1	60	5%	10% of the running bill amount passed for payment by the concerned Executive Engineer.	2	90	10%	3	120	20%	4	150	30%	5	210	40%	6	270	50%	7	330	60%	8	390	70%	9	450	80%	10	510	90%	11	570	100%
Milestone	Time since award of work (in days)	Cumulative progress of works(i.e. number of wells) to be completed	Amount to be withheld in case of non-achievement of milestone																																						
1	60	5%	10% of the running bill amount passed for payment by the concerned Executive Engineer.																																						
2	90	10%																																							
3	120	20%																																							
4	150	30%																																							
5	210	40%																																							
6	270	50%																																							
7	330	60%																																							
8	390	70%																																							
9	450	80%																																							
10	510	90%																																							
11	570	100%																																							

B) For Supply, Commissioning, Installation and Training of DWLR with telemetry.

Milestone is as follows: Total number of DWLR and telemetry including the supply, commissioning, installation and training should be completed on or before 660 days from the date of issue of Work Order by the The Supertending Engineer, Central Ground Water Board, Bhujal Bhawan, NH-IV, Faridabad, 121001.

Milestone	Time since award of work (in days)	Cumulative progress of works(i.e. number of DWLR's installed, commissioned alongwith training) to be completed	Amount to be withheld in case of non-achievement of milestone
1	240	25%	10% of the running bill amount passed for payment by the concerned Executive Engineer.
2	360	50%	
3	540	75%	
4	660	100%	

The running bill as per above milestone shall be raised and then submitted to the Regional Director of the concerned RODC where server and other accessories are installed for verification

Upon verification of the above, the payment will be released by the Executive Engineer under the jurisdiction of Concerned Regional Director of the RODC.

1st (First) Milestone shall only be considered achieved when 25 % of DWLR with telemetry are installed and data alongwith other deliverables as per the tender document are successfully received and validated by the Regional Director of the concerned RODC.

In case, the contractor completes the Work before the milestone deadline, then he shall be paid by the employer upon submission of bills irrespective of the milestone deadline.

			In case the contractor does not achieve a particular milestone mentioned the percentage/ amount shown against that milestone shall be withheld, to be adjusted against the compensation levied at the final grant of extension of time. Withholding of this amount on failure to achieve a milestone, shall be without any notice to the contractor. However, if the contractor catches up with the progress of work on the subsequent milestone(s), the withheld amount shall be released. In case the contractor fails to make up for the delay in the subsequent milestone(s), percentage/ amount mentioned against each milestone missed subsequently also shall be withheld. No interest, whatsoever, shall be payable on such withheld amount
20.	8.2	Compensation for Delay	Liquidated damage as per G.C.C 8.2 shall be applicable.
21.	9.1	Dispute Resolution Board	The Dispute Resolution Board shall comprise i) The concerned Member, CGWB under whose jurisdiction the work is being executed ii) The FAO, CGWB iii) The Regional Director, CGWB of the concerned region/s . iv) The Superintending Engineer, CGWB under concerned Member
22.	9.2	Arbitration	The Chairman, CGWB shall appoint the Arbitrator. In case of any dispute, it will be settled within the jurisdiction of Faridabad, Haryana.
23.	11	Laws Governing the Contract:	In addition to existing conditions in G.C.C, the contractor shall assist the employer throughout continuation of contract in respect of all matters arising out of contract, serve all notices and obtain all consents, approval and permission on behalf of employer required to be taken under any regulation and by laws of the local or other authority which shall be applicable to work.

SECTION- V

SCOPE OF WORK AND TECHNICAL SPECIFICATIONS

SECTION-V – PART A- SOFT ROCK

SCOPE OF WORK AND TECHNICAL SPECIFICATIONS

1	General <p>The locations for construction of wells provided in the section- VII are tentative. The contractor on award of work shall confirm the locations from concerned Regional Director, CGWB before deputing manpower and machinery for undertaking the work. In case work could not be carried out at a particular site due to a genuine reason like non approachability, land dispute, etc. alternate site will be provided.</p> <p>The Contractor shall have to furnish in writing to the concerned Regional Director & Executive Engineer, CGWB, a programme of drilling of wells within a week of handing over the pin pointed sites to the Contractor.</p> <p>The location/sites furnished are tentative. The Employer reserves the right to modify or change the location as well as the depth of construction as per the local prevailing conditions and no additional cost will be paid in this regard.</p> <p>For the purpose of drilling, approach road, water for drilling, crew, camp and other infrastructure, preparation of the site and placing the rig etc, are to be arranged by the drilling contractor at his own cost. At each site, a tent with furniture should be provided to facilitate the CGWB representative to discharge his duties.</p> <p>No payment shall be made against shifting of rig unit with accessories for construction of Piezometers</p> <p>Technical problems during drilling like jamming of drill string, damages to drilling tool, stoppage of work due to unforeseen reasons etc would be the responsibility of the drilling contractor and no compensation of any kind would be paid by the department. In case the well could not be completed and had to be abandoned due to contractor's fault, no payment will be made for that well. In case the well is abandoned due to geological condition such as poor discharge, inadequate depth of good quality water bearing formation, etc, duly certified by representative of CGWB and on approval of Regional Director, payment for executed works will be made. The decision of Regional Director/Executive Engineer will be binding on contractors in deciding whether the well is abandoned due to contractor's fault or due to hydro geological conditions.</p> <p>Drilling Fluid (Bentonite Mud fluid) required for drilling and for efficient removal of cuttings to reach the targeted depth and saving borehole from collapsing will be the responsibility of the contractor.</p>
2	Scope of Work and Overview
2.1	Scope of Work <p>The scope involves drilling of pilot hole, collection of samples for preparation of lithology,, electrical logging(SP, Resistivity & Natural Gamma), preparation of composite log, design</p>

	<p>of well assembly, enlargement of hole size by reaming, lowering of well assembly, gravel shrouding, cement sealing, clay packing, development, pumping test and data analysis, collection of water samples for chemical analysis, chemical analysis of water sample and preparation of Basic Data Report .</p> <p>The details of all the activities to be carried out by the contractor including methodology to be adopted and reporting formats are discussed in this section Sl. No 3.0 to 17.0.</p> <p>The contractor should deploy minimum _____ Nos of Rig unit attached with pump unit [No of rig unit to be calculated based on formula given below:</p> $R = (W \times D) / T$ <p>Where, R is the minimum number of Rig unit required W is the total No of wells D is the average number of days required to complete one well (i.e. D= 3 in case of 200m well in Hard rock and D = 20 in case of 300m well in soft rock) And T is the scheduled time period for completion of the project in days]</p>
<p>3.</p>	<p>Construction of Piezometer Wells</p> <p>The number of Peizometer wells to be constructed is given in Section VI. Tentative locations of Peizometer wells is given in section VII. The employer reserves the right to change the location in case of non availability of site clearance or any other reasons and no additional cost will be paid for change in locations.</p> <p>For Piezometer drilling of pilot hole of 216 mm(8 ½”) by RR/ Drag bit using Bentonite drilling fluid shall be carried out. The targeted depth of pilot hole is as per BOQ , however it may vary from about 100 m to 305m or as specified in the BOQ depending upon geology.</p> <p>Formation strata samples should be collected after proper washing adopting standard procedure for sample collection for every 3 m or in the event of change in formation.</p> <p>Electrical logging and natural gamma logging as specified in BOQ shall be carried out upto bottom of pilot hole. Logging Report alongwith Zone wise water quality shall be submitted. In case the logging could not be completed to desired depth in 8 ½” pilot hole after repeated attempts, logging in larger dia hole may be allowed by site hydrogeologist and no additional payment will be made for enlargement of hole for logging purpose and for additional attempts of logging.</p> <p>The depth of blank pipe and slotted pipe with bail plug (well assembly) will be decided by the employer’s site Hydro Geologist/representative of Regional Director, according to the formation encountered during drilling. The depth of well assembly may vary from 100 m to 300m or as per BOQ</p> <p>The bill of quantity should contain only final reamed size of the Piezometer wells and its depth and hence rate should be quoted for final reamed size and its depth only i.e. the final reamed rate deemed to cover the intermediate reaming sizes. The reaming with intermediate sizes should not be included in the bill of quantity.</p>

	<p>As per recommendation of assembly chart, casing pipe/slotted pipe as mentioned in this section Sl. No 5 should be lowered. After assembly lowering, back washing should be carried out.</p> <p>Gravel shrouding should be carried out as mentioned in this section Sl. No 7.</p> <p>Cement Sealing and Clay packing shall be provided as mentioned in this section Sl.No 8.</p> <p>Well development should be carried out as mentioned in this section Sl. No 10.</p> <p>Analysis of sample as per BOQ shall be carried out by Contractor from NABL accredited lab and shall be submitted to the Regional Director, CGWB, Concerned Region. One set of sample (Basic and heavy metal) from Piezometer shall be submitted to the Regional Director, CGWB, Concerned Region ..</p>
<p>4</p>	<p>Methodology / Approach</p>
<p>4.1</p>	<p>Process /Methodology Involved In Construction Of Wells In Soft Rock Up To 300 M Depth</p> <p>Piezometer Wells</p> <ul style="list-style-type: none"> (i) Site selection and pinpointing of site (ii) Shifting of Rig (iii) Site preparation (iv) Pilot hole drilling [using 216mm (8½")diameter RR Bit/ Drag Bit] as per BOQ (v) Sample collection & preparation of litholog (vi) Bore hole logging (Resistivity,SP,Natural Gamma) (vii) Preparation of E log Report including Zone wise quality (viii) Preparation of Composite log using data of (v) & (vi) above (ix) Designing of Well assembly (x) Reaming of Bore hole (by using appropriate size of RR bits based on recommended well assembly size, giving a margin for minimum 100mm thickness for gravel packing) as per BOQ (xi) Lowering of well assembly (xii) Back washing, shrouding of gravel and Clay packing (cement sealing, if required). Cement sealing should be done by tremie pipe. Adequate rest shall be provided after cement sealing. Clay balls should be used clay packing. (xiii) Verticality test of well(if required) (xiv) Zone wise Development of well by air compressor, overpumpingor by any other means till the water is clear and sand free (xv) Pumping Test if specified in BOQ <ul style="list-style-type: none"> a. Water sample collection for analysis of Basic & Heavy metals under guidance of CGWB site Hydrogeologist/ Chemist. (xvi) Construction of platform, well capping and installation of protection box

	<p>(xvii) Preparation of Basic Data Report & submission</p> <p>(xviii) Clearance of site and bringing it to original natural condition</p> <p>(xix) Handing over of well</p>
4.2	Deleted
5	<p>Well Assembly</p> <p>(i) M.S Casing pipes used for well assembly should confirm to the specification given below.</p> <p>(a) BIS marked steel tubes plain ended with bevelled edges on both ends, for water wells of type ERW conforming to Table No 3 of IS: 4270/2001 (third revision). The steel for the ERW casing pipes shall be of Make Tata, Jindal, SAIL, Essar and test certificate of material from Tata/Jindal/SAIL/Essar shall mandatorily be submitted to the Engineer-Incharge at the time of Inspection.</p> <p>(ii) <i>LCG V-wire screen pipe with slot opening as mentioned in BOQ should confirm to latest version of IS:8110-2000. Test certificate of OEM mandatorily be submitted to the concerned Executive Engineer at the time of Inspection. The material should be inspected and approved by the concerned Executive Engineer or his representative before lowering. Random lab test shall be carried out by the EE or his rep. for Diameter of Screen, Slot Size, Collapse Strength, Tensile Strength, Weld joint strength, ID, OD and Thickness. (Cost of test shall be borne by the Contractor).</i></p> <p>(iii) A length of 0.50 m of casing pipe should be left above the ground level.</p> <p>(iv) Well cap should be securely sealed to the pipe after tube well is checked by the Engineer-In-Charge.</p>
6	<p>Data Collection</p> <p>Drilling contractor will</p> <p>(i) Maintain a drill time log for every 3 m for wells drilled or in the event of change in formation in soft rock formations.</p> <p>(ii) Collect formation samples of minimum 500g mass at an interval of 3m or change of formation during drilling and properly pack in polythene bags and label with date/ depth/ location.</p> <p>(iii) Carry out geophysical logging (SP, Resistivity & Natural Gamma)</p> <p>(iv) Measure discharge over 90° V notch plate during development of well.</p> <p>(v) Collect 1 litre water sample after development is complete and during test for wells drilled in soft rock formations in good quality polypropylene bottles using standard procedures for basic analysis and heavy metals. Two sample (one for basic parameters and one for heavy metals) or as specified in BOQ</p> <p>Necessary arrangements are to be made for verification by Engineer-In-Charge/ CGWB site Hydrogeologist for checking of depth of borehole, length of casing, static water level, discharge and any other requirement as shall be felt necessary from time to time. A guest tent should be pitched at the site during drilling/ testing and provided with table and chairs for the Site Hydrogeologist/ Engineer-In-Charge.</p>
7	Gravel Packing of Tubewell

	<p>After the well assembly has been placed in position, the Pea gravel as per specification mentioned in BOQ has to be shrouded in the annular space between the well assembly pipe and the borehole by adopting reverse fluid circulation method upto the depth as mentioned in assembly chart recommendation. The gravel should be of rounded to sub-rounded shape and shall be supplied by the Contractor. Before shrouding, the pea gravel must be got inspected and approved by CGWB site representative. Sufficient care should be taken so that gravel packing is proper and no bridging takes place during gravel shrouding. If necessary, in case of bridging of gravel, air compressor of appropriate capacity should be used for proper gravel shrouding as per instruction of employer's site representative for which no additional cost will be paid. After gravel packing, sounding should be carried out to ascertain the correct depth of gravel packing. As a cross check, the theoretical annular volume of gravel packing and volume of actual gravel consumed should be compared to ascertain that gravel shrouding is without bridging. In case of EW the gravel packing shall be measured in meters from the bottom of Reamed depth or from Assembly depth+ 5 m, which ever is less. In case of OW, gravel pack shall be measured from bottom depth of hole or from Assembly depth+ 5 m, which ever is less. If gravel packing is not carried out properly, no payment will be made till rectification.</p>
8	<p>Cement Sealing and clay packing of Tube Well: After Gravel shrouding is done cement sealing (if required) shall be done using tremie pipe. Cement sealing of 5 m thickness shall be provided. Before cement sealing 1 m thick clay shall be provided above gravel. Adequate rest (minimum 10 hrs) shall be provided after cement sealing. Annular space between borehole and pipe above cement seal (if provided) shall be filled with clay balls. If cement sealing is not provided clay packing shall be provided above gravels.</p>
9	<p>Verticality Test The vertical test shall be carried out in wells where pump/eduction pipe cannot be lowered smoothly to the desired depth and the contractor shall carry out the vertical test at his cost as per the decision of the Employer side representative. The well assembly shall be placed vertically inside the borehole. Verticality test as per IS: 2800 (Part 2) -1979 must be arranged by the Contractor with standard equipment at his cost. In case of deviation beyond the permissible limit, the well will be treated as vertically out. The acceptance of suitability of the well will be purely at the discretion of CGWB. The well will not be accepted in case pump could not be lowered to desired depth due to non-verticality of well and no payment will be made.</p>
10	<p>Well Development Zone wise development of wells shall be carried out by air compressor of appropriate capacity i.e. minimum 1723.69 KPa(250 Psi) and minimum 21.23 cubic meter per minute (750 cfm) immediately after construction within 5 days of construction of well. Subsequently well should be developed by over pumping by VT/Submersible pump or by any other means till the water is free from mud and fine sand. In case development is not carried out in time resulting in poor yield or in case the well is not properly developed, no payment will be made till recification is carried out.</p>
11	<p>Construction of Platform and installation of Well Cap, Protection Box and Display BOARD After completion of well in all aspects, the well should be provided with well cap using MS</p>

	<p>plate of minimum thickness 6mm and protection box made of minimum 3.00 mm GI sheets with Brass lock (7 lever) with all common keys (One Key for multiple locks) preferably Make: Godrej/Harrison/Link with three individual keys for each well.</p> <p>A concrete platform using concrete mix of 1:2:4 should be provided around the well pipe welded with minimum 6 No's of 38mm (1 ½") L angle as per the drawing specification given in the tender. Schematic diagram of well is given in section IX.</p> <p>A Display Board as per drawing in the section IX with details of wells should be installed near the well. On completion of well, the site around the well should be brought to previous natural condition</p>
12	<p>Successful and Unsuccessful Well</p> <p>Success of well will be decided by the Representative of Regional Director. In case of non-availability of minimum thickness of aquifer capable of yielding expected discharge, the bore hole may be abandoned and payment based on actual work carried out will be made at quoted rates. The well abandonment committee will be constituted by respective Regional Director and will consist of two officers of hydrogeological discipline and one officer of engineering discipline to decide upon the measurement of unsuccessful well. If the well is abandoned due to the fault of the contractor or due to the limitations of the machinery, borehole fishing etc, no payment shall be made.</p>
13	<p>Mode of Measurement</p> <p>The Contractor shall be paid on actual Computerised Measurement Books (CMB) of finished work on the basis of quoted rates. The Contractor shall be eligible for payment of full length drilling of pilot hole irrespective of the design of tube well assembly provided the more drilling necessitated in search of a suitable aquifer and as per the advice of Engineer-In-Charge.</p>
14	<p>The Surrounding Area After Well Completion</p> <p>The area surrounding the well site has to be levelled, pits to be filled and the area to be restored to the original condition i.e. as before start of drilling operation.</p>
15	<p>Handing Over of Tubewell</p> <p>The well must be properly handed over to the CGWB along with hard and soft copy of BDR in triplicate. The wells will be treated as completed and handed over only on submission of Basic Data report along with all data, analysis, Graph sheet etc (Hard copy in triplicate & soft copy) and upon the installation of DWLR and telemetry systems, duly accepted by the Regional Director, CGWB, Concerned Region. The copy of the accepted BDR and related document, if any, is to be submitted to concerned Executive Engineer for payment purpose.</p>
16	<p>Monitoring and Measurement of Work</p>
16.1	<p>The monitoring and measurement of different activities for PIEZOMETER drilling shall be as specified in below table</p>

S. No.	Parameter	Monitoring Mechanism / Measurement Criteria
1)	Location of site	Site selection report(s) duly signed by the representatives of contractor, state government and regional office CGWB.
2)	a)Depth/ Diameter of pilot hole in Piezometer	Sounding should be carried out in the presence of the Engineer-In-Charge. In wells wherever logging is conducted, the logged depth will be taken as pilot hole depth in case of variation between pilot hole depth and logging depth.
	b) Depth of reaming	Depth of reaming shall be assembly depth plus 5m or actual which ever is less.
3)	Inspection of assembly pipes, screen pipes, gravel etc. as per specification	Pipes used for assembly, screen pipes, gravel etc. should be pre-inspected and approved by Engineer-In-Charge. Assembly lowering should be carried out in the presence of CGWB Hydro geologist/Engineer-in- Charge. On completion of gravel shrouding sounding should be carried out before cement sealing and it should be ensured that gravel shrouding and cement sealing are in correct depth.
4)	Litholog/ Electrical log/ Composite log/ Well Design	Verification/ validation by the Regional office
5)	Installation of well assembly and gravel shrouding	Should be carried out in the presence of Engineer-In-Charge/CGWB site Hydro geologist.
6)	Development of well	Development should be carried out in the presence of CGWB site Hydro geologist/Engineer-in Charge. Sand content of water will be verified by CGWB site Hydro geologist/Engineer-In-Charge.
7)	Testing of well	PYT and Slug test (if specified in the BOQ) should be carried out by the contractor in the presence of CGWB Hydro geologist/Engineer- In-Charge. Analysis and evaluation report to be prepared by the contractor and to be validated by the Regional office.
8)	Well capping/ construction of platform and installation of protection box	Physical inspection by the Engineer- In-Charge
9)	Supply , Installation and Commissioning of DWLR and Telemetry	Physical Inspection by the Engineer- In-Charge and data generation report
	PS: The contractor will report to the Engineer-In-Charge via e-mail/phone the daily progress at each site and submit status report on weekly basis to Executive Engineer.	

<p>18</p>	<p>Preparation and Submission of BDR</p> <p>The contractor is required to prepare the basic data report (BDR) for the wells as per the format provided in Section-VIII. The BDR along with litholog, logging data, test data, graph sheet, analysis report shall be submitted to CGWB in soft as well as hard copy (in triplicate). In site where more than one well is constructed, one BDR should be prepared for all the wells constructed in the site and the litholog, well diagram, time log, static water level etc for EW and OW should be furnished separately in the BDR.</p>
<p>19</p>	<p>Specification and Drawings</p> <p>The specifications for drilling and construction of wells shall be as specified in the bill of quantities. The drawings for Well cap, Protection Box, Cement concrete platform, Display Board and Display Board platform is provided in Section- IX.</p>

SECTION-V – PART B- HARD ROCK

SCOPE OF WORK AND TECHNICAL SPECIFICATIONS

1 General

The locations for construction of wells provided in the section- VII are tentative. The contractor on award of work shall confirm the locations from concerned Regional Director, CGWB before deputing manpower and machinery for undertaking the work. In case work could not be carried out at a particular site due to a genuine reason like non approachability, land dispute, etc. alternate site will be provided.

The Contractor shall have to furnish in writing to the concerned Regional Director & Executive Engineer, CGWB, a programme of drilling of wells within a week of handing over the pin pointed sites to the Contractor.

The location/sites furnished are tentative. The Employer reserves the right to modify or change the location as well as the depth of construction as per the local prevailing conditions and no additional cost will be paid in this regard.

For the purpose of drilling approach road, water for drilling, crew, camp and other infrastructure, preparation of the site and placing the rig at the site etc., are to be arranged by the drilling contractor at his own cost. At each site, a tent with furniture should be provided to facilitate the CGWB representative to discharge his duties

Technical problems during drilling like jamming of drill string, damages to drilling tool, stoppage of work due to unforeseen reasons etc would be the responsibility of the drilling contractor and no compensation of any kind would be paid by the department. In case the well could not be completed and had to be abandoned due to contractor's fault, no payment will be made for that well. In case the well is abandoned due to geological condition such as poor discharge, inadequate depth of good quality water bearing formation, etc, duly certified by representative of CGWB and on approval of Regional Director, payment for executed works will be made. The decision of Regional Director/Executive Engineer will be binding on contractors in deciding whether the well is abandoned due to contractor's fault or due to hydro geological conditions

2 Scope of Work and Overview

2.1 Scope of Work

The scope involves drilling and casing of overburden, drilling in hard rock up to the targeted depth, identification of depth of each fracture, assessment of yield after encountering of each fracture, development and testing of Piezometers Wells if specified in BOQ , collection of lithlog samples and water samples, chemical analysis of water samples, preparation of lithology and preparation of Basic Data report.

The contractor shall be required to carry out drilling and construction of Piezometer Wells as per tender, development by air compressor and conducting preliminary yield of wells, , slug test and data analysis if specified in BOQ, preparation of basic data reports

along with site location map, and submission to CGWB in prescribed format (section-VIII &IX) in triplicate along with well diagram in details of reaming diameter, well size and depth, cement sealing depth if any, clay packing depth etc.

The details of all the activities to be carried out by the contractor including methodology to be adopted and reporting formats are discussed in following section 3.0 to 17.0. Tentative list of locations has been provided in section-VI.

The contractor should deploy minimum _____ Nos of Rig unit attached with pump unit
[No of rig unit to be calculated based on formula given below:

$$R = (W \times D) / T$$

Where,

R is the minimum number of Rig unit required

W is the total No of wells

D is the average number of days required to complete one well (i.e. D= 3 in case of 200m well in Hard rock and D = 20 in case of 300m well in soft rock)

And T is the scheduled time period for completion of the project in days]

3. Construction of Piezometer Wells

It is proposed to construct Piezometer well for 200m or depth as specified in BOQ.).

Tentative locations of Piezometer wells are given in **section VII**. The employer reserves the right to change the location in case of non availability of site clearance or any other reasons and no additional cost will be paid for change in locations

The number of Piezometer well to be constructed shown in Section- VI.

Water sample should be collected in 1litre HDPE bottles using standard procedures as specified in the BOQ. BDR along with litholog, logging data and report, test data and report etc. along with well diagram incorporating all details should be submitted. On completion of well, the site should be brought to the previous natural condition.

The well should be provided with well cap using MS plate of minimum thickness 6mm and protection box made of **3.00 mm** GI sheets with Brass lock (7 lever) with all common keys (One Key for multiple locks) preferably Make: Godrej/Harrison/Link with three individual keys for each well. A concrete platform (using concrete mix of 1:2:4) as per drawing should be provided around the well housing pipe as per the specification given in the tender.

The Engineer in charge will decide the actual casing length at site based on overburden encountered. Lithologs samples should be collected after proper washing adopting standard procedure for sample collection for every 3m or in the event of change in formation.

Also Preliminary Yield Test (PYT) should be conducted if specified in the BOQ or if required as per instruction of site officer on encountering each fracture with substantial discharge. For conducting PYT, 75mm diameter M.S Pipe (Eduction pipe) up to 1m above bottom level of drilling and 25mm dia airline should be lowered inside eduction pipe up to approximately 1m above bottom level of eduction pipe or the air line should be

placed in eduction pipe so that the discharge is optimum. 20mm MS/ PVC pipe should be lowered for measuring water level. Slug test has to be conducted on need based or if specified in BOQ, on instruction of site geologist. The proper jigs and fixture or anchoring of pipes during the test... Water sample should be collected during pumping test and during drilling in 1 litre HDPE bottles and handed over to the Regional Director with receipt. The nomenclature should be made on the bottle to identify the site where the water is collected. BDR along with litho log, logging data and report, test data and report, water sample analysis report etc should be submitted. Also well diagram with details such as overburden drilling diameter and its depth, casing pipe lowered and its diameter and depth, naked bore diameter, depth at which fractures encountered, static water level, V notch discharge on encountering each fractures and depth, its size and depth clay packing, cement sealing if required, concrete platform etc should be submitted. The well should be provided with well cap using M.S plate of minimum thickness 6mm and protection box as per drawing. A concrete platform should be provided around the well housing pipe welded with minimum 6 Nos. of anchoring plateausas per the drawing specification given in the tender. Schematic diagram of well is given in section-IX. On completion of well, the site around the well should be brought to previous natural condition.

4 Methodology / Approach

4.1 Process/ Methodology Involved In Construction Of Wells In Hard Rock Up To 300/200 M Depth

Piezometer Wells

- i)** Site selection and pinpointing of site.
- ii)** Shifting of Rig (shortest approachable route)
- iii)** Site preparation
- iv)** Overburden drilling (using Button Bit/RR Bit)
- v)** Installation of casing pipe in the overburden and surface grouting.
- vi)** Telescopic Drilling using DTH method up to targeted depth
- vii)** Measurement of yield using V notch/volumetric method after encountering each fracture zone and simultaneous water sample collection and quality analysis for individual fracture zone
- viii)** Sample collection and preparation of litholog
- ix)** PYT/Slug test (need based if specified in BOQ)
- x)** Development by air compressor

- xi)** Verticality test of well if required.
- xii)** Water sample collection
- xiii)** Construction of platform, well capping and installation of protection box.
- xiv)** Preparation of Basic Data Report
- xv)** Handing over of well

5 Casing

- (i) M.S Casing pipes used for well assembly should confirm to the specification given below.
 - (a) BIS marked steel tubes plain ended with bevelled edges on both ends, for water wells of type ERW conforming to Table No 3 of IS: 4270/2001 (third revision). The steel for the ERW casing pipes shall be of Make Tata, Jindal, SAIL, Essar and test certificate of material from Tata/Jindal/SAIL/Essar shall mandatorily be submitted to the Engineer-Incharge at the time of Inspection.
- (ii) *LCG V-wire screen pipe with slot opening as mentioned in BOQ should confirm to latest version of IS:8110-2000. Test certificate of OEM mandatorily be submitted to the concerned Executive Engineer at the time of Inspection. The material should be inspected and approved by the concerned Executive Engineer or his representative before lowering. Random lab test shall be carried out by the EE or his rep. for Diameter of Screen, Slot Size, Collapse Strength, Tensile Strength, Weld joint strength, ID, OD and Thickness. (Cost of test shall be borne by the Contractor).*
- (iii) M.S Casing pipes as specified in above should confirm to the specification given below.
- (iv) BIS marked steel tubes plain ended for water wells of type ERW conforming to Table No 3 of IS:4270/2001 (third revision).
- (v) A length of 0.50 m of casing pipe should be left above the ground level.
- (vi) MS Casing pipe should be installed perfectly vertical on the consolidated rock basement in such a manner that there should not be leakage of air during drilling. The annular space between the casing and the borehole wall should be grouted with cement slurry to avoid entry of local foreign material in the borehole in consolidated formations.
- (vii) Well cap should be securely sealed to the pipe after bore hole is checked by the Engineer-In-Charge. The well cap should be fabricated as per the provided specifications by CGWB.

6 Well Development

In respect of borehole drilled in hard rock formations, well should be washed/ developed using compressor thoroughly after completion of the drilling operation till clear water comes.

7 Construction of Platform, Well Cap, Protection Box and Display BOARD

After the completion of well in all respects described above, the contractor shall fabricate

and install well cap using MS plate of minimum thickness 6mm, make platform around well, and install Display Board and Protection Box as described in the Drawings in section-IX

8 Data Collection

Drilling contractor will

- i. Maintain a drill time log for every meter of drilling for wells drilled in hard rock formation.
- ii. Measure discharge over 90° V notch plate during drilling on every increase/decrease of yield at various depths for wells drilled in hard rock formations.
- iii. Collect formation samples of minimum 500 g mass at an interval of 3m or change of formation during drilling and properly pack in polythene bags and label with date/ depth/ location.
- iv. Collect 1 litre water sample for every water-bearing zone encountered for wells drilled in hard rock formations.

Necessary arrangements are to be made for verification by Engineer-In-Charge for checking of depth of borehole, length of casing, static water level, discharge and any other requirement as shall be felt necessary from time to time. A guest tent should be pitched at the site during drilling/ testing and provided with table and chairs for the Engineer-In-Charge.

9 Verticality Test

If required, the vertical test shall be carried out in wells where pump/eduction pipe cannot be lowered smoothly to the desired depth and the contractor shall carry out the vertical test at his cost as per the decision of the Employer side representative. The well assembly shall be placed vertically inside the borehole. Verticality test as per IS: 2800 (Part 2) -1979 must be arranged by the Contractor with standard equipment at his cost. In case of deviation beyond the permissible limit, the well will be treated as vertically out. The acceptance of suitability of the well will be purely at the discretion of CGWB. The well will not be accepted in case pump could not be lowered to desired depth due to non-verticality of well and no payment will be made.

10 Successful and Unsuccessful Well

Success of well will be decided by the Employer authorized officer. In case of non-availability of minimum thickness of aquifer capable of yielding expected discharge, the bore hole may be abandoned and payment based on actual work carried out will be made at quoted rates. The tube well abandonment committee will be constituted by respective Regional Director and will consist of two officers of hydrogeological discipline and one officer of engineering discipline to decide upon the measurement of unsuccessful well. If the well is abandoned due to the fault of the contractor or due to the limitations of the machinery, borehole fishing etc, **no payment shall be made.**

11 Submission of reports in the prescribed formats

The following reports are required to be submitted by the contractor in the format prescribed in relevant Annexure in hard as well as soft copies:

- (i) Litholog
- (ii) PYT and Slug test (if specified in BOQ) Data as per proforma
- (iii) Logging data as per proforma and analysis
- (iv) Water sample chemical analysis report.
- (v) Consolidated statement of test (As per proforma in section VIII)
- (vi) BDR as per proforma enclosed in section VIII

12 Preliminary yield Test (PYT) if specified in BoQ

The contractor has to carry out the PYT as per instruction of employer site representative in order to determine aquifer parameter (Transmissivity, Specific capacity)

12.1 Methodology/Approach

Transmissivity may be determined by conducting Preliminary Yield Test in wellshaving discharge around 1 lps to 1.5 lps or based on hydrogeological condition, as per the instruction of employer site representative.

Method/Procedure:

- (i) For conducting PYT, 75mm dia or higher dia GI/ MS/ (Eductor pipe) upto 1m above bottom level of drilling and 25mm dia airline should be lowered inside eduction pipe up to 1m above bottom level of eductor pipe or the air line should be placed in such a way that the discharge of water is optimum. 20 mm GI/ MS/ PVC pipe should be lowered for measuring water level and using water level sounders, the water level should be measured.
- (ii) Pre pumping water level is to be measured in the pumping well.
- (iii) The well is to be pumped at a constant discharge for long duration (100 min) and water level during recuperation (recovery) should be are measured periodically (Section-VIII). The discharge should be measured using 90° V Notch
- (iv) Recovery water level is to be recorded as per data sheet (Section-VIII) after stopping the pump until the pumped water level reaches static water level or 90% of the static water level.

The data recorded shall be analysed by using Jacob straight line method.

13 Slug Test (if specified in BoQ)

The contractor shall conduct slug test in piezometers (if specified in BOQ) as and when required by the employer.

13.1 Methodology/ Approach

Slug tests is to be conducted in wells as per the decision of employer, where conventional aquifer performance tests cannot be conducted due to constraints of yield. In this method, a known volume or Slug of water (maximum 20 litre) is instantaneously injected into the well and the water level is measured at periodic intervals till the pre-injection water level returns to the pre-injection level or for a pre-determined period, whichever is less.

Procedure for conducting slug test:

- (i) Collect and record all available information (depth, diameter, yield, aquifer type, lithology etc.) about the tube well / bore well to be tested
- (ii) Measure the static water level before the injection of slug.
- (iii) Inject a known volume (slug) of water (not more than 20 litres) into the bore well/tube well.
- (iv) Measure the water level at closely spaced intervals (once every minute up to 10 minutes, once every 2 minutes up to 20 minutes and then on once every 5 minutes till completion).
- (v) Continue recording depth/time measurements until the water level returns to pre-injection level or a sufficient number of readings have been made to clearly show a trend on a plot of water level recovery versus the logarithm of time.
- (vi) Estimate the value of change in head (H_0) in response to injection of slug (H_0). Compute also the change in water levels (H) for each subsequent measurement.
- (vii) Compute the values of H/H_0 for each measurement.

Analysis of Data

Field data generated need to be analysed using standard methods

- (i) For Unconfined aquifer - Hvorslev method (1951)/Bouwer and Rice method (1976).
- (ii) For confined aquifers - Cooper et al (1967) method

13.2 Technical Specifications

- (i) Slug test is to be conducted in Piezometers (only if specified in BOQ)
- (ii) Conducting test with slug injection (20 litres)
- (iii) Slug injected should be of potable water quality.
- (iv) Recording water level data in periodic time steps (minute recording upto 10 min, 2 minute recordings upto 20 minutes and then on 5 minute recordings till completion)

Analysis of data generated using following method for unconfined aquifer by

- (i) Hvorslev method(1951) and
- (ii) Bouwer and Rice method (1976)

For Confined aquifer by - Cooper et al (1967)

Submission of report in prescribed format (Hard and Soft copy) containing

- (i) Site location details – (Section-VI)
- (ii) raw data sheet - (Section-VIII)
- (iii) Processed graph sheet
- (iv) Calculation details and results
- (v) Consolidated statement of slug test (Section-VIII)

14 Mode of Measurement

The Contractor shall be paid on actual Computerised Measurement Books (CMB) of finished work on the basis of quoted rates. The Contractor shall be eligible for payment of full length drilling of bore hole.

15 The Surrounding Area After Well Completion

The area surrounding the well site has to be levelled, pits to be filled and the area to be restored to the original condition i.e. as before start of drilling operation.

16 Handing Over of well

The tube/bore well must be properly handed over to the CGWB along with hard and soft copy of BDR in triplicate. The wells will be treated as completed and handed over only on submission of Basic Data report along with all data, analysis, Graph sheet etc (Hard copy in triplicate & soft copy) and upon the installation of DWLR and telemetry systems duly accepted by the concerned Regional Director, CGWB. The copy of the accepted BDR and related document, if any, is to be submitted to Executive Engineer for payment purpose

17 Monitoring and Measurement of Work :

- 17.1 The monitoring and measurement of different activities for PIEZOMETER drilling shall be as specified in below table

S. No.	Parameter	Monitoring Mechanism / Measurement Criteria
1)	Location of site	Site selection report(s) duly signed by the representatives of contractor, state government and regional office CGWB.
2)	Depth/ Diameter of pilot hole	Sounding should be carried out in the presence of the Engineer-In-Charge. In wells wherever logging is conducted, the log depth will be taken as pilot depth in

		case of variation between pilot hole depth and logging depth for payment purpose.
3)	Litholog/ Electrical log/ Composite log/Well Design	Verification/ validation by the Regional office.
4)	Development of well	Should be carried out in the presence of Engineer-In-Charge/Regional office site hydro geologist.
5)	Testing of well	PYT and Slug test (if specified in BOQ) wherever applicable should be carried out by the contractor in the presence of Engineer- In-Charge. Analysis and evaluation report to be prepared by the contractor and to be validated by the Regional office
6)	Well capping/ construction of platform and installation of protection box	Physical inspection by the Engineer- In-Charge
7)	Supply , Installation and Commissioning of DWLR and Telemetry	Physcial Inspection by the Engineer- In-Charge and data generation report

PS: The contractor will report to the Engineer-In-Charge via e-mail/phone the daily progress at each site and submit status report on weekly basis to Executive Engineer.

18.2 Preparation and Submission of BDR

The contractor is required to prepare the basic data report (BDR) for the wells as per the format provided in Section-VIII. The BDR along with data,graph sheet,analysis report for each of the well shall be submitted to CGWB in soft as well as hard copy (in triplicate). In site where more than one well is constructed, one BDR should be prepared for all the Piezometers constructed in the site.The litholog, well diagram, time log, static water leveletc for the Piuezometers should be furnished seperately in the BDR.

18.3 Specification and Drawings

The specifications for drilling and construction of wells shall be as specified in the bill of quantities. The drawings for Display Board and Display Board platform is provided in Section-IX.

SECTION-V – PART C-

Supply, Installation, Commissioning of DWLRs and telemetry, Establishment of Data Acquisition system & its maintenance for Real Time Ground Water Level monitoring and supply of Ground water level, ground water temperature data from site and receipt of data at National Data Centre, CHQ, Faridabad, in a desired format from Nos CONSTRUCTED Piezometers wells Through telemetry systems with 05 years warranty and 02 years AMC

SCOPE OF WORK AND TECHNICAL SPECIFICATIONS

SCOPE OF WORK AND TECHNICAL SPECIFICATIONS

TECHNICAL SPECIFICATIONS WITHOUT QUALITY PROBE

1.0 SCOPE OF WORK

- (i) Complete supply, installation, testing, commissioning of remote stations including associated civil works, sensors, data logger, software, hardware and ancillaries' equipment, etc.
- (ii) Clean well to be ensured by the contractor before lowering the instrument and its accessories.
- (iii) The scope of work also includes supply of data during Five (5) years comprehensive warranty period and two (2) years AMC period to commence immediately after the expiry of warranty period.
- (iv) Technical design, supply, installation, testing, commissioning of Digital Water Level Recorder(DWLR) for the real time ground water level data collection network and establish data communications using **GSM & GPRS telemetry** between the remote stations and existing National data centre, CGWB, Faridabad and through the India WRIS/ WIMS at NewDelhi. This includes, but is not limited to acquiring service, and maintaining all aspects of the service during the Comprehensive warranty period.
- (v) Establish communication between remote DWLR stations with existing GSM & GPRS receiving system along with all required arrangement at National Data Centre, CHQ, Faridabad to collect GSM & GPRS data from DWLR station network. And required all acquiring hardware and software, installation, configuration. The data is to be submitted in the requisite format and hence no data processing software has to be provided by the bidder at National data centre
- (vi) Perform on-site assembly, start-up of the supplied goods.
- (vii) Complete commissioning integration, testing & organization of the whole system.
- (viii) Provide operation & maintenance services during Five (5) years comprehensive warranty period and two (2) years AMC period to commence immediately after the expiry of warranty period, which shall include all components at the remote DWLR stations as well as all newly acquired equipment's in the existing data center. The **AMC** must be comprehensive without any exclusion except from force majeure will be permitted.
- (ix) Provide installation and maintenance reports as required by the Purchaser and any delay is not acceptable in time schedule provided by supplier.
- (x) Supply detailed operation and maintenance manual for each component in the system and compile Knowledge and working supply type Manual for training purpose (including multimedia training kits).
- (xi) Provide classroom and field training to the sufficient number of **CGWB** personnel on the DWLR data acquisition system. This includes operation and maintenance procedures. Training will also occur at selected field locations as selected by the Purchaser.
- (xii) A guarantee by the manufacturer that all equipment being provided will be supported for a minimum of ten years after the commissioning of the Digital Water Level Recorder (DWLR) Systems.
- (xiii) Calibration and validation of the installed system shall continue during the entire **Warranty** period on half yearly basis.
- (xiv) The remote stations shall store the data for at least one year.
- (xv) Supply a detailed operation and maintenance manual for each appropriate unit of supplied goods.
- (xvi) Security of installed equipment's against theft and vandalism will be the responsibility of the Bidder till successful installation, commissioning, and successful site acceptance testing.
- (xvii) Although all accessories and fixtures required for installation of the equipment & their specifications have been

specified in technical specifications however, bidder shall ensure the satisfactory performance & functioning of DWLR system complete, for this if any accessory or items are required that shall be provided by bidder, the cost towards that is deemed to be included in the cost tendered by the bidder, no extra cost shall be paid to the bidder on this account.

- (xviii) Ensure that all software licenses and maintenance agreements are in the name of Purchaser and should seek full support and updates for such software for the duration of the warranty period and Annual Maintenance Services Period. All the software licenses should be valid for the design life of the system that is 10 years from date of commissioning.
- (xix) The DWLR shall be certified preferably from BIS / IS or other renowned National / International (Developed Nations) testing and certification institutions or the satisfactory performance certificate for performance of Hydrostatic Pressure based DWLR and telemetry from Government organization to which these items were provided shall be furnished. The make of the DWLR and the above certifications shall mandatorily be submitted along with the Bid document and also to the Engineer-Incharge at the time of Inspection during the execution of the contract.

The batteries and other external items in the DWLR system accessories shall be BIS/IS certified (Certificate Required) or of reputed make. These items shall be replaced by the contractor due to any un-serviceability during O&M period without any cost to CGWB..

2.0 Technical Specifications of Equipment

The Goods and Related Services shall comply with following Technical Specifications and Standards:

(A) Specifications of the DWLR, hydrostatic Type (GW) with Telemetry System Specifications for Water Level and Temperature sensor

Feature	Value
Site Conditions	
Ambient Temperature	From 0 to 60 °C
Humidity	5-100%
Altitude	0-2500 meter
DWLR Water Level Sensor with Temperature Sensor	
Sensor Type	Submersible pressure transducer with Non-Vented Pressure Sensor with Barometric Pressure Correction for Individual Sensor
Range	(30m, 60m, 120m, 200m, 300m)
Installation Depth (Cable length)	Tentative depth as per the attached list. Concerned Regional Director will decide the depth of installation at the time of drilling of piezometer
Dimension	Outer dia meter of sensor unit: <80mm,(for sensor)
Material	Stainless Steel (SS-316) or other better corrosion resistant material
Ingress Protection	IP 68 for sensor
Accuracy	0.2% FSO

Resolution	3mm
Reproducibility	0.1% full scale or better
Long Term Stability	0.1% Full scale and should ensure long term stability without any field calibration requirements except barometric compensation
Temperature Measuring Range	0 to 50°C
Temperature Measuring Accuracy	Better than $\pm 0.3^\circ\text{C}$
Burst Pressure	≥ 2 Time Full scale
Overload Pressure	1.5 Time full scale without effect on calibration
Over-voltage Protection on supply & sensor wires	Should include lightening, over-voltage and surge protection
Out put	SDI-12,RS-485,4-20mA or compatible with data logger.
Installation	The system should be provided with a suspension bracket, Wellen closure / canopy & junction boxes (if required) allowing secure installation within the Piezometers' headwork, including appropriate cable mounting accessories to allow the sensor to be adjusted to the required depth.
Direct Read Sensor Cable	<p>The cable shall have following features:</p> <ul style="list-style-type: none"> • Strength members for good longitudinal stability of cable • The cable and contacts should be fixed or quick connect • Cable screen to be connected to the data logger ground terminal to minimize electrical interference. • A cable suspension bracket allowing the DWLR to be adjusted to the required depth in a stable and reproducible manner. • Corrosion and moisture free as the equipment has to work under water condition. • Cable should have good flexibility. • Should be of Polyurethane Jacket or better • The electrical wires shall have sufficient conductivity to allow for extension of the cable to up to 200m without degrading accuracy, stability and data communication. • In case of Single Cable, No PVC pipe is needed. However if there is more than one Cable, 25mm dia PVC pipe with BIS mark should be provided for housing the cables to avoid tangling.
Data logger	
Atmospheric Pressure correction	Atmospheric Pressure corrections to be made automatically

Data Logger Input	Level sensor*, Temperature sensor * only compensated water levels need to be transmitted to data base, however barometric pressure/uncompensated water levels may be stored in data logger and shall be transferred to the data base periodically.
Resolution of Measurement	16-bit ADC with +/- 1 LSB accuracy
Measuring interval and measuring modes	Should be programmed to store data from 1 minute one reading to 24 hours one reading.
Settling up Time	<30 minutes
Recording Capacity	Shall store data of at least 1 year
Memory Type	Non-Volatile flash memory that can store one year of data (with 15 minute logging interval) & expandable up to minimum 1GB using USB/SD Card
Power Supply	Should be equipped with lithium/alkaline/SMF battery pack giving at least 2 years operation (with one transmission and four recordings per day). Battery must be replaceable in the field or in local offices of the implementing Agency or supplier. Replacement of batteries must be readily available in India.
Battery Voltage Monitoring	Monitoring and transmission of Battery Voltage level
Data logger Location	Data logger should be located on top (on ground surface).
Built in clock	Accuracy to ± 1 minute per year
Displayed Time Resolution	1 second or better
Over-voltage Protection on supply & sensor wires	Should include lightning over-voltage and surge protection
Protection	IP68 with Impact Resistant for Water level sensor IP65 (for data logger) with Impact Resistant
Port for configuration	One serial port for communication with laptop for programming
Ports for telemetry	Port for communication with GSM & GPRS telemetry
Operating System	Windows based software for system configuration/communication
Licenses	All required licenses shall be included
Real time clock	Time synchronization facility shall be provided with IST
Accessories	Serial cable and adaptor if required along with all accessories and fixing units etc.

Communication Interface	
Computer Interface	The Logger must be capable of connection to a computer via USB 2.0/ USB 3.0 and supply should include the necessary interface cables.
File Format	The format of the data downloaded by communication interface shall be in standard CSV format (as specified in technical Specifications) which is compatible with India WRIS/ WIMS software.
GSM & GPRS Transmitter	
Transmission System	GSM / GPRS/ edge-based data transmission system
Frequency range	900 MHz:824-960 MHz / 1800MHz:1710-1880 MHz 4G and better
Performance	Data Reception availability of 95 % or better
Communication Direction	Utilize GPRS network for two-way connection with connection with FTP,TCP/IP(INTERNET) connection and SMS server
Transmission trigger	Data collection to be triggered by interrogation from DataC enter,or by event-based transmission triggered by remote site
Power Saving	Ability to disable interrogation system in order to save power at remote site
Communication Protocol	Data transmission to execute HTTP Post or FTP,SMS to transmit data to the Data Center
Accessories	All associated equipment,including Antenna all cables and mounting hardware
Software for Data logger	
Operating System	Windows based software for system configuration transfer and analysis of data to computer
Version	English language version
License	All required licenses included
General Features	
Battery	The battery should be easy to replace, and easily available in the market.
Tools	Complete tool kit for installation and routine maintenance
Manuals	Full documentation and maintenance instructions in English
---Training	As per mutual consent at the time of installation of telemetry system

Specifications for Data Services

Bidder is to acquire, manage, and operate data collection, storage and dissemination to support the following activities during 5 years warranty period and 2 years comprehensive AMC period or DWLRs with telemetry system.

Note: A server and storage system for additional backup shall be provided at National Data Center

S.No.	Parameter	Functionality requirement
1	Data collection performance	<p>Bidder should be seamless data and responsible for</p> <ul style="list-style-type: none"> □ Real-time data collection at all DWLR stations & shall ensure seamless data transfer. □ The data from DWLR stations will be transmitted through GSM / GPRS in the standard CSV format (as specified in technical Specifications) to FTP server at National Data Center (NDC), Faridabad and India WRIS/ WIMS. □ Data Transfer to NDC server & India WRIS/ WIMS software through internet. This data will be processed and disseminated via India WRIS/ WIMS cloud. □ The processed data from India WRIS/ WIMS in the form of reports/ bulletins will be transmitted to existing National Data Centre.
2	Data maintenance	All activities pertaining to installation, data services, Operation & maintenance at the remote DWLR station will be maintained by the bidder during the warranty and maintenance period and will include a log of activities during every station visit.
3	Reports & Bulletins Storage system	Storage of all data, reports & bulletins in the proper manner and easy to access. This data will be backed up in such a way that it is not possible to lose data that has already been stored with the use of mirrored or replicated storage in such a way that no data is lost.
4	Help desk	Bidder to operate help desk to respond to queries from the purchaser. Help desk will be able to solve any problems related to data collection, processing, and dissemination to the purchaser. Help desk shall be available from 8am to 6pm, Monday–Sat.

4.0 Specifications for Data Transmission System (Telemetry)

The transmission system should be tightly integrated with the DWLR System (DAS), along with compact remote / field mounted systems consisting of sensor, data logger, modem and antenna.

- (i) The system should be water tight (IP 68 for sensor & IP65 for data logger or equivalent) and impact resistant;
- (ii) The system should allow easy access for monitoring measurements without removing complete system.
- (iii) System must be power-supplied by standard lithium / alkaline batteries for operation time of at least, **Two years** by one set of batteries (one transmission per day, 4 measurements per day) and must be Placed in a water resistant (IP 65 or equivalent) enclosure. The replacement of batteries during **five years** warranty would be responsibility of the bidder, **at bidder's cost**.

- (iv) The system must have integrated energy management system using free programmable time slots for measurement and transmission to minimize power consumption;
- (v) The connectors should be water-tight (IP68 or equivalent).
- (vi) An alarm notification must be sent by the system via SMS to user defined phone numbers through suitable means of communication for user defined parameters. This includes battery performance (battery voltage).
- (vii) Standard USB / RS232 communication interface should be available for set up and configuration and must be easily accessible.
- (viii) Data logger shall be provided with Atmospheric Pressure sensor at individual station, & Atmospheric Pressure correction shall applied automatically on the raw water level reading from non-vented water level sensor. The details of correction procedure shall be fully documented in user manual. Provision shall be made to view and store the raw and compensated water level data along with atmospheric pressure and Water Temperature data in data logger memory.

Only compensated water level need to transmit to data base, however barometric pressure / uncompensated water levels may be stored in data logger and shall be transferred to the data base periodically.
- (ix) All measurement and set up options, data download and programming of data logger shall also be done by online session similar to all functions at site by direct connection to a PC.
- (x) Data download / retrieval from remote DWLR station to central server PC via GSM & GPRS network shall be provided. The data from remote station should be in standard CSV format (as specified in technical Specifications) which is compatible with India WRIS/ WIMS software
- (xi) The software should be provided to allow download of the data from the DWLR data logger to a Laptop / hand held devices in the field. The downloaded data shall be in standard CSV format (as specified in technical specifications) which is compatible with India WRIS/ WIMS software.

5.0 Specifications for Data Processing Hardware at Data Centre

The Bidder shall provide one high end server with monitor and 3KVA online UPS with power backup of 4 hour and one computer node (workstation) at the Data Center along with A3 size color printer & 42" LED display. All the consumables (including batteries) except cartridge and papers shall be responsibility of the Bidder during the entire period of warranty and AMC. The minimum specifications of server, computer node, Display system areas below:

Hardware at National Data Centre, CHQ, Faridabad should have following major equipment;

- a) Server with monitor as per the following specifications
- b) Necessary data switch, router and fire wall for minimum 8 Mbps internet speed, static IP
- c) 3 KVA online UPS with 4 hours backup time
- d) Computer Node (Workstation) PC
- e) A 3 Size color Printer
- f) 42" LED Display unit

5.1 Server Technical Specification:

- a) Server having two nos. of x 8664-bit processor (Intel Xeon E5-2620 v 4 or better)
- b) 64 GB DDR III expandable to 256 GB or more
- c) Integrated Graphics Controller
- d) SASRAID Controller supporting RAID0,1,
- e) 2*600GB SAS Hot Swap HDD (10 K or higher RPM),
- f) Dual 1 Gbps Network port,

- g) DVD writer,
- h) 23" LED Monitor with a resolution 1920 X 1080 or better,
- i) OEM Keyboard and OEM Mouse
- j) Server Chassis having Redundant Hot Swappable Power Supply with 8 Hot Swap drive bays,
- k) Certification for Linux and Windows,
- l) All required device drivers for System Configuration and Server Management Support including additional data storage facility of 8 TB for 5 years and all accessories.
- m) Software: Perpetual license for window server (2012 or later) ,perpetual license for MS Office, firewall system with Good antivirus etc.

5.2 Computer Node (Work station)

Operating system	Windows10 Home / Professional
Chipset	Intel H270 and above or equivalent
Processor	Intel®Core™i7-6700T with Intel ®HD Graphics 530 (2.8GHz, upto 3.6GHz,8 MB cache, 4cores) and above or equivalent
Memory	8 GB DDR3Lr and above or equivalent (RAM)
Hard drive description	1 TB 7200rpm SATA or better
Display	58.42cm(23) diagonal WLED- back lit (1920x1080). Touch-enabled (optional)
Optical drive	DVD-Writer
Network interface	Integrated 10 /100/ 1000 Gigabit Ethernet LAN
Wireless	802.11b/g/n(1x1)andBluetooth®4.0combo(Optional)
Port	4 USB 2.0;2 USB 3.0;1 head phone / microphone combo
Pointing device	USB wired / wireless optical mouse
Key board	USB wired / wireless standard key board
Pre-installed software	Preinstalled MSOffice Life time with Good antivirus is preferred.

5.3 Printers Specifications

A 3 size color printer shall be procured for National Data Center from a reputed manufacturer.

- i. A3 color printer
- ii. Functions: Print, Copy, Scan
- iii. Printing Upto 20 page / minute
- iv. Black & color printing: As fast as 9.5 sec per page
- v. Recommended monthly page volume: 250 to 2000
- vi. Processor speed: 600 MHz
- vii. Connectivity: e-Print capability
- viii. Paper handling input, standard:100 sheet input tray
- ix) Paper handling output, standard: 100-sheet face-down bin

5.4 DISPLAY UNIT (LED)

- i) Screen Type: 42" Screen LED
- ii) Display resolution:1920x1080
- iii) Colors: 256 K colors
- iv) Interfaces: 1x Ethernet (RJ45) (max.12Mbit/s), HDMI port, USBport1x USB, Multimedia card / SD card slot combined.
- iv) Industrial Ethernet: 1x Ethernet (RJ45)
- v) Protocols: Protocol (Ethernet) TCP / IP
- vi) Image formats Supported: JPEG,JPS,MPO
- v)Sound technology: Dolby digital

6.0 Transmission of Data format to RODC, NDC, Faridabad & India WRIS/ WIMS Software: The format

for GSM / GPRS communication nis as specified below

Table below gives the GSM /GPRS data parameters and their identification code format which is required to transmit the data from data logger to FTP server.

FORMAT:

& Station ID, Date and Time, Mobile Number, Battery, Water Temp, Corrected Water Level

Above data string will be ended with New-Line character and a separated at a string will be for each measurement cycle.

Example Data Spring:

& 738 D1E76,07/01/1900: 00,9849556430,13.5,22.3,26.347

& 738 D1E76,07/01/1906: 00,9849556430,13.5,24.5,26.347

& 738 D1E76,07/01/1912: 00,9849556430,13.5,26.8,26.347

& 738 D1E76,07/01/1918: 00,9849556430,13.5,24.3,26.347

SI.No.	Channel no.	Parameter
1.	Station ID	Start of String should be '&' and Eight Characters Station ID provider by bidder
2.	Date and Time	Measurement date and Time in DD/MM/YYHH: MMin IST of the measurement cycle
3.	Mobile Number	Mobile no (10 digit) of remote station SIM
4.	Battery	Battery voltage in Volts with1 right digital measurement date and time
5.	Water Temp	Water Temperature in °C with1 right digitat Measurement date and time
6.	Corrected Water Level	Water level after atmospheric pressure compensation in Mts. With 3 right digitat measurement date and time

Note:

1. If any sensor is not connected then it should transmit '--' characters in place of the sensor value.
2. Attached format is indicative, recommended for standardized data acquisition for development of unified Water Information System.

7.0 TRAINING AND DOCUMENTATION

The Bidder is required to provide an extensive training programme for the system. The training set forth in the following paragraphs is a minimum requirement and the bidder should propose any additional training that he considers critical for long term success of the system operations.

The Bidder is expected to provide an outline or table indicating the contents of each of the required courses. The table shall describe the specific topics to be covered for each day of the training period.

The Bidder is responsible for the salaries of the training instructors and all training materials. The costs of travel, transportation and per diem for the trainees shall be borne by the Purchaser.

Training shall be provided by the bidder in several phases. The training shall include both class room and field trainings and will be continued during all five years. The bidder is required to have DWLR equipmentspecialists.

7.1 The Bidder shall provide mandatory trainings as training modules as part of the Tender given as under:

S. No.	Description	Numbers of trainings	Number of Participants per session
1	Two types of trainings are to be organised. (i) Onsite training to be organised in each State where DWLRs are to be installed. Three onsite trainings for each State (ii) Training at concerned Regional Office Data Center (RODC) of CGWB. Two trainings at concerned RODC.	As specified in BOQ	15

All aspects of the electrical, instrumentation and telemetry equipment being supplied shall be covered in the courses and full documentation shall be provided. The documentation and kits shall be got approved from purchaser in advance. The course shall provide detail documentation and shall ensure that the purchaser's personnel shall be able to modify settings/parameters without reference back to the Supplier. The places /sites where this training will be decided later by the purchaser.

The training course will take place as decided by the Purchaser. In case of formal training, the Purchaser will provide classroom and other logistics. The Bidder will facilitate the professional and the training material. On-the-job training will be provided by the Bidder in conjunction with the installation of the DWLRs and during the course of maintenance as required.

7.2 TA / DA of the trainees shall be borne by the purchaser.

7.3 Training kit containing course material in soft as well as hard copy shall be provided by the Bidder.

7.4 All logistical arrangement such as projector, training space etc. for training is to be made by purchaser

8.0 PREVENTIVE MAINTENANCE

The bidder shall be responsible for operation and maintenance of all stations /components of installations, commissioning, site acceptance and operation tests. All equipment maintenance cost, repairs, replacements and repairs to civil work shall be borne by the bidder during the warranty AMC Period. The scope of O&M support would include all materials and services including major replacement of components, mandatory spare parts required to ensure smooth and sustainable operations of the entire system. The bidder shall provide monthly maintenance reports during the course of maintenance. The bidder shall supply a Manual specifying all the faults experienced by the system together with an account of how such faults have been rectified. Bidder shall provide the list of mandatory spare parts & shall ensure the availability of sufficient mandatory spare parts in its godown for fulfilling its service obligations during warranty and AMC period. The same can be inspected by Engineer-in Charge or its authorized representative.

The bidders shall ensure the following visits at remote site for preventive maintenance .The bidder should take time stamped geo tagged photographs of the equipment during each maintenance visit (either scheduled or unscheduled visit). The photographs should show the condition of equipment before maintenance, during maintenance and after maintenance.

SCHEDULE SHOWING FREQUENCY OF SCHEDULED VISITS FOR ROUTINE AND PREVENTIVE MAINTENANCE

Sl.No.	Station Category	Minimum Annual Preventive Visits	Remarks
1	Data Server maintenance	4	Every Quarter and also on need basis
2	DWLR stations	4	Every Quarter and also on need basis

8.1 Operation & Maintenance

- Bidder shall provide at least one dedicated Service Engineer cum operator at the Regional Office Data Center for Operation of DWLR system and ensure seamless data transfer from remote stations to Regional & National Data Center (NDC), CGWB, Faridabad FTP server through GSM / GPRS network & from RODC to NDC & India WRIS/ WIMS software through internet. And also the processed data from India WRIS/ WIMS in the form of reports/ bulletins will be transmitted to Regional & National Data Centre which should be stored in a proper manner and easy to access.
- Operation and Maintenance shall include free of cost repairs/ replacement of hardware and Software necessary to keep the system functional for the period of five years from Date of Installation and further during 2 years of AMC.

TECHNICAL RESPONSIVENESS FORM

Bidder shall furnish clause by clause commentary against the laid down technical specification and standards as per the format given below:

(A) Summary of Instructions

- (i) Particulars of Manufacturer and local agent cum representative are to be given under rows Model and Address.
- (ii) All entry boxes in column **"Specification and Standards as offered in by Bidder"** shall be filled-in accurately and comprehensively. Quantitative fields shall be filled in accurately. It is not acceptable to use 'Yes', No, Compliant or similar evading words. Following format is designed to help the Bidder to understand the requirements of the equipment being procured. The Bidder must describe in the format how his bid responds to the technical requirements of the equipment. Bidder to note that one or two word responses (e.g. "Yes", "No" "will comply" or similar evading words) are normally not sufficient to confirm the responsiveness with the technical requirements, hence elaborate responses are sought from the bidders. **In case deviation on the following technical requirements of equipment is not as per the minimum criteria mentioned, the bids may be declared "non-responsive"**.
- (iii) Requested materials and information shall be enclosed with the bid and be unambiguously associated with instruments as offered in the bid
- (iv) Negligence to comply with the instructions and requirements as stated above makes the bid liable to be rejected.
- (v) Abbreviations: OD-Outer Diameter; ID-Inner Diameter; FS-Full Scale; Pa-Pascal (unit of pressure), DWLR-Digital Water Level Recorder; DRS-Data Retrieval System; HHT-Hand Held Terminal, DCP-Data Collection Platform, AWLR-Automatic Water Level Recorder
- (vi) Sample interval is the interval at which samples or sensor readings are taken. The recording /measurement interval defines the interval at which the data records are stored in memory. A data record can represent a single sample or the average of a number of samples. In particular the result of the wave suppression filter is a single record representing the average value of a number of samples.

B) Entries requiring special attention:

- (i) The longitudinal properties of the suspension cable affect the accuracy directly. Bidder to specify all factors affecting the longitudinal properties of the suspension cable: e.g. length creeps due to sensor and cable weight (submerged) longitudinal temperature coefficient, uncoiling after installation, expansion /contraction of jack due to temperature and aging, etc.

(C) Bidder shall provide information in the formats given below:

(i) Make /Model/ Local Agent etc.:

Bidder	DWLR Sensor Make / model	Data Logger make/ model	Local Agent
Name / Complete Address/ Website/ Email	Model: Manufacturer: Name: Place: Tel: Fax: E-mail: Web:	Model: Manufacturer: Name: Place: Tel: Fax: E-mail: Web:	Name: Address: Tel: Fax: E-mail: Web:

(ii) Clause by Clause Commentary against laid down technical specifications:

Specifications of the DWLR, hydrostatic Type (GW) with telemetry system

Name of Goods-Its Features	Required Specifications and standards as per bidding document	
Site Conditions		
Ambient Temperature	From 0 to 60 degree	
Humidity	5-100%	
Altitude	0-2500meter	

DWLR—Water level and Temperature Sensor

Sensor Type	Submersible pressure transducer with Non-Vented Pressure Sensor with Barometric Pressure Correction for Individual Sensor.
Range	(30m, 45m,75m,105m,120m)
Installation Depth (Cable length)	Tentative depth as per the attached list. Concerned Regional Director will decide the depth of installation at the time of drilling of piezometer
Dimension	Outer diameter of sensor unit:<80mm,(for sensor)
Material	Stainless Steel (SS-316)or other better corrosion resistant material
Ingress Protection	IP68 for sensor
Over all Accuracy	0.20% FSO

Resolution	3mm
Reproducibility	0.1% full scale or better
Long Term Stability	0.1% Full scale and should ensure long term stability without any field calibration requirements except barometric compensation.
Temperature Measuring Range	0 to 50°C
Temperature Measuring Accuracy	Better than $\pm 0.3^\circ\text{C}$
Burst Pressure	≥ 2 Time Full scale
Overload Pressure	1.5 Time full scale without effect on calibration
Over-voltage Protection on supply & sensor wires	Should include lightning ,over-voltage and surge protection
Output	SDI-12,RS-485,4-20mA or compatible with data logger.
Installation	The system should be provided with a suspension bracket, Well enclosure / canopy & junction boxes (if required) allowing secure installation within the Piezometers' head work, including appropriate cable mounting accessories to allow the sensor to be adjusted to the required depth.
Direct Read <u>Sensor</u> Cable	<p>The cable shall have following features:</p> <ul style="list-style-type: none"> • Strength members for good longitudinal stability of cable • The cable and contacts should be fixed or quick connect • Cable screen to be connected to the data logger ground terminal to minimize electrical interference. • A cable suspension bracket allowing the DWLR to be adjusted to the required depth, in a stable and reproducible manner. • Corrosion and moisture free as the equipment has to work under water condition. • Cable should have good flexibility. • Should be of Polyurethane Jacket or better. The electrical wires shall have sufficient conductivity to allow for extension of the cable to up to 200 m without degrading accuracy, stability and data communication.

DWLR Data logger

Atmospheric Pressure correction	Atmospheric Pressure corrections to be applied automatically
Resolution of measurement	16-bit ADC with ± 1 LSB accuracy
Measuring interval	Should be programmed to store data from 1 minute one reading to 24 hours one reading.
Settling up Time	< 30 minutes after submersion.

Recording Capacity	Shall store the data for at least 1 year
Memory Type	Non-Volatile flash memory that can store one year of data (with 15 minute logging interval)
Power Supply	Should be equipped with lithium or alkaline battery pack, giving at least 2 years operation (with one transmission and four recordings per day). Battery must be replaceable in the field or in local offices of the implementing Agency or supplier. Replacement of batteries must be readily available in India.
Battery Voltage Monitoring	Monitoring and transmission of Battery Voltage level
Data logger Location	Data logger should be located on top (on ground surface).
Built in clock	Accurate to ± 1 minute per Year
Displayed time resolution	1 second or better
Over-voltage Protection on supply & sensor wires	Should include lightning, over-voltage and surge protection
Protection	IP 68 with Impact Resistant for Water level sensor IP 65 (for data logger) with Impact Resistant
Port for configuration	One serial port for communication with laptop for programming
Ports for telemetry	Port for communication with GSM & GPRS telemetry
Operating System	Windows based software for system configuration / communication
Licenses	All required licenses shall be included
Real time clock	Time synchronization facility shall be provided with IST
Accessories	Serial cable and adaptor if required alongwith all accessories and fixing units etc.

Communication Interface

Computer Interface	The Logger must be capable of connection to a computer via USB 2.0/ USB 3.0 and supply should include the necessary interface cables.
File Format	The format of the data downloaded by communication interface shall be in standard CSV format (as specified in technical Specifications) which is compatible with India WRIS/ WIMS software.

GSM & GPRS Transmitter

Transmission System	GSM /GPRS / edge-based data transmission system
Frequency range	900 MHz: 824-960 MHz/ 1800 MHz: 1710-1880 MHz 4G and better
Performance	Data Reception availability of 95 % or better

Communication Direction	Utilize GPRS network for two-way connection with connection with FTP ,TCP/ IP (INTERNET)connection and SMS server
Transmission trigger	Data collection to be triggered by interrogation from Data Center or by event-based transmission triggered by remote site
Power Saving	Ability to disable interrogation system in order to save power at remote site
Communication Protocol	Data transmission to execute HTTP Post or FTP, SMS to transmit data to the Data Center
Accessories	All associated equipment, including Antenna all cables and mounting hardware

Software for Data logger

Operating System	Windows based software for system configuration, transfer and analysis of data to computer
Version	English language version
License	All required licenses included

General Features

Battery	The battery should be easy to replace, and easily available in the market.
Tools	Complete tool kit for installation and routine maintenance
Manuals	Full documentation and maintenance instructions in English
Training	As per mutual consent at the time of installation of telemetry system
GSM/GPRS transmission format	As specified in the technical Specification table for GSM /GPRS communication format

Specifications of Data Acquisition Software (DAS):

SI	Required Specification and Standards as per Bidding Document	Specification and Standards as offered in by Bidder	Remarks
1	<p>Data collection performance:</p> <p>Bidder should ensure seamless data and responsible for</p> <ul style="list-style-type: none"> Real-time data collection at all DWLR stations & shall ensure seamless data transfer. The data from DWLR stations will be transmitted through GSM/GPRS in the standard CSV format (as specified in Technical Specifications) to FTP server 		

	<p>at the National Data Centre, CHQ, Faridabad</p> <ul style="list-style-type: none"> From RODC, the data will be transmitted to NDC, Faridabad & India WRIS/ WIMS software through internet. This data will be processed and disseminated via India WRIS/ WIMS cloud. <p>The processed data from India WRIS/ WIMS in the form of reports/ bulletins will be transmitted to National Data Centre, CHQ, Faridabad & National Data Centre, Faridabad.</p>		
2	<p>Data maintenance:</p> <p>All activities pertaining to installation, data services, Operation & maintenance at the remote DWLR station will be maintained by the bidder during the warranty and maintenance period and will include a log of activities during every station visit.</p>		
3	<p>Reports & Bulletins Storage system: Storage of all data, reports & bulletins in the proper manner and easy to access. This data will be backed up in such a way that it is not possible to lose data that has already been stored with the use of mirrored or replicated storage.</p>		
4	<p>Helpdesk:</p> <p>Bidder to operate help desk to respond to queries from the purchaser. Help desk will be able to solve any problems related to data collection, processing, and dissemination to the purchaser. Help desk shall be available from 8am to 6 pm, Monday–Sat.</p>		

Specifications for Data Transmission System:

Sl.No:	Required Specification and Standards as per Bidding Document	Specification and Standards as offered in by Bidder	Remarks
--------	--	---	---------

	The transmission system should be tightly integrated with the DWLR System, along with compact remote / field mounted consisting of sensor, data logger, modem and antenna and other accessories complete.		
1	The system should be watertight (IP 68 for sensor & IP 65 for data logger or equivalent) and impact resistant;		
2	The system should allow easy access for monitoring measurements without removing complete system.		
3	System must be power-supplied by standard lithium /alkaline batteries for operation time of at least two years by one set of batteries (one transmission per day,4 measurements per day) and must be placed in a water resistant (IP65 or equivalent) enclosure. The replacement of batteries during five years warranty and two years of O&M would be responsibility of the bidder, at bidder's cost .		
4	The system must have integrated energy management system using free programmable time slots for measurement and transmission to minimize power consumption;		
5	The connectors should be water-tight (IP 68 or equivalent).		
6	An alarm notification must be sent by the system via SMS to user defined phone numbers through suitable means of communication for user defined parameters. This includes battery performance (battery voltage).		
7	Standard USB /RS 232 communication interface should be available for set up and configuration and must be easily accessible.		
8	Data logger shall be provided with Atmospheric Pressure sensor at individual station, & Atmospheric Pressure correction		

	shall applied automatically on the raw water level reading from non-vented water level sensor. The details of correction procedure shall be fully documented in user manual. Provision shall be made to view and store the raw and compensated water level data along with atmospheric pressure and Water Temperature data in data logger memory		
9	All measurement and setup options, data download and programming of data loggers shall also be done by online sessions similar to all functions at site by direct connection to a PC		
10	Data download /retrieval from remote DWLR station to central server PC via GSM & GPRS network shall be provided. The data from remote station should be in standard CSV format (as specified in technical Specifications) which is compatible with India WRIS/ WIMS software		
11	The software should be provided to allow download the data from the DWLR data logger to a Laptop / hand held devices in the field. The downloaded data shall be in standard CSV format (as specified in technical specifications) which is compatible with India WRIS/ WIMS software.		

Specifications of Data Server		<u>Make:</u> <u>Model No:</u> <u>Manufacturer Name, address, email, phone, website, fax</u>	
S.No:	Required Specification and Standards as per Bidding Document	Specification and Standards as offered in by Bidder	Remarks
1.	<ul style="list-style-type: none"> • Server having two nos. of x86 64-bit processor (Intel Xeon E5-2620 v4 or better), • 64 GB DDRIII expandable to 256 GB or more, • Integrated Graphics Controller, • SAS RAID Controller supporting RAID0,1, 		

	<ul style="list-style-type: none"> • 2*600 GB SAS Hot Swap HDD (10 K or higher RPM), • Dual 1 Gbps Network port, • DVD WRITER, • 23" LED Monitor with a resolution 1920 X1080 or better, • OEM Key board and OEM Mouse, • Server Chassis having Redundant Hot Swappable Power Supply with 8 Hot Swap drive bays, • Certification for Linux and Windows, • All required device drivers for System Configuration and Server Management Support including data storage facility of 8 TB for 5 years and all accessories and • Perpetual license for window server (2012 or later), perpetual license for MS Office, firewall system with Good antivirus etc. 		
--	--	--	--

Specifications of Computer node (Work station)		<u>Make:</u> <u>Model No:</u> <u>Manufacturer Name, address,e mail, phone, website, fax</u>	
Required Specification and Standards as per Bidding Document		Specification and Standards as offered in by Bidder	Remarks
1	Windows10 Home / Professional or above		
2	Intel H 270 and above or equivalent		
3	Intel® Core™i7-6700T with Intel ®HD Graphics 530 (2.8 GHz, up to 3.6 GHz, 8 MB cache, 4cores) and above or equivalent		
4	8GB DDR 3L and above or equivalent (RAM)		
5	1TB 7200 rpm SATA or better		
6	58.42cm (23) diagonal WLED-backlit (1920x1080).Touch-enabled (optional)		
7	DVD-Writer		
8	Integrated 10/ 100/ 1000 Giga bit Ethernet LAN		

9	802.11b/g/n(1x1) and Blue tooth @4.0 combo(Optional)		
10.	4 USB 2.0; 2 USB 3.0; 1 Head phone / microphone combo		
11.	USB wired / wireless optical mouse		
12	USB wired / wireless standard key board		
13	Preinstalled MS Office Lifetime with Good antivirus is preferred.		

Specifications of Color printer	<u>Make:</u> <u>Model No:</u> <u>Manufacturer Name, address , email,</u> <u>phone, website, fax</u>	
Required Specification and Standards as per Bidding Document	Specification and Standards as offered in by Bidder	Remarks
A 3 Size color printer		
Functions: Print, Copy, Scan		
Printing Upto 20 page/minute		
Black & color printing: As fast as 9.5 sec per page		
Recommended monthly page volume: 250 to 2000		
Processor speed: 600 MHz		
Connectivity: e-Print capability		
Paper handling input, standard:100 sheet input tray		
Paper handling output, standard:100-sheet face-downbin		

Specifications of Display Unit LED)	<u>Make:</u> <u>Model No:</u> <u>Manufacturer Name, address, email,</u> <u>phone, website, fax</u>	
Required Specification and Standards as per Bidding Document	Specification and Standards as offered in by Bidder	Remarks
Screen Type: 42"Screen LED		
Display resolution:1920x1080		
Colors: 256 K colors		

Interfaces: 1x Ethernet (RJ45) (max. 12Mbit/s), HDMI port, USB port 1x USB Multimedia card/SD card slot combined		
Industrial Ethernet: 1x Ethernet (RJ 45)		
Protocols: Protocol (Ethernet) TCP/ IP		
Image formats Supported: JPEG, JPS, MPO		
Sound technology: Dolby digital		

4. DRAWINGS

Deleted

5. INSPECTIONS AND TESTS

The following inspections and tests shall be performed:

General:

1. After manufacture, the supplier shall get each equipment/item of Goods inspected in manufacturer's works as per approved data sheets and QAP and forward to the Purchaser along with his letter seeking to inspect an equipment/item of Goods conform to contract specifications.
2. Upon receipt of the test certificate and calibration certificates, the purchaser or its representative shall arrange for inspection and/or test of any or part or all the equipment / Goods prior to issuance of dispatch clearance . In cases where the supplies are received from abroad, the purchaser may waive the pre-dispatch inspection.
3. However, the inspection and dispatch clearance by the Purchaser or the waiver thereof shall not prejudice the right of the Purchaser or its consignee to test the equipment/goods on receipt at destination. Upon receipt of the goods at final destination, the Purchaser shall have the right to inspect and/or test the equipment/Goods to confirm their conformity to contract specifications.
4. If the equipment fails to meet the contract specifications during inspection, whether pre dispatch or upon receipt of at final destination, the supplier shall take immediate steps to remedy the deficiency or replace the defective equipment to ensure that all supplies meet with the specifications specified in the contract

Inspection and tests prior to shipment of Goods and at final acceptance are as follows:

1. The inspection of the Goods shall be carried out to check whether the Goods are in conformity with the approved technical specifications attached to the contract and shall be in line with the inspection / test procedures laid down in the Technical Specifications and the General Conditions of contract. Following broad test procedure will generally be followed for inspection and testing of instruments. The supplier may dispatch the goods to the ultimate consignee after internal inspection testing along with the supplier's inspection report and manufacturer's warranty certificate based on the inspection waiver from purchaser. The purchaser will test the equipment after completion of the installation and commissioning at the site of the installation.
 - a. Site Preparation and Installation: The Purchaser will designate the installation sites before the scheduled installation date to allow the Supplier to perform a site inspection before the installation of the DWLRs and associated telemetry system. In case there is a delay in handing over the site by the purchaser, appropriate extension of time shall be granted without imposition of liquidated damages in accordance with the provisions of contract.
 - b. For site preparation, the supplier should furnish all details (installation drawings) to the purchaser sufficiently in advance so as to get the works completed before receipt of the equipment.
2. Complete hardware and software as specified in 'List of Goods and Delivery Schedule' Under the Schedule of Requirement

- should be supplied, installed and commissioned properly by the supplier prior to commencement of performance tests.
3. The acceptance test will be conducted by the purchaser/their consultant or any other person nominated by the purchaser, at its option. The acceptance will involve **trouble-free operation for seven consecutive days**. There shall not be any additional charges for carrying out acceptance tests. No malfunction, partial or complete failure of any part of hardware attached to printers, drivers etc. or bugs in the software should occur. All the software should be complete and no missing modules /sections will be allowed. The supplier shall maintain necessary log in respect of the results of the tests to establish to the entire satisfaction of the purchaser, the successful completion of the test specified. An average uptake efficiency of 90% for the duration of test period shall be considered as satisfactory.
 4. In the event of the hardware and software failing to pass the acceptance test, a period not exceeding **two weeks** will be given to rectify the defects and clear the acceptance test, failing which the purchaser reserves the rights to get the equipment replaced by the supplier at no extra cost to the purchaser.
 5. DWLRs procured would be subject to the Acceptance Protocol given below

ACCEPTANCE PROTOCOL

1. General

- a. The delivery of goods/equipment and software should be in accordance with the contract agreement and the process of delivery will adhere to the following 'Acceptance Protocol'. The Acceptance Protocol shall serve as a formal guidance during delivery of the DWLRs. Its primary goals are twofold.
 - i. Ascertain the delivery and completeness of all ordered products and related documents.
 - ii. Check the functioning of the equipment and software in a formal way against the specifications by application of Acceptance Tests. The tests also verify the accuracy and stability of the equipment.
- b. The Acceptance Protocol shall be executed in close co-operation between the Supplier and the Client.
- c. Products shall be accepted only if they meet the requirements and are functioning in compliance with the technical specifications, and the related documents are complete and correct. Defective products and any other discrepancies shall have to be replaced/ resolved, within a pre-defined time frame as specified in bid document.

2. Documents

- a. The following documents shall accompany the delivery of the instruments and software:
 - i. Administrative and Quality Assurance (QA) documents
 - ii. Test and calibration documents
 - iii. Manuals and Guidelines

All documents shall have identification and references to subject or instrument, date, time, location and officer-in-charge.
- b. The Acceptance Report lays down the findings and observations during the execution of the Acceptance Protocol and is a formal document to record the acceptance or rejection of any item as covered in the Bid document. Any flaws or findings are to be reported. The forms and check lists filled out during the execution of the Acceptance Protocol are to be enclosed with the Acceptance Report. The Supplier receives a signed copy of the Acceptance Report, which the Supplier can use as proof that the items listed in the report were accepted.
- c. The content of the various documents shall be as follows:

2.1 Administrative and QA documents: These QA documents shall include:

- i) Production documents associated with the instruments.
- ii) Type codes, serial numbers and other identification data on, possibly externally procured, sensors and major

assemblies, to clearly demarcate the sensors /major assemblies associated with each DWLR.

- iii) Shipping documents indicating instrument/product type, serial number, measuring range, cable length and other similar data.

2.2 *Test and calibration documents:*

- i) A comprehensive Method Statement on the applied calibration and in-factory test procedures shall accompany the bid. The Method Statement should define the test and calibration methods applied on the instruments and the components thereof. The Method Statement shall also include, for each calibrated product, an audit trail to national standards on all instruments and facilities used for testing and calibration. The Audit Trail Report shall associate the calibration of the reference instruments and test equipment to the national calibration standards.
- ii) If the Supplier or Manufacturer is not in a position to deliver an Audit Trail Report to the national standards, the Manufacturer shall explain what the quality standards are and how they are maintained and monitored.
- iii) Conditions during calibration, such as room and /or instrument temperature, equipment and facilities used, shall be included in the calibration and test documents.
- iv) The test and calibration documents shall contain the data generated during calibration and testing, including:
 - Calibration data supplied by the Manufacturer of pressure sensor
 - Calibration and test data of the data-logger electronics
 - Calibration data on overall DWLR calibration, i.e. comprising both pressure sensor and electronics. A table listing applied reference pressures versus instrument readings is to be delivered for each sensor and instrument. Further more, that table shall also show the test conditions during calibration
 - Data on hysteresis test, temperature tests, zero stability test, scale stability test
 - Humidity test, in particular for vented gauge pressure sensors
 - Temperature cycling of sensor and electronics
 - Spray test on enclosure(s),connectors and cables

2.3 *Manuals and Guidelines*

- i) The manuals shall meet the requirements on style and clarity, completeness, preciseness, detail and accessibility. This includes:
 - System manual,
 - Operation, Maintenance and Service manuals,
 - Observation guideline, and
 - Training handouts.

3. Acceptance Tests

1. *General*

- i) Qualified engineers under responsibility of a test manager shall execute the Acceptance Tests. The progress of the Acceptance Tests would be monitored and supervised by the Client and/or his authorised representative. The Client may have any tests redone or additional tests executed as deem required based on the results of previous tests conducted. The Client's and/or his authorised representative shall have the right of access to any instrument and may request any data or information at any time. The Supplier has the obligation to deliver requested information without delay; i.e. collected test data and documents must be available at the test site.
- ii) It is important that all activities (what, when, where, who, which instrument, etc.) are annotated and uniquely linked to the

individual instruments.

iii) The Acceptance Tests mainly comprise three levels viz.:

- Functional Tests: The Functional Tests shall verify the proper functioning of the instruments and the associated software. Primary goal is to verify that the instrument performs its functions according to the bid specifications.
- Accuracy Tests: The Accuracy Tests shall verify that each individual instrument is functional and operates according to the bid specifications. A number of relatively simple accuracy tests are routinely exercised on the instruments.
- Overall Test: The main purpose of the Overall Test is to verify the common features that are identical to all the instruments in a series. Typical components of the Overall Test are: - in-built software functions, materials of the instrument, cables, connectors, etc. Further tests include battery and memory autonomy, details of sensor specifications like temperature effects, hysteresis, long term stability etc.
- The above tests can be executed at any one of the following locations: -Premises of the Manufacturer /Supplier; Premises of the Client; Independent organisation; at Site of installation

iv) The charges for testing shall be borne by the Manufacturer/Supplier. The Client and/or his authorised representative may at his cost opt to be present during the performances of the tests.

v) If the tests are executed at the Client's premises, the charge for testing shall be borne by the Client and the Supplier shall be responsible for conducting the tests. The bidder in his bid shall indicate the name of independent organisation and the charges for testing. The Client reserves the right to accept the independent organisation and its charges or get the tests done by any other agencies. However, the Supplier would be permitted to be present at these tests.

(Explanatory Note: Test report from manufacturer would be acceptable. In case purchaser desires to test the system from independent agency (ies), testing charges would be borne by purchaser.)

vi) The details of these tests are as follows

1.1. Functional Tests: The Functional Tests include: visual inspection, and user tests.

1.1.1 Visual Inspection: Visual inspection includes the following activities.

- i) All items are visually checked for damage, e.g. on cables, sensor and housing.
- ii) Availability of non-removable identification codes and specifications are verified, e.g. serial number, type identification, manufacturer and measuring range.
- iii) Cables have to be marked: each cable is to have an identification code and name.
- iv) Cable connectors shall have their ends marked suitably to indicate the device to which it is to be connected, e.g. PC, HHT, Power Supply etc. Suitable precaution shall be taken so that the connectors are not connected to wrong terminals, i.e. it shall be impossible to connect a power cable to a communication bulk head socket.

1.1.2 User tests

- i) All instruments have to be identical except for measuring range, cable length, identification code and similar aspects. Consequently, there is no need to check the functionality of all systems. It is assumed that the functional compliance with the specifications is tested under the Overall Tests. The objective of the user test is to detect any malfunction and/ or defect. From practical point of view, the user tests can be coupled with other test, e.g. the stability tests.
- ii) Basic functions to be tested are:
 - Pre-deployment preparation, e.g. setting of clock, erasing of memory, setting data logging parameters, entry of identification data
 - Facilities for execution of on-site functional checks
 - Data retrieval and data transfer to PC

- Battery status and voltage
- Simple output test by observing pressure reading while the sensor is immersed in a bucket filled with water

1.2 Accuracy Tests: The Accuracy tests include:

- Accuracy tests on clock, and
- Accuracy tests on pressure measurement

1.2.1 Accuracy tests on clock

- The clock of the data logger shall be carefully checked against national time, e.g. taking the radio broadcast time beeps as a reference. The data logger clock is set precisely and checked at the start of the individual tests and upon instrument and/or data retrieval. In between, the clock should not be readjusted.
- The clock test shall cover at least 3 days to get sufficient time resolution. The reference clock, e.g. a watch, must be carefully tuned against national time prior to and during the tests. The clock drift, converted to seconds per month (31 days) shall comply with the defined specifications. This test method makes use of the specified time resolution of 1s.

1.2.2 Accuracy tests on pressure measurement

- The accuracy test on the pressure sensor is an overall accuracy test covering both the pressure and electronics systems. The pressure tests are to be executed against accurately known reference pressure(s). Pressure can be generated from compressed air (gas) or by submerging the sensor to known depths in water.
- Reference pressure may be created via a precision pressure reduction valve from a source of compressed air. A high precision sensor like a Digi Quartz pressure sensor or a Dead Weight Tester can be implemented to quantify the applied pressure. Pressure should be measured in kPa (or mbar).
- When applying the immersion method it is much more difficult to check the instruments because water density affects the reading. Moreover, it is not simple to establish the exact depth of sensor immersion. And especially in narrow wells, while immersing a pressure sensor on its cable into a well, the water level will rise due to the additional volume of the immersed pressure sensor and cable. The water level will gradually fall again, when the well level adjusts again to equilibrium with the ground water level. In order to achieve a high accuracy these effects have to be assessed.
- The pressure sensor tests include:
 - Zero stability test
 - Scale test
 - Scale stability test
- The pressure sensor tests shall focus on temperature effects on zero, scale and cable length, and in addition to that establish quantitative data on drift of zero, scale and creep of cable length.

1.2.2.1 Zero stability test

- During the zero-test the instruments are in logging mode, say at an interval of 30 minutes, and shall be kept in a separate room where they will not be touched for at least 3 days. The instruments must be dry, i.e. not in a bucket of water, to exclude any water effect on the sensor, and hence, the instrument reading is expected to be 0.0.
- Under this test, each instrument will record its short term zero drift and inherently the effectiveness of the air-pressure compensation method. During the zero-test, the instruments shall be in the same and constant position, vertical or horizontal. The room temperature shall vary over 5 °C or more, e.g. due to daily temperature fluctuation, this to assess temperature effects on the instrument reading. This requirement may affect the choice of venue for the zero-tests. To avoid any adverse temperature strain, no direct

sunlight shall fall on the instruments. At the end of the test, the collected data are off loaded from the data logger memory and analyzed for zero stability. As the instruments are kept in air and are not touched, the reading shall be stable and not change over time that is not beyond permissible limits.

iii) Room temperature is to be logged against time, preferably by digital method. In case the DWLR has a built-in temperature sensor, that sensor may be used for temperature logging. The pressure sensors shall not be tested in an air-conditioned room for several reasons. First, temperature fluctuations may be so rapid that the sensor temperature compensation scheme may not be able to cope with it. Moreover, rapid air-pressure fluctuations may not be handled properly by the air-vent system and/or the pressure measurement method. This is to be understood from the perspective that the instruments are designed to operate in wells where changes occur but not rapidly. One or more fans may be operated continuously to minimize temperature gradient across the test room.

iv) To test the creep and elongation of the electrical cum suspension cable some vertical open space is required, e.g. a stair well can be used for this purpose. However, it is important that the cable is protected against touch to avoid interference with the

measurements. The cable is loaded with some weight to emulate the weight of cable and sensor. The length of cable under tests shall be as long as possible, i.e. 10 m or more, to get the best accuracy of the tests. The lowest point is suspended to about 0.15 m above the floor. The gap between lowest point and floor is monitored against time. Initially readings are taken every 30 minutes for 12 hours, subsequently the reading interval may be increased to 6 hours. The cable test shall be executed during 7 days. Resolution of measurement should be 1 mm or better. The result is to be presented in mm length change per meter suspended cable length. Only one cable is to be tested.

1.2.2.2 Scale test: A precisely known pressure is applied on the instrument and the instrument reading is taken. The instrument reading is converted into level or pressure whatever is applicable. The calculated value is compared with the applied value; the difference is regarded as the FS error. In case the specifications of the applied pressure sensor may give reason to doubt the instrument's linearity, then a mid-scale test is to be executed as well.

1.2.2.3 Scale stability test: Scale stability is tested by subjecting the instrument to the full-scale pressure for at least 24 hours. During the test, the applied pressure/ level is to be accurately monitored by taking reference readings either by a reference logger of high accuracy or by manual readings. The accuracy and resolution of the reference measurement must be 1 mm water column or 0.01 kPa (0.1 mbar).

1.3 Overall Test: Part of the Overall Test is also covered under the Functional Tests and Accuracy Tests. The Overall Test comprises tests on:

- autonomy
- fitness for environment
- functionality
- calibration
- stability
- reproducibility, and
- main power failure

Details of the various tests are as follows.

1.3.1 Autonomy: Two autonomy tests shall be conducted:

- Battery capacity versus the power consumption per measurement, and
- Memory capacity

i) **Battery autonomy test:** To execute the test, the instrument is set to a fast data collection interval and the

capacity, i.e. the number of samples, is established by a continuous process of data collection until the batteries are depleted. The test shall be executed on new batteries. In this context, the batteries are deemed depleted when the instrument stops functioning because the battery voltage watch-dog function detects a too low battery voltage or the normal operation of the instrument stops.

- ii) Memory capacity verification: The memory is filled at the highest data-recording rate and the volume of collected data is verified against the bid specification. This test could be combined with the battery autonomy test and the samples are taken at a high rate to minimize the test duration.

1.3.2 *Fitness for environment*

- i) Connectors, cable glands, cables and housing must be suitable for the environment of operation, be it submersed, in a well or above the ground. Water ingress can be assessed by visual inspection and / or by insulation measurement. Visual inspection may only reveal ingress of a significant amount of water. The insulation measurement is more sensitive, especially for cables, connectors and encapsulated electronics, but requires specialized equipment.
- ii) The above-surface components have to be compatible with IP5 standard and shall be tested accordingly by exposing them to a heavy shower for 3 minutes. Subsequently the ingress of water is assessed by opening of the instrument and connectors.
- iii) The submersible components must comply with IP 68 standards. To verify this, the instrument shall be suspended in a well for at least one week, to a maximum depth, without affecting the calibration of the pressure sensor and not exceeding 2 times the rated measuring range. Although most pressure sensors can withstand considerably more than 2 times the rated measuring range, there is no need to exceed this. Prior to this test, the zero and scale of the sensor have to be established and verified again upon recovery.

1.3.3 *Functionality*

- i) Functionality has to be verified for all requirements for operation of the DWLR with reference to the bid specifications and the instrument specifications as given by the Manufacturer. Missing functionality shall be reported.
- ii) All (software) functions as stated in the instrument manual(s) and the instrument specifications are tested for correct functioning. Any detected flaws are reported which shall be repaired / rectified by the Manufacturer / Supplier within seven days.

1.3.4 *Calibration*

- i) The instrument calibration is checked for compliance with the bid specifications. In particular accuracy, stability, linearity, hysteresis and reproducibility are verified.
- ii) The scale or sensitivity of the complete instrument, including sensor and electronics, is to be checked for at least 11 pressures, equally distributed over the full measuring range. Furthermore, the calibration data as delivered with the instrument are verified for accuracy and consistency with data obtained from the calibration tests. The calibration may be executed by application of accurately known air-pressure or by immersion in a well. The temperature effects on the calibration should also be verified at low, mid and maximum range temperatures.
- iii) **Note:** Prior to execution of immersion tests, the effective position of the sensor membrane relative to the sensor housing is to be assessed and measured, e.g. by execution of a bucket experiment. In this experiment, the sensor is partly immersed in a water filled bucket to a depth where the related reading has changed by several centimeters, relative to the 'in-air' reading. During the test, the position of the water surface on the sensor's body shall be observed and marked accordingly. The 'effective-sensor-zero' lies below the water surface during the test. The position of the effective-sensor-zero is below the above mentioned water-surface mark by the equivalent of the sensor reading expressed in centimeters. The effective-sensor-zero may be close to the sensor membrane but not necessarily coincides with it.

1.3.5 **Stability:** Stability related to the DWLR is defined as a variation over time of the instrument specifications, whereas the circumstances and pressure do not vary. Parameters to be checked are:

- zero: offset stability
- scale: fullscale stability
- cable: length (extension/contraction) and creepstability

The methods to assess these stability factors are explained under the section on Accuracy Tests.

1.3.6 **Reproducibility:** The sensor reading in air is annotated, subsequently the sensor is immersed to the rated measuring depth, and a stable reading is collected. Then the sensor is recovered to the surface and again a stable reading is taken. This process is repeated 5 times and results are duly annotated. It is important that during the complete test the instrument is kept in the same, vertical position.

1.3.7 *Main power failure:*

- i) Some instruments operate on replaceable batteries or even external power and have a built-in back-up facility, usually based on a Lithium battery. It is quite possible that on some instruments the external power supply or the replaceable batteries fail because of total depletion, disconnection, defect on the cable or connector etc. In such an event, the instrument must retain its clock, its program setting and most importantly all the collected data.
- ii) The Functional Tests are executed in conjunction with the stability test. Upon finalizing these tests and after successful retrieval of all test data the power is disconnected by removing the main power batteries and/or disconnecting the power cable. The instrument is to be left in that state for at least 24 hours. Then the power shall be connected again and clock, program settings and recorded data are checked for availability and correctness.
- iii) Instruments with entirely built-in factory replaceable batteries cannot be tested in this way. In such case, the Manufacturer shall provide a technical description of the method applied to avoid loss of clock, program and collected data.

4. Test Execution: Two test programmes are to be executed:

- All Units Test Programme
- Single Unit Test Programme

Prior to execution of the tests, a detailed test script has to be drafted and agreed upon. The test script shall define:

- Test sequence.
- The test conditions and requirements for each test.
- Place of the test.
- person(s) responsible for conducting the tests.
- Reporting requirements.
- Handling failures and problems.

4.1 All Units Test Programme: The All Units Test Programme aims to identify the malfunctioning instruments and those not compliant with the bid specifications. The Functional Tests, the Clock Accuracy Test and the Zero Stability Test must be executed on each instrument. The design of the tests shall be selective and practical and enable execution with simple means, preferably at the Client's premises.

4.2 Single Unit Test Programme

- i) A full system shall be tested, that is: pressure sensor, electronics, cable, power supply, DRS, software and manuals. The Single Unit Test Programme is a combination of the Functional Tests, the Accuracy Tests and the Overall Test. The Client shall randomly select an instrument for testing from the instruments delivered.

The Single Unit Test Programme can only be started after verification that all documents related to the order/delivery, including manuals, calibration data, QA data etc., are delivered to the Client. Any other unit, for which doubts arise on its compliance with the bid specifications, shall also be tested on the client's request.

- ii) Failing to pass the Single Unit Test Programme results in rejection of the entire delivery until the defective units have been repaired to meet the technical specifications and such to the satisfaction of the Client.
5. Evaluation of test results: The test results have to be evaluated and results and conclusion shall be reported. Instruments that do not meet the bid specifications, shall be replaced by properly functioning and satisfactorily tested instruments.
6. Post acceptance performance monitoring
 - i) After installation and field deployment the instrument performance shall be continuously monitored by taking manual observations, initially at a relatively high rate, e.g. every 3 hours, gradually migrating towards the normal monitoring interval. The level comparisons are required for reference and validation purposes. Manual observations and automatic readings shall be taken at short intervals after each other, in practice the time difference shall be kept to less than 15 minutes. The primary criterion though, is that the manual reading shall be taken before the water level changes more than 1 mm.
 - ii) Other checks are on functioning of the internal clock, data recording and retrieval, battery discharge, siltation of the sensor, moisture ingress and any development of corrosion.
 - iii) The tape used for taking the reference readings shall be of high accuracy, considerably better than the accuracy of the DWLR, only then the performance of the high accuracy instruments can be monitored. However, an accuracy of 1 mm over the full measuring range is enough. Only best quality tapes, e.g. the electric types, come close to this requirement. The tapes shall be checked for accuracy against a precise reference, e.g. over 10 or 20 m on a single stretch. Verification by a standard ruler will not reveal to overall accuracy of a tape. The 'tape verification reference' could be prepared using high accuracy geodetic equipment. Along, straight corridor, or a quiet stretch of road, could accommodate the length reference marks, the accuracy should be 1 mm relative to the reference point (0.000m).
7. Instrument History File: For each instrument, an individual History File shall be opened and maintained (The Instrument history file shall be suppliers' scope.). In the History File the full instrument history and all documents generated shall be stored. This also includes any changes, adaptations, repairs etc. made to the instruments. The products and results of the execution of the Acceptance Protocol shall be included in the Instrument History File. Some document types and entries are listed below:

7.1 **Instrument identification:** The instrument identification uniquely defines the instrument particulars.

- Make, vendor, service provider, date of manufacturing, date of delivery
- Instrument make, model and serial number
- Instrument configuration
- Measuring range
- Cable type, length
- Manual version
- Instrument status: e.g. working, under calibration, under repair

7.2 **Functional, Accuracy and Over-all tests:** For each of the three test categories, a separate and unambiguous record shall be maintained. The test conditions and results shall be duly recorded. Obviously any failures or irregularities shall be annotated accurately and comprehensively, as well as the actions taken and their results. At least the following data shall be recorded:

- Administrative data: what, when, where, who, which instrument and configuration
- List of tests
- Specifications for each test
- Results of each test
- Failures, actions, conclusions

8.0 *Acceptance Certificates:*

- On successful completion of acceptability test, receipt of deliverables etc., and after the purchaser is satisfied with the working of the DWLR system, the acceptance certificate signed by the supplier and the representative of the purchaser will be issued. The date on which such certificate is signed shall be deemed to be the date of successful commissioning of the systems

TECHNICAL SPECIFICATIONS WITH QUALITY PROBE

1.0 SCOPE OF WORK

- (i) Complete supply, installation, testing, commissioning of remote stations Digital Water Level Recorders (DWLR) and telemetry system in the identified piezometers including associated civil works, sensors, data logger, software, hardware and ancillary's equipment, etc.
- (ii) Clean Well to be ensured by the contractor before lowering the instruments with its accessories.
- (iii) The scope of work also includes supply of data during Five (5) years comprehensive warranty period and two (2) years AMC period to commence immediately after the expiry of warranty period.
- (iv) Technical design, supply, installation, testing, commissioning of Digital Water Level Recorder (DWLR) with Water Temperature for the real time ground water level & Electrical Conductivity (EC) data collection network and establish data communications using **GSM & GPRS telemetry** between the remote stations and existing Data Centre at Region as specified in BOQ, later to National data center, CGWB, Faridabad and through the India WRIS/ WIMS at New Delhi. This includes, but is not limited to acquiring service, and maintaining all aspects of the service during the Comprehensive warranty period.
- (v) Establish communication between remote DWLR stations with existing GSM & GPRS receiving system along with all required arrangement at Regional Data Center, Region as specified in BOQ to collect GSM & GPRS data from DWLR station network. Bidder shall make necessary arrangement for configuration of FTP Server with adequate protection that will support the seamless transfer of DWLR data stream. And required all acquiring hardware and software, installation, configuration. The data is to be submitted in the requisite format and hence no data processing software has to be provided by the bidder at National data center.
- (vi) Perform on-site assembly, start-up of the supplied goods.
- (vii) Complete commissioning integration, testing & organization of the whole system.
- (viii) Provide operation & maintenance services during Five (5) years comprehensive warranty period and two (2) years AMC period to commence immediately after the expiry of warranty period, which shall include all components at the remote DWLR stations as well as all newly acquired equipment's in the existing data center. The **AMC** must be comprehensive without any exclusion except from force majeure will be permitted.
- (ix) Provide installation and maintenance reports as required by the Purchaser and any delay is not acceptable in time schedule provided by supplier.
- (x) Supply detailed operation and maintenance manual for each component in the system and compile Knowledge and working supply type Manual for training purpose (including multimedia training kits).
- (xi) Provide classroom and field training to the sufficient number of **CGWB** personnel on the DWLR data acquisition system. This includes operation and maintenance procedures. Training will also occur at selected field locations as selected by the Purchaser.
- (xii) A guarantee by the manufacturer that all equipment being provided will be supported for a minimum of ten years after the commissioning of the Digital Water Level Recorder (DWLR) Systems. .
- (xiii) Calibration and validation of the installed system shall continue during the entire **Warranty** period on half yearly basis.
- (xiv) The remote stations shall store the data for at least one year.
- (xv) Supply a detailed operation and maintenance manual for each appropriate unit of supplied goods.

- (xvi) Security of installed equipment's against theft and vandalism will be the responsibility of the Bidder till final site acceptance.
- (xvii) Although all accessories and fixtures required for installation of the equipment & their specifications have been specified in technical specifications however, bidder shall ensure the satisfactory performance & functioning of DWLR system complete, for this if any accessory or items are required that shall be provided by bidder, the cost towards that is deemed to be included in the cost tendered by the bidder, no extra cost shall be paid to the bidder on this account.
- (xviii) Ensure that all software licenses and maintenance agreements are in the name of Purchaser and should seek full support and updates for such software for the duration of the warranty period and Annual Maintenance Services Period. All the software licenses should be valid for the design life of the system that is 10 years from date of commissioning.

2.0 Technical Specifications of Equipment

The Goods and Related Services shall comply with following Technical Specifications and Standards:

(A) Specifications of the DWLR, hydrostatic Type (GW) with Telemetry System

Specifications for Water Level and Temperature sensor

Feature	Value
Site Conditions	
Ambient Temperature	From 0 to 60 °C
Humidity	5-100 %
Altitude	0-2500 meter
DWLR Water Level Sensor with Temperature Sensor	
Sensor Type	Submersible pressure transducer with Non-Vented Pressure Sensor with Barometric Pressure Correction for Individual Sensor Sensors should measure Ground Water level, Ground Water temperature and Electrical Conductivity
Range	(30m, 60m, 120m, 200m, 300m)
Installation Depth (Cable length)	Tentative depth as per the attached list. Concerned Regional Director will decide the depth of installation at the time of drilling of piezometer
Dimension	Outer diameter of sensor unit: <80mm, (for sensor)
Material	stainless Steel (SS-316) or other better corrosion resistant material
Ingress Protection	IP68 for sensor
Accuracy	0.2% FSO
Resolution	3 mm

Reproducibility	0.1% full scale or better
Long Term Stability	0.1% Full scale and should ensure long term stability without any field calibration requirements except barometric compensation
Temperature Measuring Range	0 to 50°C
Temperature Measuring Accuracy	Better than $\pm 0.3^\circ\text{C}$
Burst Pressure	≥ 2 Time Full scale
Overload Pressure	1.5 Time full scale without effect on calibration
Over-voltage Protection on supply & sensor wires	Should include lightning, over-voltage and surge protection
Electrical Conductivity Sensor:	
Sensor Type	Balanced –electrode cell
Range	5 $\mu\text{S/cm}$ to 100,000 $\mu\text{S/cm}$ (0.005mS/cm to 100 mS/cm)
Accuracy	$\pm 0.5\%$ of measurement value or (min. $\pm 10 \mu\text{S/cm}$)
Resolution	1 $\mu\text{S/cm}$
Pressure Rating	As per installation depth
Note- The output of the Electrical Conductivity Sensor will be integrated with datalogger at Selected DWLR site, Bidder may offer combine Water Level, Temperature and Electrical Conductivity sensor or separate combination of sensors	
General	
Output	SDI-12, RS-485, 4-20 mA or compatible with data logger.
Installation	The system should be provided with a suspension bracket , Well enclosure /canopy & junction boxes (if required) allowing secure installation within the Piezometers' headwork, including appropriate cable mounting accessories to allow the sensor to be adjusted to the required depth.
Direct Read Sensor Cable	The cable shall have following features: <ul style="list-style-type: none"> • Strength members for good longitudinal stability of cable • The cable and contacts should be fixed or quick connect • Cable screen to be connected to the data logger ground terminal to minimize electrical interference. • A cable suspension bracket allowing the DWLR to be adjusted to the required depth, in a stable and reproducible manner. • Corrosion and moisture free as the equipment has to work under water condition. • Cable should have good flexibility. • Should be of Polyurethane Jacket or better • The electrical wires shall have sufficient conductivity to allow for extension of the cable to up to 200m without degrading accuracy,

	<p>stability and data communication.</p> <ul style="list-style-type: none"> 25mm dia PVC pipe with BIS mark should be provided for housing the cables in the bore-hole.
Data logger	
Atmospheric Pressure correction	Atmospheric Pressure corrections to be made automatically
Data Logger Input	<p>Level sensor*, Temperature sensor</p> <p>* only compensated water levels need to be transmitted to data base, however barometric pressure/uncompensated water levels may be stored in data logger and shall be transferred to the data base periodically.</p>
Resolution of Measurement	16-bit ADC with +/- 1 LSB accuracy(1 mm or better)
Measuring interval and measuring modes	Should be programmed to store data from 1 minute one reading to 24 hours one reading.
Settling up Time	< 30minutes
Recording Capacity	Shall store data of at least 1 year
Memory Type	Non-Volatile flash memory that can store one year of data (with 15minute logging interval)& expandable up to minimum 1 GB using USB/SD Card.
Power Supply	Should be equipped with lithium or alkaline battery pack, giving at least 2 years operation (with one transmission and four recordings per day). Battery must be replaceable in the field or in local offices of the implementing Agency or supplier. Replacement of batteries must be readily available in India.
Battery Voltage Monitoring	Monitoring and transmission of Battery Voltage level
Built in clock	Accurate to ± 1 minute per year
Displayed Time Resolution	1 second or better
Protection	<p>IP68 with Impact Resistant for Water level sensor</p> <p>IP65 (for data logger) with Impact Resistant</p>
Port for configuration	One serial port / USB for communication with laptop for programming
Ports for telemetry	Port for communication with GSM & GPRS telemetry
Operating System	Windows based software for system configuration / communication
Licenses	All required licenses shall be included
Real time clock	Time synchronization facility shall be provided with IST
Accessories	Serial cable and adaptor if required along with all accessories and fixing units etc.
Communication Interface	
Computer Interface	The Logger must be capable of connection to a computer via USB 2.0/USB

	3.0 and supply should include the necessary interface cables.
File Format	The format of the data downloaded by communication interface shall be in standard CSV format (as specified in technical Specifications) which is compatible with India WRIS/ WIMS software.
GSM &GPRS Transmitter	
Transmission System	GSM /GPRS/edge-based data transmission system
Frequency range	900 MHz: 824-960 MHz/1800MHz:1710-1880 MHz 4G and better
Performance	Data Reception availability of 95% or better
Communication Direction	Utilize GPRS network for two-way connection with connection with FTP, TCP/IP (INTERNET) connection and SMS server
Transmission trigger	Data collection to be triggered by interrogation from Data Center, or by event-based transmission triggered by remote site
Power Saving	Ability to disable interrogation system in order to save power at remote site
Communication Protocol	Data transmission to execute HTTP Post or FTP, SMS to transmit data to the Data Center
Accessories	All associated equipment, including Antenna all cables and mounting hardware
Software for Data logger	
Operating System	Windows based software for system configuration, transfer and analysis of data to computer
Version	English language version
License	All required licenses included
General Features	
Battery	The battery should be easy to replace, and easily available in the market.
Tools	Complete tool kit for installation and routine maintenance
Manuals	Full documentation and maintenance instructions in English
---Training	As per mutual consent at the time of installation of telemetry system

Specifications for Data Services

Bidder is to acquire, manage, and operate data collection, storage and dissemination to support the following activities during 5 years warranty period and 2 years comprehensive AMC period for DWLRs with telemetry system.

Note: A server and storage system for additional backup shall be provided at National Data Center

S No.	Parameter	Functionality requirement
-------	-----------	---------------------------

S No.	Parameter	Functionality requirement
1	Data collection performance	<p>Bidder should be seamless data and responsible for</p> <ul style="list-style-type: none"> • Real-time data collection at all DWLR stations & shall ensure seamless data transfer. • The data from DWLR stations will be transmitted through GSM/GPRS in the standard CSV format (as specified in technical Specifications) to FTP server at RODC, CGWB, Region as specified in BOQ. National Data Center (NDC), Faridabad and India WRIS/ WIMS. • Data Transfer from RODC to NDC server & India WRIS/ WIMS software through internet. This data will be processed and disseminated via India WRIS/ WIMS cloud. • The processed data from India WRIS/ WIMS in the form of reports/ bulletins will be transmitted to existing National Data Centre.
2	Data maintenance	All activities pertaining to installation, data services, Operation & maintenance at the remote DWLR station will be maintained by the bidder during the warranty and maintenance period and will include a log of activities during every station visit.
3	Reports & Bulletins Storage system	Storage of all data, reports & bulletins in the proper manner and easy to access. This data will be backed up in such a way that it is not possible to lose data that has already been stored with the use of mirrored or replicated storage in such a way that no data is lost.
4	Help desk	Bidder to operate help desk to respond to queries from the purchaser. Help desk will be able to solve any problems related to data collection, processing, and dissemination to the purchaser. Help desk shall be available from 8am to 6pm, Monday – Sat.

4.0 Specifications for Data Transmission System (Telemetry)

The transmission system should be tightly integrated with the DWLR System (DAS), along with compact remote/field mounted systems consisting of sensor, data logger, modem and antenna.

- (i) The system should be watertight (IP68 for sensor & IP65 for data logger or equivalent) and impact resistant;
- (ii) The system should allow easy access for monitoring measurements without removing complete system.
- (iii) System must be power-supplied by standard lithium/ alkaline batteries for operation time of at least **two years** by one set of batteries (one transmission per day, 4 measurements per day) and must be placed in a water

resistant (IP65 or equivalent) enclosure. The replacement of batteries during five **years** warranty would be responsibility of the bidder, **at bidder's cost**.

- (iv) The system must have integrated energy management system using free programmable time slots for measurement and transmission to minimize power consumption;
- (v) The connectors should be water-tight (IP68 or equivalent).
- (vi) An alarm notification must be sent by the system via SMS to user defined phone numbers through suitable means of communication for user defined parameters. This includes battery performance (battery voltage).
- (vii) Standard USB / RS232 communication interface should be available for set up and configuration and must be easily accessible.
- (viii) Data logger shall be provided with Atmospheric Pressure sensor at individual station, & Atmospheric Pressure correction shall applied automatically on the raw water level reading from non-vented water level sensor. The details of correction procedure shall be fully documented in user manual. Provision shall be made to view and store the raw and compensated water level data along with atmospheric pressure and Water Temperature data in data logger memory.

Only compensated water level need to transmit to data base, however barometric pressure/uncompensated water levels may be stored in data logger and shall be transferred to the data base periodically.

- (ix) All measurement and set up options, data download and programming of data logger shall also be done by online session similar to all functions at site by direct connection to a PC
- (x) Data download / retrieval from remote DWLR station to central server PC via GSM &GPRS network shall be provided. The data from remote station should be in standard CSV format (as specified in technical Specifications) which is compatible with India WRIS/ WIMS software
- (xi) The software should be provided to allow download of the data from the DWLR data logger to a Laptop/hand held devices in the field.The downloaded data shall be in standard CSV format (as specified in technical specifications) which is compatible with India WRIS/ WIMS software.

5.0 Specifications for Data Processing Hardware at Data Centre

Hardware at State Data Center established for RODC, Region as specified in BOQ shall also be used for the aforesaid purposes

The purchaser will provide access to the existing Data Centre at Region as specified in BOQ. The purchaser will also provide a Local Area Network connecting the server with the other nodes on the network for analysis purposes.

The data collected at site from various DWLR stations will be stored and transmitted through GSM / GPRS telemetry and shall be received by existing GPRS & GSM receiving station at existing Data Centre at Region as specified in BOQ. Thereafter, data shall be transmitted through internet to India WRIS/ WIMS software for further processing in the form of reports /bulletins. Subsequently, India WRIS/ WIMS software will send the decoded data along with reports /bulletins to State Data Centre, through Internet and India WRIS/ WIMS cloud. Which would be required to be appropriately stored by the bidder in the already available server in state date center? The necessary automated arrangement is to be made by Bidder

Hardware at Regional Office Data Centre, Region as specified in BOQ should have following major equipment;

- a) Server with monitor as per the following specifications
- b) Necessary data switch, router and firewall for minimum8Mbps internet speed, static IP

- c) 3 KVA online UPS with 4 hours backup time
- d) Computer Node (Workstation) PC
- e) A 3 Size color Printer
- f) 42” LED Display unit

5.0 Server Technical Specification:

- a) Server having two nos. of x86 64-bit processor (Intel Xeon E5-2620 v4 or better)
- b) 64 GB DDRIII expandable to 256 GB or more
- c) Integrated Graphics Controller
- d) SAS RAID Controller supporting RAID 0,1,
- e) 2*600 GB SAS Hot Swap HDD (10 K or higher RPM),
- f) Dual 1 Gbps Network port,
- g) DVD writer,
- h) 23” LED Monitor with a resolution 1920X1080 or better,
- i) OEM Keyboard and OEM Mouse
- j) Server Chassis having Redundant Hot Swappable Power Supply with 8 Hot Swap drive bays,
- k) Certification for Linux and Windows,
- l) All required device drivers for System Configuration and Server Management Support including additional data storage facility of 8TB for 5 years and all accessories.
- m) Software: Perpetual license for window server (2012 or later), perpetual license for MS Office, firewall system with Good antivirus etc.

5.1 Computer Node(Workstation)

Operating system	Windows 10 Home/Professional
Chipset	Intel H270 and above or equivalent
Processor	Intel® Core™ i7-6700T with Intel® HD Graphics 530 (2.8 GHz, up to 3.6 GHz, 8 MB cache, 4 cores) and above or equivalent
Memory	8 GB DDR3L and above or equivalent (RAM)
Hard drive description	1 TB 7200 rpm SATA or better
Display	58.42 cm (23) diagonal WLED-backlit (1920 x 1080). Touch-enabled (optional)
Optical drive	DVD-Writer
Network interface	Integrated 10/100/1000 Gigabit Ethernet LAN
Wireless	802.11b/g/n (1x1) and Bluetooth® 4.0 combo (Optional)
Port	4 USB 2.0; 2 USB 3.0; 1 headphone/microphone combo

Pointing device	USB wired/wireless optical mouse
Keyboard	USB wired/wireless standard keyboard
Pre-installed software	Preinstalled MS Office Lifetime with Good antivirus is preferred.

5.2 Printers Specifications

A3 size color printer shall be procured for National Data Center from a reputed manufacturer.

- i. A3 color printer
- ii. Functions: Print, Copy, Scan
- iii. Printing Up to 20page/minute
- iv. Black & color printing: As fast as 9.5 sec per page
- v. Recommended monthly page volume: 250 to2000
- vi. Processor speed:600MHz
- vii. Connectivity: e Print capability
- viii. Paper handling input, standard: 100 sheet input tray
- ix) Paper handling output, standard: 100-sheet face-down bin

5.3 DISPLAY UNIT(LED)

- i. 42” LED Display unit
- ii. Display resolution: 1920 x1080
- iii. Colors: 256Kcolors
- iv. Interfaces: 1 x Ethernet (RJ45) (max. 12Mbit/s), HDMI port, USB port 1 x USB, Multimedia card /SD card slot combined.
- v. Industrial Ethernet: 1 x Ethernet(RJ45)
- vi. Protocols: Protocol (Ethernet)TCP/IP
- vii. Image formats Supported: JPEG, JPS,MPO
- viii. Sound technology: Dolby digital

6.0 GSM & GPRS Transmission of Data format to RODC, NDC, Faridabad &India WRIS/ WIMS Software:

The format for GSM / GPRS communication is as specified below

Table below gives the GSM / GPRS data parameters and their identification code format which is required to transmit the data from data logger to FTP server.

FORMAT:

&Station ID, Date and Time, Mobile Number, Battery, Water Temp, Corrected Water Level, Electrical Conductivity

Above data string will be ended with New-Line character and a separate data string will be for each measurement cycle.

Example Data Spring:

&738D1E76, 07/01/19 00:00, 9849556430, 13.5, 22.3, 26.347
 &738D1E76, 07/01/19 06:00, 9849556430, 13.5, 24.5, 26.347
 &738D1E76, 07/01/19 12:00, 9849556430, 13.5, 26.8, 26.347
 &738D1E76, 07/01/19 18:00, 9849556430, 13.5, 24.3, 26.347

Sl.No.	Channel no.	Parameter
1.	Station ID	Start of String should be '&' and Eight Characters Station ID provider by bidder
2.	Date and Time	Measurement date and Time in DD/MM/YY HH:MM in IST of the measurement cycle
3.	Mobile Number	Mobile no (10 digit) of remote station SIM
4.	Battery	Battery voltage in Volts with 1 right digit at measurement date and time
5.	Water Temp	Water Temperature in °C with 1 right digit at Measurement date and time
6.	Corrected Water Level	Water level after atmospheric pressure compensation in Mts. with 3 right digit at measurement date and time
7.	Electrical Conductivity	EC in micro Siemens/cm

Note:

1. If any sensor is not connected then it should transmit '--' characters in place of the sensor value.
2. Attached format is indicative, recommended for standardised data acquisition for development of unified Water Information System.

The Bidder is required to provide an extensive training programme for the system. The training set forth in the following paragraphs is a minimum requirement and the bidder should propose any additional training that he considers critical for long term success of the system operations.

The Bidder is expected to provide an outline or table indicating the contents of each of the required courses. The table shall describe the specific topics to be covered for each day of the training period.

The Bidder is responsible for the salaries of the training instructors and all training materials. The costs of travel, transportation and per diem for the trainees shall be borne by the Purchaser.

Training shall be provided by the bidder in several phases. The training shall include both classroom and field trainings and will be continued during all five years. The bidder is required to have DWLR equipment specialists.

7.1 The Bidder shall provide mandatory trainings as training modules as part of the Tender given as under:

S. No.	Description	Numbers of trainings	Number of Participants per session
1	Two types of trainings are to be organised. (i) Onsite training to be organised in each State where DWLRs are to be installed. Three onsite trainings for each State (ii) Training at concerned Regional Office Data Center (RODC) of CGWB. Two trainings at concerned RODC.	As specified in BOQ	15

All aspects of the electrical, instrumentation and telemetry equipment being supplied shall be covered in the courses and full documentation shall be provided. The documentation and kits shall be got approved from purchaser in advance. The course shall provide detail documentation and shall ensure that the purchaser's personnel shall be able to modify settings/ parameters without reference back to the Supplier. The places / sites where this training will be decided later by the purchaser.

The training course will take place as decided by the Purchaser. In case of formal training, the Purchaser will provide classroom and other logistics. The Bidder will facilitate the professional and the training materiel. On-the-job training will be provided by the Bidder in conjunction with the installation of the DWLRs and during the course of maintenance as required.

7.2 TA/ DA of the trainees shall be borne by the purchaser.

7.3 Training kit containing course material in soft as well as hard copy shall be provided by the Bidder.

7.4 All logistical arrangement such as projector, training space etc. for training is to be made by purchaser

8.0 PREVENTIVE MAINTENANCE

The bidder shall be responsible for operation and maintenance of all stations /components of installations, commissioning, site acceptance and operation tests. All equipment maintenance cost, repairs, replacements and

repairs to civil work shall be borne by the bidder during the warranty AMC Period. The scope of O&M support would include all materials and services including replacement of components, and consumables (batteries etc.) mandatory spare parts required to ensure smooth and sustainable operations of the entire system. The bidder shall provide monthly maintenance reports during the course of maintenance. The bidder shall supply a Manual specifying all the faults experienced by the system together with an account of how such faults have been rectified. Bidder shall provide the list of mandatory spare parts & shall ensure the availability of sufficient mandatory spare parts in its godown for fulfilling its service obligations during warranty and AMC period. The same can be inspected by Engineer-in Charge or its authorized representative.

The bidders shall ensure the following visits at remote site for preventive maintenance. The bidder should take time stamped geo tagged photographs of the equipment during each maintenance visit (either scheduled or unscheduled visit). The photographs should show the condition of equipment before maintenance, during maintenance and after maintenance.

SCHEDULE SHOWING FREQUENCY OF SCHEDULED VISITS FOR ROUTINE AND PREVENTIVE MAINTENANCE

Sl. No.	Station Category	Minimum Annual Preventive Visits	Remarks
1	DWLR stations	4	Every Half yearly and also on need basis

8.1 Operation & Maintenance

- Bidder shall provide at least one Service Engineer cum operator at the Regional Office Data Center for Operation of DWLR system and ensure seamless data transfer from remote stations to Regional & National Data Center (NDC), CGWB, Faridabad FTP server through GSM/GPRS network & from RODC to NDC & India WRIS/ WIMS software through internet. And also the processed data from India WRIS/ WIMS in the form of reports/ bulletins will be transmitted to Regional & National Data Centre which should be stored in a proper manner and easy to access.
- Operation and Maintenance shall include free of cost repairs/ replacement of hardware and Software necessary to keep the system functional for the period of five years from Date of Installation, and further during 2 years of AMC.

TECHNICAL RESPONSIVENESS FORM

Bidder shall furnish clause by clause commentary against the laid down technical specification and standards as per the format given below:

(A) Summary of Instructions

- i. Particulars of Manufacturer and local agent cum representative are to be given under rows Model and Address.
- ii. All entry boxes in column “**Specification and Standards as offered in by Bidder**” shall be filled-in accurately and comprehensively. Quantitative fields shall be filled in accurately. It is not acceptable to use ‘Yes’, No, Compliant or similar evading words. Following format is designed to help the Bidder to understand the requirements of the equipment being procured. The Bidder must describe in the format how his bid responds to the technical requirements of the equipment. Bidder to note that one or two word responses (e.g. “Yes”, “No” “will comply” or similar evading words) are normally not sufficient to confirm the responsiveness with the technical requirements, hence elaborate responses are sought from the bidders. **In case deviation on the following technical requirements of equipment is not as per the minimum criteria mentioned, the bids may be declared “non-responsive”.**
- iii. Requested materials and information shall be enclosed with the bid and be unambiguously associated with instruments as offered in the bid
- iv. Negligence to comply with the instructions and requirements as stated above makes the bid liable to be rejected.
- v. Abbreviations: OD-Outer Diameter; ID-Inner Diameter; FS-Full Scale; Pa-Pascal (unit of pressure), DWLR-Digital Water Level Recorder; DRS-Data Retrieval System; HHT-Hand Held Terminal, DCP- Data Collection Platform, AWLR- Automatic Water Level Recorder.
- vi. Sample interval is the interval at which samples or sensor readings are taken. The recording /measurement interval defines the interval at which the data records are stored in memory. A data record can represent a single sample or the average of a number of samples. In particular the result of the wave suppression filter is a single record representing the average value of a number of samples.

B) Entries requiring special attention:

- (i) The longitudinal properties of the suspension cable affect the accuracy directly. Bidder to specify all factors affecting the longitudinal properties of the suspension cable: e.g. length creeps due to sensor and cable weight (submerged) longitudinal temperature coefficient, uncoiling after installation, expansion/contraction of jack due to temperature and aging, etc.

(C) Bidder shall provide information in the formats given below:

- (i) Make/ Model/ Local Agent etc.:

Bidder	DWLR Sensor with EC probe make/ model	Data Logger make/ model	Local Agent
Name / Complete Address/Website/Email	Model: Manufacturer: Name: Place: Tel: Fax: E-mail: Web:	Model: Manufacturer: Name: Place: Tel: Fax: E-mail: Web:	Name: Address: Tel: Fax: E-mail: Web:

- (ii) Clause by Clause Commentary against laid down technical specifications:
Specifications of the DWLR, hydrostatic Type (GW) with telemetry system

Name of Goods-Its Features	Required Specifications and standards as per bidding document	Specification and standard as offered in by Bidder	Remarks
Site Conditions			
Ambient Temperature	From 0 to 60 degree		
Humidity	5-100 %		
Altitude	0- 2500 meter		
DWLR -- Water level, Temperature and EC Sensor		<u>Make:</u> <u>Model No:</u> <u>Manufacturer Name, address, email, phone, website, fax</u>	
Sensor Type	Submersible pressure transducer with Non-Vented Pressure Sensor with Barometric Pressure Correction for Individual Sensor. Sensor should measure Ground Water level, Ground Water temperature and Electrical Conductivity		
Range	(30m, 60m, 120m, 200m, 300m)		
Installation Depth (Cable length)	As per the attached list		
Dimension	Outer diameter of sensor unit: < 80mm, (for sensor)		

Material	stainless Steel (SS-316) or other better corrosion resistant material		
Ingress Protection	IP68 for sensor		
Overall Accuracy	0.2% FSO		
Resolution	3 mm		
Reproducibility	0.1% full scale or better		
Long Term Stability	0.1% Full scale and should ensure long term stability without any field calibration requirements except barometric compensation		
Temperature Measuring Range	0 to 50°C		
Temperature Measuring Accuracy	Better than $\pm 0.3^\circ\text{C}$		
Burst Pressure	≥ 2 Time Full scale		
Overload Pressure	1.5 Time full scale without effect on calibration		
Over-voltage Protection on supply & sensor wires	Should include lightening, over-voltage and surge protection		
Electrical Conductivity Sensor:			
Sensor Type	Balanced –electrode cell		
Range	5 $\mu\text{S/cm}$ to 100,000 $\mu\text{S/cm}$ (0.005mS/cm to 100 mS/cm)		
Accuracy	$\pm 0.5\%$ of measurement value or (min. ± 10 $\mu\text{S/cm}$)		
Resolution	1 $\mu\text{S/cm}$		
Pressure Rating	Up to 350m water depth		
Note- The output of the Electrical Conductivity Sensor will be integrated with datalogger at Selected DWLR site, Bidder may offer combine Water Level, Temperature and Electrical Conductivity sensor or separate combination of sensors			
General			
Output	SDI-12, RS-485, 4-20 mA or compatible with data logger.		
Installation	The system should be provided with a		

	suspension bracket , Well enclosure /canopy & junction boxes (if required) allowing secure installation within the Piezometers' headwork, including appropriate cable mounting accessories to allow the sensor to be adjusted to the required depth.		
Direct Read Sensor Cable	<p>The cable shall have following features:</p> <ul style="list-style-type: none"> • Strength members for good longitudinal stability of cable • The cable and contacts should be fixed or quick connect • Cable screen to be connected to the data logger ground terminal to minimize electrical interference. • A cable suspension bracket allowing the DWLR to be adjusted to the required depth, in a stable and reproducible manner. • Corrosion and moisture free as the equipment has to work under water condition. • Cable should have good flexibility. • Should be of Polyurethane Jacket or better. The electrical wires shall have sufficient conductivity to allow for extension of the cable to up to 200m without degrading accuracy, stability and data communication. 		
DWLR Data logger		<u>Make:</u>	
		<u>Model No:</u>	
		<u>Manufacturer Name, address, email, phone, website, fax</u>	
Atmospheric Pressure correction	Atmospheric Pressure corrections to be applied automatically		
Resolution of measurement	16-bit ADC with +/- 1 LSB accuracy (1 mm or better)		
Measuring interval	Should be programmed to store data from 1 minute one reading to 24 hours one reading.		
Settling up Time	< 30 minutes after submersion.		
Recording Capacity	Shall store the data for at least 1 year		

Memory Type	Non-Volatile flash memory that can store one year of data (with 15minute logging interval) & expandable up to minimum 1 GB using USB/SD Card		
Power Supply	Should be equipped with lithium or alkaline battery pack, giving at least 2 years operation (with one transmission and four recordings per day). Battery must be replaceable in the field or in local offices of the implementing Agency or supplier. Replacement of batteries must be readily available in India.		
Battery Voltage Monitoring	Monitoring and transmission of Battery Voltage level		
Built in clock	Accurate to ± 1 minute per Year		
Displayed time resolution	1 second or better		
Protection	IP68 with Impact Resistant for Water level sensor IP65 (for data logger) with Impact Resistant		
Port for configuration	One serial / USB port for communication with laptop for programming		
Ports for telemetry	Port for communication with GSM &GPRS telemetry		
Operating System	Windows based software for system configuration / communication		
Licenses	All required licenses shall be included		
Real time clock	Time synchronization facility shall be provided with IST		
Accessories	Serial cable and adaptor if required along with all accessories and fixing units etc.		
Communication Interface			
Computer Interface	The Logger must be capable of connection to a computer via USB 2.0/USB 3.0 and supply should include the necessary interface cables.		
File Format	The format of the data downloaded by communication interface shall be in standard CSV format (as specified in technical Specifications) which is compatible with India WRIS/ WIMS software.		
GSM &GPRS Transmitter		Make:	
		Model No:	

		<u>Manufacturer Name, address, email, phone, website, fax</u>	
Transmission System	GSM/GPRS/edge-based data transmission system		
Frequency range	900 MHz: 824-960 MHz/1800MHz:1710-1880 MHz 4G andbetter		
Performance	Data Reception availability of 95% or better		
Communication Direction	Utilize GPRS network for two-way connection with connection with FTP, TCP/IP (INTERNET) connection and SMS server		
Transmission trigger	Data collection to be triggered by interrogation from Data Center, or by event-based transmission triggered by remote site		
Power Saving	Ability to disable interrogation system in order to save power at remote site		
Communication Protocol	Data transmission to execute HTTP Post or FTP, SMS to transmit data to the Data Center		
Accessories	All associated equipment, including Antenna all cables and mounting hardware		
Software for Data logger			
Operating System	Windows based software for system configuration, transfer and analysis of data to computer		
Version	English language version		
License	All required licenses included		
General Features			
Battery	The battery should be easy to replace, and easily available in the market.		
Tools	Complete tool kit for installation and routine maintenance		
Manuals	Full documentation and maintenance instructions in English		
Training	As per mutual consent at the time of installation of telemetry system		
GSM / GPRS transmission format	As specified in the technical Specification table for GSM /GPRS communication format		

Specifications of Data Acquisition Software (DAS):

SI	Required Specification and Standards as per Bidding Document	Specification and Standards as offered in by Bidder	Remarks
1	<p>Data collection performance :</p> <p>Bidder should ensure seamless data and responsible for</p> <ul style="list-style-type: none"> • Real-time data collection at all DWLR stations& shall ensure seamless data transfer. • The data from DWLR stations will be transmitted through GSM/GPRS in the standard CSV format (as specified in technical Specifications) to FTP server at the Regional office data centre, Region as specified in BOQ • From RODC, the data will be transmitted to NDC, Faridabad &India WRIS/ WIMS software through internet. This data will be processed and disseminated via India WRIS/ WIMS cloud. <p>The processed data from India WRIS/ WIMS in the form of reports/ bulletins will be transmitted to RODC, Region as specified in BOQ& National Data Centre, Faridabad.</p>		
2	<p>Data maintenance :</p> <p>All activities pertaining to installation, data services, Operation & maintenance at the remote DWLR station will be maintained by the bidder during the warranty and maintenance period and will include a log of activities during every station visit.</p>		
3	<p>Reports & Bulletins Storage system: Storage of all data, reports& bulletins in the proper manner and easy to access. This data will be backed up in such a way that it is not possible to lose data that has already been stored with the use of mirrored or replicated storage.</p>		
4	<p>Help desk :</p> <p>Bidder to operate help desk to respond to queries from the purchaser. Help desk will be</p>		

	able to solve any problems related to data collection, processing, and dissemination to the purchaser. Help desk shall be available from 8am to 6pm, Monday – Sat.		
--	--	--	--

Specifications for Data Transmission System:

Sl. No:	Required Specification and Standards as per Bidding Document	Specification and Standards as offered in by Bidder	Remarks
	The transmission system should be tightly integrated with the DWLR System, along with compact remote/field mounted consisting of sensor, data logger, modem and antenna and other accessories complete.		
1	The system should be watertight (IP68 for sensor & IP65 for data logger or equivalent) and impact resistant;		
2	The system should allow easy access for monitoring measurements without removing complete system.		
3	System must be power-supplied by standard lithium/alkaline batteries for operation time of at least two years by one set of batteries (one transmission per day, 4 measurements per day) and must be placed in a water resistant (IP65 or equivalent) enclosure. The replacement of batteries during five years warranty and two years of O&M would be responsibility of the bidder, at bidder's cost.		
4	The system must have integrated energy management system using free programmable time slots for measurement and transmission to minimize power consumption;		
5	The connectors should be water-tight (IP68 or equivalent).		
6	An alarm notification must be sent by the system via SMS to user defined phone numbers through suitable means of		

	communication for user defined parameters. This includes battery performance (battery voltage).		
7	Standard USB/RS232 communication interface should be available for set up and configuration and must be easily accessible.		
8	Data logger shall be provided with Atmospheric Pressure sensor at individual station, & Atmospheric Pressure correction shall applied automatically on the raw water level reading from non-vented water level sensor. The details of correction procedure shall be fully documented in user manual. Provision shall be made to view and store the raw and compensated water level data along with atmospheric pressure and Water Temperature data in data logger memory		
9	All measurement and set up options, data download and programming of data logger shall also be done by online session similar to all functions at site by direct connection to a PC		
10	Data download / retrieval from remote DWLR station to central server PC via GSM &GPRS network shall be provided. The data from remote station should be in standard CSV format (as specified in technical Specifications) which is compatible with India WRIS/ WIMS software		
11	The software should be provided to allow download the data from the DWLR data logger to a Laptop/hand held devices in the field. The downloaded data shall be in standard CSV format (as specified in technical specifications) which is compatible with India WRIS/ WIMS software.		

Specifications of Data Server		<u>Make:</u> <u>Model No:</u> <u>Manufacturer Name, address, email, phone, website, fax</u>	
S. No:	Required Specification and Standards as per Bidding Document	Specification and Standards as offered in by Bidder	Remarks
1.	<p>Server having two nos. of x86 64-bit processor (Intel Xeon E5-2620 v4 or better), 64 GB DDRIII expandable to 256 GB or more, Integrated Graphics Controller, SAS RAID Controller supporting RAID 0, 1, 2*600 GB SAS Hot Swap HDD (10 Kor higherRPM), Dual 1 Gbps Network port, DVD WRITER,</p>		

	<ul style="list-style-type: none"> • 23" LED Monitor with a resolution 1920X1080 or better, • OEM Keyboard and OEM Mouse, • Server Chassis having Redundant Hot Swappable Power Supply with 8 Hot Swap drive bays, • Certification for Linux and Windows, • All required device drivers for System Configuration and Server Management Support including data storage facility of 8TB for 5 years and all accessories and • Perpetual license for window server (2012 or later), perpetual license for MS Office, firewall system with Good antivirus etc. 		
--	--	--	--

Specifications of Computer node (Workstation)		<u>Make:</u> <u>Model No:</u> <u>Manufacturer Name, address, email, phone, website, fax</u>	
Required Specification and Standards as per Bidding Document		Specification and Standards as offered in by Bidder	Remarks
1	Windows 10 Home/Professional		
2	Intel H270 and above or equivalent		
3	Intel® Core™ i7-6700T with Intel® HD Graphics 530 (2.8 GHz, up to 3.6 GHz, 8 MB cache, 4 cores) and above or equivalent		
4	8 GB DDR3L and above or equivalent (RAM)		
5	1 TB 7200 rpm SATA or better		
6	58.42 cm (23) diagonal WLED-backlit (1920 x 1080). Touch-enabled (optional)		
7	DVD-Writer		
8	Integrated 10/100/1000 Gigabit Ethernet LAN		
9	802.11b/g/n (1x1) and Bluetooth® 4.0 combo (Optional)		
10.	4 USB 2.0; 2 USB 3.0; 1		

	headphone/microphone combo		
11.	USB wired/wireless optical mouse		
12	USB wired/wireless standard keyboard		
13	Preinstalled MS Office Lifetime with Good antivirus is preferred.		
10.	4 USB 2.0; 2 USB 3.0; 1 headphone/microphone combo		
11.	USB wired/wireless optical mouse		
12	USB wired/wireless standard keyboard		
13	Preinstalled MS Office Lifetime with Good antivirus is preferred.		

Specifications of Color printer	<u>Make:</u> <u>Model No:</u> <u>Manufacturer Name, address, email, phone, website, fax</u>	
Required Specification and Standards as per Bidding Document	Specification and Standards as offered in by Bidder	Remarks
A3 Size color printer		
Functions: Print, Copy, Scan		
Printing Up to 20 page/minute		
Black & color printing: As fast as 9.5 sec per page		
Recommended monthly page volume: 250 to 2000		
Processor speed: 600MHz		
Connectivity: e-Print capability		
Paper handling input, standard: 100sheet input tray		
Paper handling output, standard: 100-sheet face-down bin		

Specifications of Display Unit (LED)	<u>Make:</u> <u>Model No:</u> <u>Manufacturer Name, address,</u> <u>email, phone, website, fax</u>	
Required Specification and Standards as per Bidding Document	Specification and Standards as offered in by Bidder	Remarks
Screen Type : 42" Screen LED		
Display resolution: 1920 x 1080		
Colors: 256K colors		
Interfaces: 1 x Ethernet (RJ45) (max. 12Mbit/s), HDMI port, USB port 1 x USB Multimedia card / SD card slot combined		
Industrial Ethernet : 1 x Ethernet (RJ45)		
Protocols: Protocol (Ethernet) TCP/IP		
Image formats Supported: JPEG,JPS,MPO		
Sound technology : Dolby digital		

4. Drawings

Not required in this tender

5. Inspections and Tests

The following inspections and tests shall be performed:

General:

1. After manufacture, the supplier shall get each equipment/item of Goods inspected in manufacturer/s works as per approved datasheets and QAP and forward to the Purchaser along with his letter seeking to inspect an equipment/item of Goods conform to contract specifications.
2. Upon receipt of the test certificate and calibration certificates, the purchaser or its representative shall arrange for inspection and/or test of any or part or all the equipment/Goods prior to issuance of dispatch clearance. In cases where the supplies are received from abroad, the purchaser may waive the pre-dispatch inspection.
3. However, the inspection and dispatch clearance by the Purchaser or the waiver thereof shall not prejudice the right of the Purchaser or its consignee to test the equipment/goods on receipt at destination. Upon receipt of the goods at final destination, the Purchaser shall have the right to inspect and/or test the equipment/Goods to confirm their conformity to contract specifications.
4. If the equipment fails to meet the contract specifications during inspection, whether pre dispatch or upon receipt of at final destination, the supplier shall take immediate steps to remedy the deficiency or replace the defective equipment to ensure that all supplies meet with the specifications specified in the contract

Inspection and tests prior to shipment of Goods and at final acceptance are as follows:

1. The inspection of the Goods shall be carried out to check whether the Goods are in conformity with the approved technical specifications attached to the contract and shall be in line with the inspection/test procedures laid down in the Technical Specifications and the General Conditions of contract. Following broad test procedure will generally be followed for inspection and testing of instruments. The supplier will dispatch the goods to the ultimate consignee after internal inspection testing along with the supplier's inspection report and manufacturer's warranty certificate based on the inspection waiver from purchaser. The purchaser will test the equipment after completion of the installation and commissioning at the site of the installation.
 - a. Site Preparation and Installation: The Purchaser will designate the installation sites before the scheduled installation date to allow the Supplier to perform a site inspection before the installation of the DWLRs and associated telemetry system. In case there is a delay in handing over the site by the purchaser, appropriate extension of time shall be granted without imposition of liquidated damages in accordance with the provisions of contract.
 - b. For site preparation, the supplier should furnish all details (installation drawings) to the purchaser sufficiently in advance so as to get the works completed before receipt of the equipment.
2. Complete hardware and software as specified in 'List of Goods and Delivery Schedule' Under the Schedule of Requirement should be supplied, installed and commissioned properly by the supplier prior to commencement of performance tests.
3. The acceptance test will be conducted by the purchaser/their consultant or any other person nominated by the purchaser, at its option. The acceptance will involve **trouble-free operation for seven consecutive days**. There shall not be any additional charges for carrying out acceptance tests. No malfunction, partial or complete failure of any part of hardware attached to printers, drivers etc. or bugs in the software should occur. All the software should be complete and no missing modules/sections will be allowed. The supplier shall maintain

necessary log in respect of the results of the tests to establish to the entire satisfaction of the purchaser, the successful completion of the test specified. An average uptake efficiency of 90% for the duration of test period shall be considered as satisfactory.

4. In the event of the hardware and software failing to pass the acceptance test, a period not exceeding two weeks will be given to rectify the defects and clear the acceptance test, failing which the purchaser reserves the rights to get the equipment replaced by the supplier at no extra cost to the purchaser.
5. DWLRs procured would be subject to the Acceptance Protocol given below

ACCEPTANCE PROTOCOL

1. General

- a. The delivery of goods/equipment and software should be in accordance with the contract agreement and the process of delivery will adhere to the following 'Acceptance Protocol'. The Acceptance Protocol shall serve as a formal guidance during delivery of the DWLRs. Its primary goals are twofold.
 - i. Ascertain the delivery and completeness of all ordered products and related documents.
 - ii. Check the functioning of the equipment and software in a formal way against the specifications by application of Acceptance Tests. The tests also verify the accuracy and stability of the equipment.
- b. The Acceptance Protocol shall be executed in close co-operation between the Supplier and the Client.
- c. Products shall be accepted only if they meet the requirements and are functioning in compliance with the technical specifications, and the related documents are complete and correct. Defective products and any other discrepancies shall have to be replaced/resolved, within a pre-defined time frame as specified in bid document.

2. Documents

- a. The following documents shall accompany the delivery of the instruments and software:
 - i. Administrative and Quality Assurance (QA) documents
 - ii. Test and calibration documents
 - iii. Manuals and Guidelines

All documents shall have identification and references to subject or instrument, date, time, location and officer in charge.

- b. The Acceptance Report lays down the findings and observations during the execution of the Acceptance Protocol and is a formal document to record the acceptance or rejection of any item as covered in the Bid document. Any flaws or findings are to be reported. The forms and checklists filled out during the execution of the Acceptance Protocol are to be enclosed with the Acceptance Report. The Supplier receives a signed copy of the Acceptance Report, which the Supplier can use as proof that the items listed in the report were accepted.
- c. The content of the various documents shall be as follows:

2.1 Administrative and QA documents: These QA documents shall include:

- i) Production documents associated with the instruments.
- ii) Type codes, serial numbers and other identification data on, possibly externally procured, sensors and major assemblies, to clearly demarcate the sensors/major assemblies associated with each DWLR.
- iii) Shipping documents indicating instrument/product type, serial number, measuring range, cable length and other similar data.

2.2 Test and calibration documents:

- i) A comprehensive Method Statement on the applied calibration and in-factory test procedures shall accompany the bid. The Method Statement should define the test and calibration methods applied on the instruments and the components thereof. The Method Statement shall also include, for each calibrated product, an audit trail to national standards on all instruments and facilities used for testing and calibration. The Audit Trail Report shall associate the calibration of the reference instruments and test equipment to the national calibration standards.
- ii) If the Supplier or Manufacturer is not in a position to deliver an Audit Trail Report to the national standards, the Manufacturer shall explain what the quality standards are and how they are maintained and monitored.
- iii) Conditions during calibration, such as room and/or instrument temperature, equipment and facilities used, shall be included in the calibration and test documents.

- iv) The test and calibration documents shall contain the data generated during calibration and testing, including:
- Calibration data supplied by the Manufacturer of pressure sensor
 - Calibration and test data of the data-logger electronics
 - Calibration data on overall DWLR calibration, i.e. comprising both pressure sensor and electronics. A table listing applied reference pressures versus instrument readings is to be delivered for each sensor and instrument. Furthermore, that table shall also show the test conditions during calibration
 - Data on hysteresis test, temperature tests, zero stability test, scale stability test
 - Humidity test, in particular for non-vented gauge pressure sensors
 - Temperature cycling of sensor and electronics
 - Spray test on enclosure(s), connectors and cables

2.3 Manuals and Guidelines

- i) The manuals shall meet the requirements on style and clarity, completeness, preciseness, detail and accessibility. This includes:
- System manual,
 - Operation, Maintenance and Service manuals,
 - Observation guideline, and
 - Training handouts.

3. Acceptance Tests

1. General

- i) Qualified engineers under responsibility of a test manager shall execute the Acceptance Tests. The progress of the Acceptance Tests would be monitored and supervised by the Client and/or his authorised representative. The Client may have any tests redone or additional tests executed as deemed required based on the results of previous tests conducted. The Client's and/or his authorised representative shall have the right of access to any instrument and may request any data or information at any time. The Supplier has the obligation to deliver requested information without delay; i.e. collected test data and documents must be available at the test site.
- ii) It is important that all activities (what, when, where, who, which instrument, etc.) are annotated and uniquely linked to the individual instruments.
- iii) The Acceptance Tests mainly comprise three levels viz.:
- Functional Tests: The Functional Tests shall verify the proper functioning of the instruments and the associated software. Primary goal is to verify that the instrument performs its functions according to the bid specifications.
 - Accuracy Tests: The Accuracy Tests shall verify that each individual instrument is functional and operates according to the bid specifications. A number of relatively simple accuracy tests are routinely exercised on the instruments.
 - Overall Test: The main purpose of the Overall Test is to verify the common features that are identical to all the instruments in a series. Typical components of the Overall Test are: - in-built software functions, materials of the instrument, cables, connectors, etc. Further tests include battery and memory autonomy, details of sensor specifications like temperature effects, hysteresis, long term stability etc.
 - The above tests can be executed at any one of the following locations:-Premises of the Manufacturer/Supplier; Premises of the Client; Independent organisation; at Site of installation
- iv) The charges for testing shall be borne by the Manufacturer/Supplier. The Client and/or his authorised representative may at his cost opt to be present during the performances of the tests.
- v) If the tests are executed at the Client's premises, the charge for testing shall be borne by the Client and the Supplier shall be responsible for conducting the tests. The bidder in his bid shall indicate the name of independent organisation and the charges for testing. The Client reserves the right to accept the independent organisation and its charges or get the tests done by any other agencies. However, the Supplier would be permitted to be present at these tests.
- (Explanatory Note: Test report from manufacturer would be acceptable. In case purchaser desires to test the system from independent agency (ies), testing charges would be borne by purchaser.)
- vi) The details of these tests are as follows.

1.1. Functional Tests: The Functional Tests include: visual inspection, and user tests.

1.1.1 Visual Inspection: Visual inspection includes the following activities.

- i) All items are visually checked for damage, e.g. on cables, sensor and housing.
- ii) Availability of non-removable identification codes and specifications are verified, e.g. serial number, type identification, manufacturer and measuring range.
- iii) Cables have to be marked: each cable is to have an identification code and name.
- iv) Cable connectors shall have their ends marked suitably to indicate the device to which it is to be connected, e.g. PC, HHT, Power Supply etc. Suitable precaution shall be taken so that the connectors are not connected to wrong terminals, i.e. it shall be impossible to connect a power cable to a communication bulkhead socket.

1.1.2 User tests

- i) All instruments have to be identical except for measuring range, cable length, identification code and similar aspects. Consequently, there is no need to check the functionality of all systems. It is assumed that the functional compliance with the specifications is tested under the Overall Tests. The objective of the user test is to detect any malfunction and/or defect. From practical point of view, the user tests can be coupled with other test, e.g. the stability tests.
- ii) Basic functions to be tested are:
 - Pre-deployment preparation, e.g. setting of clock, erasing of memory, setting data logging parameters, entry of identification data
 - Facilities for execution of on-site functional checks
 - Data retrieval and data transfer to PC
 - Battery status and voltage
 - Simple output test by observing pressure reading while the sensor is immersed in a bucket filled with water

1.2 Accuracy Tests: The Accuracy tests include:

- accuracy tests on clock, and
- accuracy tests on pressure measurement

1.2.1 Accuracy tests on clock

- i) The clock of the data logger shall be carefully checked against national time, e.g. taking the radio broadcast time beeps as a reference. The data logger clock is set precisely and checked at the start of the individual tests and upon instrument and/or data retrieval. In between, the clock should not be readjusted.
- ii) The clock test shall cover at least 3 days to get sufficient time resolution. The reference clock, e.g. a watch, must be carefully tuned against national time prior to and during the tests. The clock drift, converted to seconds per month (31 days) shall comply with the defined specifications. This test method makes use of the specified time resolution of 1 s.

1.2.2 Accuracy tests on pressure measurement

- i) The accuracy test on the pressure sensor is an overall accuracy test covering both the pressure and electronics systems. The pressure tests are to be executed against accurately known reference pressure(s). Pressure can be generated from compressed air (gas) or by submerging the sensor to known depths in water.
- ii) Reference pressure may be created via a precision pressure reduction valve from a source of compressed air. A high precision sensor like a Digital Quartz pressure sensor or a Dead Weight Tester can be implemented to quantify the applied pressure. Pressure should be measured in KPa (or mbar).
- iii) When applying the immersion method it is much more difficult to check the instruments because water density affects the reading. Moreover, it is not simple to establish the exact depth of sensor immersion. And especially in narrow wells, while immersing a pressure sensor on its cable into a well, the water level will rise due to the additional volume of the immersed pressure sensor and cable. The water level will gradually fall again, when the well level adjusts again to equilibrium with the ground water level. In order to achieve a high accuracy these effects have to be assessed.
- iv) The pressure sensor tests include:
 - Zero stability test
 - Scale test
 - Scale stability test
- v) The pressure sensor tests shall focus on temperature effects on zero, scale and cable length, and in addition to that establish quantitative data on drift of zero, scale and creep of cable length.

1.2.2.1 Zero stability test

- i) During the zero-test the instruments are in logging mode, say at an interval of 30 minutes, and shall be kept in a separate room where they will not be touched for at least 3 days. The instruments must be dry, i.e. not in a bucket of water, to exclude any water effect on the sensor, and hence, the instrument reading is expected to be 0.0.
- ii) Under this test, each instrument will record its short term zero drift and inherently the effectiveness of the air-pressure compensation method. During the zero-test, the instruments shall be in the same and constant position, vertical or horizontal. The room temperature shall vary over 5 °C or more, e.g. due to daily temperature fluctuation, this to assess temperature effects on the instrument reading. This requirement may affect the choice of venue for the zero-tests. To avoid any adverse temperature strain, no direct sunlight shall fall on the instruments. At the end of the test, the collected data are offloaded from the data logger memory and analysed for zero stability. As the instruments are kept in air and are not touched, the reading shall be stable and not change over time that is not beyond permissible limits.
- iii) Room temperature is to be logged against time, preferably by digital method. In case the DWLR has a built-in temperature sensor, that sensor may be used for temperature logging. The pressure sensors shall not be tested in an air-conditioned room for several reasons. First, temperature fluctuations may be so rapid that the sensor temperature compensation scheme may not be able to cope with it. Moreover, rapid air-pressure fluctuations may not be handled properly by the air-vent system and/or the pressure measurement method. This is to be understood from the perspective that the instruments are designed to operate in wells where changes occur but not rapidly. One or more fans may be operated continuously to minimise temperature gradient across the test room.
- iv) To test the creep and elongation of the electrical cum suspension cable some vertical open space is required, e.g. a stairwell can be used for this purpose. However, it is important that the cable is protected against touch to avoid interference with the measurements. The cable is loaded with some weight to emulate the weight of cable and sensor. The length of cable under tests shall be as long as possible, i.e. 10 m or more, to get the best accuracy of the tests. The lowest point is suspended to about 0.15 m above the floor. The gap between lowest point and floor is monitored against time. Initially readings are taken every 30 minutes for 12 hours, subsequently the reading interval may be increased to 6 hours. The cable test shall be executed during 7 days. Resolution of measurement should be 1 mm or better. The result is to be presented in mm length change per meter suspended cable length. Only one cable is to be tested.

1.2.2.2 Scale test: A precisely known pressure is applied on the instrument and the instrument reading is taken. The instrument reading is converted into level or pressure whatever is applicable. The calculated value is compared with the applied value; the difference is regarded as the FS error. In case the specifications of the applied pressure sensor may give reason to doubt the instrument's linearity, then a mid-scale test is to be executed as well.

1.2.2.3 Scale stability test: Scale stability is tested by subjecting the instrument to the full-scale pressure for at least 24 hours. During the test, the applied pressure/level is to be accurately monitored by taking reference readings either by a reference logger of high accuracy or by manual readings. The accuracy and resolution of the reference measurement must be 1 mm water column or 0.01 kPa (0.1 mbar).

1.3 Overall Test: Part of the Overall Test is also covered under the Functional Tests and Accuracy Tests. The Overall Test comprises tests on:

- autonomy
- fitness for environment
- functionality
- calibration
- stability
- reproducibility, and
- main power failure

Details of the various tests are as follows.

1.3.1 **Autonomy:** Two autonomy tests shall be conducted:

- battery capacity versus the power consumption per measurement, and
 - memory capacity
- i) **Battery autonomy test:** To execute the test, the instrument is set to a fast data collection interval and the capacity, i.e. the number of samples, is established by a continuous process of data collection until the batteries are depleted. The test shall be executed on new batteries. In this context, the batteries are deemed depleted when the instrument stops functioning because the battery voltage watch-dog function detects a too low battery voltage or the normal operation of the instrument stops.
 - ii) **Memory capacity verification:** The memory is filled at the highest data-recording rate and the volume of collected data is verified against the bid specification. This test could be combined with the battery autonomy test and the samples are taken at a high rate to minimize the test duration.

1.3.2 Fitness for environment

- i) Connectors, cable glands, cables and housing must be suitable for the environment of operation, be it submersed, in a well or above the ground. Water ingress can be assessed by visual inspection and / or by insulation measurement. Visual inspection may only reveal ingress of a significant amount of water. The insulation measurement is more sensitive, especially for cables, connectors and encapsulated electronics, but requires specialised equipment.
- ii) The above-surface components have to be compatible with IP65 standard and shall be tested accordingly by exposing them to a heavy shower for 3 minutes. Subsequently the ingress of water is assessed by opening of the instrument and connectors.
- iii) The submersible components must comply with IP68 standards. To verify this, the instrument shall be suspended in a well for at least one week, to a maximum depth, without affecting the calibration of the pressure sensor and not exceeding 2 times the rated measuring range. Although most pressure sensors can withstand considerably more than 2 times the rated measuring range, there is no need to exceed this. Prior to this test, the zero and scale of the sensor have to be established and verified again upon recovery.

1.3.3 Functionality

- i) Functionality has to be verified for all requirements for operation of the DWLR with reference to the bid specifications and the instrument specifications as given by the Manufacturer. Missing functionality shall be reported.
- ii) All (software) functions as stated in the instrument manual(s) and the instrument specifications are tested for correct functioning. Any detected flaws are reported which shall be repaired/rectified by the Manufacturer/Supplier within seven days.

1.3.4 Calibration

- i) The instrument calibration is checked for compliance with the bid specifications. In particular accuracy, stability, linearity, hysteresis and reproducibility are verified.
- ii) The scale or sensitivity of the complete instrument, including sensor and electronics, is to be checked for at least 11 pressures, equally distributed over the full measuring range. Furthermore, the calibration data as delivered with the instrument are verified for accuracy and consistency with data obtained from the calibration tests. The calibration may be executed by application of accurately known air-pressure or by immersion in a well. The temperature effects on the calibration should also be verified at low, mid and maximum range temperatures.
- iii) **Note:** Prior to execution of immersion tests, the effective position of the sensor membrane relative to the sensor housing is to be assessed and measured, e.g. by execution of a bucket experiment. In this experiment, the sensor is partly immersed in a water filled bucket to a depth where the related reading has changed by several centimetres, relative to the 'in-air' reading. During the test, the position of the water surface on the sensor's body shall be observed and marked accordingly. The 'effective-sensor-zero' lies below the water surface during the test. The position of the effective-sensor-zero is below the above mentioned water-surface mark by the equivalent of the sensor reading expressed in centimetres. The effective-sensor-zero may be close to the sensor membrane but not necessarily coincides with it.

1.3.5 **Stability:** Stability related to the DWLR is defined as a variation over time of the instrument specifications, whereas the circumstances and pressure do not vary. Parameters to be checked are:

- zero: offset stability
- scale: full scale stability
- cable: length (extension/contraction) and creep stability

The methods to assess these stability factors are explained under the section on Accuracy Tests.

1.3.6 **Reproducibility:** The sensor reading in air is annotated, subsequently the sensor is immersed to the rated measuring depth, and a stable reading is collected. Then the sensor is recovered to the surface and again a stable reading is taken. This process is repeated 5 times and results are duly annotated. It is important that during the complete test the instrument is kept in the same, vertical position.

1.3.7 Main power failure:

- i) Some instruments operate on replaceable batteries or even external power and have a built-in back-up facility, usually based on a Lithium battery. It is quite possible that on some instruments the external power supply or the replaceable batteries fail because of total depletion, disconnection, defect on the cable or connector etc. In such an event, the instrument must retain its clock, its program setting and most importantly all the collected data.
- ii) The Functional Tests are executed in conjunction with the stability test. Upon finalising these tests and after successful retrieval of all test data the power is disconnected by removing the main power batteries and/or disconnecting

the power cable. The instrument is to be left in that state for at least 24 hours. Then the power shall be connected again and clock, program settings and recorded data are checked for availability and correctness.

- iii) Instruments with entirely built-in factory replaceable batteries cannot be tested in this way. In such case, the Manufacturer shall provide a technical description of the method applied to avoid loss of clock, program and collected data.

4. Test Execution: Two test programmes are to be executed:

- All Units Test Programme
- Single Unit Test Programme

Prior to execution of the tests, a detailed test script has to be drafted and agreed upon. The test script shall define:

- Test sequence.
- The test conditions and requirements for each test.
- Place of the test.
- Person(s) responsible for conducting the tests.
- Reporting requirements.
- Handling failures and problems.

4.1 All Units Test Programme: The All Units Test Programme aims to identify the malfunctioning instruments and those not compliant with the bid specifications. The Functional Tests, the Clock Accuracy Test and the Zero Stability Test must be executed on each instrument. The design of the tests shall be selective and practical and enable execution with simple means, preferably at the Client's premises.

4.2 Single Unit Test Programme

- i) A full system shall be tested, that is: pressure sensor, electronics, cable, power supply, DRS, software and manuals. The Single Unit Test Programme is a combination of the Functional Tests, the Accuracy Tests and the Overall Test. The Client shall randomly select an instrument for testing from the instruments delivered. The Single Unit Test Programme can only be started after verification that all documents related to the order/delivery, including manuals, calibration data, QA data etc., are delivered to the Client. Any other unit, for which doubts arise on its compliance with the bid specifications, shall also be tested on the client's request.
- ii) Failing to pass the Single Unit Test Programme results in rejection of the entire delivery until the defective units have been repaired to meet the technical specifications, and such to the satisfaction of the Client.

5. Evaluation of test results: The test results have to be evaluated and results and conclusion shall be reported. Instruments that do not meet the bid specifications, shall be replaced by properly functioning and satisfactorily tested instruments.

6. Post acceptance performance monitoring

- i) After installation and field deployment the instrument performance shall be continuously monitored by taking manual observations, initially at a relatively high rate, e.g. every 3 hours, gradually migrating towards the normal monitoring interval. The level comparisons are required for reference and validation purposes. Manual observations and automatic readings shall be taken at short intervals after each other, in practice the time difference shall be kept to less than 15 minutes. The primary criterion though, is that the manual reading shall be taken before the water level changes more than 1 mm.
- ii) Other checks are on functioning of the internal clock, data recording and retrieval, battery discharge, siltation of the sensor, moisture ingress and any development of corrosion.
- iii) The tape used for taking the reference readings shall be of high accuracy, considerably better than the accuracy of the DWLR, only then the performance of the high accuracy instruments can be monitored. However, an accuracy of 1 mm over the full measuring range is enough. Only best quality tapes, e.g. the electric types, come close to this requirement. The tapes shall be checked for accuracy against a precise reference, e.g. over 10 or 20 m on a single stretch. Verification by a standard ruler will not reveal to overall accuracy of a tape. The 'tape verification reference' could be prepared using high accuracy geodetic equipment. A long, straight corridor, or a quiet stretch of road, could accommodate the length reference marks, the accuracy should be 1 mm relative to the reference point (0.000 m).

7. Instrument History File: For each instrument, an individual History File shall be opened and maintained (The Instrument history file shall be suppliers' scope.). In the History File the full instrument history and all documents generated shall be stored. This also includes any changes, adaptations, repairs etc. made to the instruments. The products and results of the execution of the Acceptance Protocol shall be included in the Instrument History File. Some document types and entries are listed below:

7.1 Instrument identification: The instrument identification uniquely defines the instrument particulars.

- Make, vendor, service provider, date of manufacturing, date of delivery
- Instrument make, model and serial number

- Instrument configuration
- Measuring range
- Cable type, length
- Manual version
- Instrument status: e.g. working, under calibration, under repair

7.2 Functional, Accuracy and Over-all tests: For each of the three test categories, a separate and unambiguous record shall be maintained. The test conditions and results shall be duly recorded. Obviously any failures or irregularities shall be annotated accurately and comprehensively, as well as the actions taken and their results. At least the following data shall be recorded:

- Administrative data: what, when, where, who, which instrument and configuration
- List of tests
- Specifications for each test
- Results of each test
- Failures, actions, conclusions

8.0 Acceptance Certificates:

On successful completion of acceptability test, receipt of deliverables etc., and after the purchaser is satisfied with the working of the DWLR system, the acceptance certificate signed by the supplier and the representative of the purchaser will be issued. The date on which such certificate is signed shall be deemed to be the date of successful commissioning of the systems

SECTION-VI

BILL OF QUANTITIES AND SUMMARY OF PACKAGES

SECTION-VI

BILL OF QUANTITIES AND SUMMARY OF PACKAGES

BILL OF QUANTITIES

FINANCIAL TENDER FORMAT PACKAGE-6 HAS BEEN UPLOADED IN THE BOQ SECTION IN THE E-TENDERING SYSTEM WHICH IS AN INTEGRAL PART OF THIS TENDER DOCUMENT.

SUMMARY OF PACKAGE IN RESPECT OF TENDER FOR CONSTRUCTION OF PIEZOMETERS WELLS and SUPPLY AND INSTALLATION OF DWLR AND TELEMETRY

PACKAGE NO	PACKAGE DETAIL	State	BOQ Number	Items	Number of Wells	Number of DWLR		
						With Quality Probe	Without Quality Probe	
6	PART A (PIEZOMETER)	Bihar	BR PZ BOQ 1	SR- (100m)	69	-	-	
			BR PZ BOQ 2	HR/Bouldary- (100m)	06	-	-	
		Jharkhand	JH PZ BOQ 1	HR/Bouldary- (100m)	50	-	-	
			JH PZ BOQ 2	HR/Bouldary- (120m)	35	-	-	
		Uttar Pradesh	UP PZ BOQ 1	SR- (50m)	28	-	-	
			UP PZ BOQ 2	SR- (100m)	389	-	-	
			UP PZ BOQ 3	SR- (150m)	05	-	-	
			UP PZ BOQ 4	SR- (250m)	31	-	-	
			UP PZ BOQ 5	SR- (350m)	14	-	-	
		Odisha	OD PZ BOQ 1	SR- (100m)	15	05	-	
			OD PZ BOQ 2	SR- (300m)	02		-	
			OD PZ BOQ 3	HR- (100m)	17		-	
		West Bengal	WB PZ BOQ 1	SR- (150m)	104	15	-	
			WB PZ BOQ 2	SR- (300m)	27		-	
			WB PZ BOQ 3	SR- (150m)	17		-	
			WB PZ BOQ 4	HR- (150m)	01		-	
		PART B (DWLR)	ALL STATES	DWLR BOQ	DWLR and Telemetry	810	20	790
	TOTAL					810	20	790

NOTE common for BOQ

1. While quoting the rates unit cost should be given for all the items. The items of work in BOQ deemed to be cover all kind of works/ items involved in construction of a well as mention in section V, Scope of Work and

Technical specification, even though if any specific item is not mentioned in the BOQ. Hence no payment will be made for works/ items not mentioned in the BOQ separately.

2. The quantities envisaged in the BOQs are tentative and may vary from site to site the payments will be made on actual basis.
3. No payment will be made for shifting of rig unit and goods required for construction of wells.
4. Unit rates and prices shall be quoted by the bidder in Indian rupee. Amounts must be quoted in full rupees by ignoring fifty paise and considering more than fifty paise as rupee one. Bidders have to quote for all items of works of the BOQ. The item for which no rate or price has been entered in, will not be paid for by the Employer when executed and shall be deemed covered by the other rates and prices in the Bill of Quantities.
5. Any modification of GST by the Government the difference will be paid/ recovered to/from the contractor.
6. The contractors are advised to fill the BOQ in financial bid carefully as the system is digital and it is on line. The rate without GST should be entered against the item in BOQ. The GST at 18% is taken during publishing of this tender document. The payment of GST as applicable will be paid to the contractor on proof of such payment made to the Government.
7. Successful bidder is to comply with the Public Procurement (Preference of Make in India), Order 2017 dated 15.06.2017 as amended upto date, while executing the contract.

BOQ for Bihar State

BR PZ BOQ 1

BOQtemplate for Bihar (Soft Rock 100m) - BH_SR_01					
	State(s)			Bihar	
	Number of piezometer			69	number
	Depth of pilot hole			100	meter
	Average depth of piezometer construction			95	meter
	Diameter of housing pipe			150	mm
	Diameter of intake pipe			150	mm
	Average Length of intake pipe (blank)			77	meter
	Average Length of intake pipe (screen)			18	meter
	Type of screen			LCG	
	Slot opening			1	mm
	Average Development of Pz by air compressor			10	hours
	Collection of water samples per site			2	number
	Natural gamma logging			69	number
	Number of samples per Pz to be tested for Basic Parameters			1	number
	Number of samples per Pz to be tested for Heavy metals			1	number
S. No.	Item of work	Unit	Rate/ unit qty (Excluding GST)	EW Qty	Total Amt. EW (Excluding GST)
1	Drilling of pilot hole using bentonite fluid for Piezometer not larger than 216 mm (8 ½") by rock roller/ drag bit including formation sample collection at every 3m and change in formation , preparation and submission of litholog along with video recordings	meter		7245	
2	Electrical logging using 406 mm and 1626 mm (16" and 64") SP resistivity probe, Natural gamma logging , to target depth of minimum 100m submission of report including zone wise water quality and preparation of composite log along with video recordings	Job		69	

3	Enlargement of hole by reaming in Pz to accommodate well assembly of recommended size and gravel envelop of minimum 100 mm thickness as given below				
3.1	Using 381 mm (15") RR Bit for 150 mm (6") assembly pipe	meter		6762	
6	Supply and installation of ERW casing pipe conforming to latest version of IS: 4270-2001 of diameter and thickness given below				
6.1	150 mm (6") Nominal Bo,re thickness 5.4mm	meter		5348	
7	Supply and installation of LCG V- wire screen conforming to latest version of IS: 8110-2000 of dimensions given below				
7.1	150 mm (6") Nominal Size thicnkness 7mm with slot opening size given below				
7.1.1	Slot opening 1.5 mm	meter		0	
7.1.2	Slot opening 1.0 mm	meter		1242	
7.1.3	Slot opening 0.75 mm	meter		0	
8	Supply and shrouding of pea gravel confirming to latest version of IS: 4097-1967				
8.1	Particle size range 3.35 mm to 4.75 mm for 1.5 mm slot opening	meter		0	
8.2	Particle size range 2.00 mm to 3.35 mm for 1.0 mm and 0.75 mm slot opening	meter		6900	
9	Supply and filling up borehole/ annular space between casing pipe and bore hole wall with local clay, if required	job		69	
10	Development by Air Compressor of adequate capacity for minimum 10 hours, over pumping and by other means till discharge water is clear and free of sand including collection of two water samples adopting standard procedure in 1 litre HDPE bottle, along with video recordings of compressor hour meter, discharge etc.	job		69	
11	chemical analysis of water samples for 15 parameters pH, EC, TH, TDS, Ca, Mg, Na, K, CO3, HCO3, SO4, NO3, Cl, F & Fe in NABL accredited labs	job		69	
12	chemical analysis of water samples for Heavy metals Arsenic, Uranium in NABL accredited labs	job		69	

13	Construction of cement concrete platform of dimension 0.70 X 0.70 X 0.60 m (0.30 m above ground level) using concrete mix of 1:2:4 around the housing pipe welded with minimum 6 Nos of anchoring plate as per drawing	job		69	
14	Supply and fitting of well cap as per drawing with Allen Keys. MS Plate size 5 mm embossed & welded with permanent marking of "CGWB Pz" on wells should be carved with welding on outer surface of casing pipe 0.5mtrs	job		69	
15	Supply and installation of protection box along with Brass lock (7 lever hardened) and three keys for each lock as per drawing	job		69	
16	Supply and installation of Display board as per drawing	job		69	
17	Preparation and submission of basic data report per site in triplicate along with logging graphs, data sheets, analysis sheet, logging graphs, chemical analysis report from NABL lab, site location map and approachability with land marks, photographs and videos of activities of drilling, assembly lowering, gravel measurement and gravel packing, well development using compressor and well water discharge, well site with display board well cap, protection box activity for each site, etc. The soft copy should be submitted. Summary of Pz details in xls format (as per proforma given by CGWB) including details of assembly pipe, screen pipe, static water level, TDS, gravel packing depth and thickness, Litholog etc should be also submitted.	job		69	
Total					
Average rate per well excluding GST					

- Note:**
1. The Pilot hole drilling shall be cross checked with logging depth from logging graph and in case of variation payment to pilot hole drilling shall be limited to logging depth.
 2. No payment shall be made if Pz is abandoned without lowering assembly upto the recommended depth citing formation problem.
 3. No payment shall be made if any Pz is abandoned due to fault of contractor or due to machinery, bore hole fishing, etc citing formation problem except under extraordinary situations like interference/ objection by the Local Government Bodies or public agitation against drilling leading to law and order problems, etc.
 4. Logging should be carried out to target depth of 100m in all Pz

5. Payment for Gravel packing shall be in terms of meterage height measured from the bottom of Reamed depth. Also gravel in terms of volume consumed should be cross checked with theoretical volume of gravel packing to ensure there is no bridging during gravel packing. The actual volume of gravel used and theoretical annular volume gravel should be provided for each Pz.

6. Water samples shall be collected as per the standard procedures at the closure of development as per the standard procedures. Water samples will be collected in 3 pre-treated HDPE containers (1 no. of 1 litre capacity container for Basic parameters, 2nos. of 250ml/500ml capacity containers for heavy metals). The samples for arsenic parameter should be acidified with ultrapure HCl (1:1 HCl) and the samples for other heavy/ trace metals should be acidified with ultrapure HNO₃ (1:1 HNO₃).

7. The water samples collected shall be analysed for basic parameters and heavy metals as per BOQ by the contractor through NABL Lab and one more set of these water samples shall be submitted to CGWB for validation along with original report of NABL Lab.

8. Well development will be treated as completed only when water is clear and free of suspended particles during pumping. Pz will be treated as completed only after construction of Pz as per the recommended well assembly and after conducting the well development, and all other items mentioned in the BOQ including logging, submission of BDRs duly validated by CGWB. Payment for the Pz shall be made only when the Pz is constructed as per the BOQ specification.

BR PZ BOQ 2

BOQ Template for Peizometer in Bihar (Hard Rock 100m) - BH_HR_01					
	State			Bihar	
	Number of Piezometers			6	number
	Depth of Pilot Hole			100	meter
	Average depth of casing			30	meter
	Diameter of MS Pipe for casing			152.4	mm
	Diameter Naked borehole drilling			139.7	mm
	Well completion Depth of Piezometer			100	meter
	Collection of Water Sample per site			2	number
	Number of samples per well to be tested for Basic Paramers			1	number
	Number of samples per well to be tested for Heavy metals			1	number
	Development of Piezometer by air compressor except dry wells			6	number
	Caliper logging			6	number
S. No.	Item of work	Unit	Rate / unit qty for PZ(Rs)	PZ Qty	Total Amount PZ (RS)

1	Drilling of overburden by rock roller/ drag/ button bit to accommodate casing pipe (6" dia.) including sample collection, preparation and submission of litholog	meter		180	
2	Supply and installation of ERW casing pipe conforming to Table 3 of latest version of IS: 4207-2001				
2.1	152.4 mm (6") Nominal Bore	meter		183	
3	Drilling by DTH method using 5 & a half inch (139.7mm) sizes of button bits so as to reach targetted depth with diameter of hole not less than 130mm at hole bottom, measurement of discharge through V-notch at various stages (depth) of drilling, collection of water sample adopting standard procedure, formation sample collection at every 3m intervals, preparation and submission of litholog, discharge measurement, etc.	meter		420	
4	After completion of drilling, development of well (except dry wells) with air compressor for one hour, collection of 2 bottles (1 treated with acid) of water sample (1 lit each)for submission to CGWB, Another one set of sample should be collected by the party for analysis	Job		6	
5	Caliper logging	Job		6	
6	Chemical analysis of water samples (collected during APT/or compressor development /or during drilling)for 15 parameters Ph, EC, TH, TDS, Ca, g, Na, K, CO ₃ , HCO ₃ , SO ₄ , NO ₃ , Cl, F, & Fe, in NABL accredited labs and submission from NABL lab	job		6	
7	Chemical analysis of water samples (collected during APT/or compressor development /or during drilling)for Heavy metals Arsenic, Uranium in NABL accredited labs and submission from NABL lab	job		6	
8	Construction of cement concrete platform 0.70 x 0.70 x 0.60 m (0.30 m above ground level) using concrete mix of 1:2:4 around the housing pipe welded minimum 4 nos. anchoring plate as per drawing	job		6	
9	Fitting of Well cap, cap as per drawing attached	Job		6	
10	Supply and installation of protection box made of GI sheet of 3.15mm thickness along with Brass lock (7 lever hardened) and three keys for each lock as per drawing	job		6	
11	Suppy and installation of display board as per specification drawing	job		6	

12	Preparation and submission of basic data report per site in triplicate copy along with chemical analysis report from NABL lab, caliper log & interpretation, APT data and analysis ,photographs/ videos of activities of drilling, casing lowering, V- notch discharge at various depth of drilling, compressor development, water sample collection, protection box. The soft copy should also be submitted. (BDR should be as per the format of BDR is annexed)	numb er	6		
	Total				
	Average rate per well excluding GST				

**Not
e:**

1. Payment shall be made based on actual executed quantity of each item at site.
 2. The payment of pipe shall be made based on actual consumptions of pipes
 3. The pipes shall be supplied by the bidder as per technical specification
 4. Need based quantity shall be decided as per requirement at site under intimation to CGWB officials at site.
 5. The quoted price should be inclusive of all taxes and duties as applicable,(except GST)
 6. Prior intimation to CGWB is required before start of drilling & related activities
 7. The average overburden thickness is 30 m and overburden thickness may vary upto 45m in few wells.
 8. Two sets of water samples (3nos. of bottles each) are to be collected per well either during drilling/compressor development/APT. One set for submission to CGWB and another set for the party for analysis. Water samples are to be collected at the completion of drilling where there will be no compressor development or APT. Where there will be APT no need to collect samples during drilling or compressor development. Water samples shall be collected as per the standard procedures as per the standard procedures. Water samples will be collected in 3 nos pre-treated HDPE containers . 1 litre capacity container for Basic parameters, 2nos. of 500ml capacity each containers for heavy metals. The samples for arsenic parameter should be acidified with ultrapure HCl (1:1 HCl) and the samples for other heavy/ trace metals should be acidified with ultrapure HNO3 (1:1 HNO3).
- One set of collected water samples shall be submitted to CGWB and water samples should be properly sealed and labeled with the relevant details like location (including Lat and Long), well number , date and time of sampling, details of acidification, water temperature at the time of sample collection, etc.

9. All wells should be constructed to target depth of 100m. The total depth of well shall be crossed checked with logging depth from logging graph. Payment shall be made as per actual depth measured during handing over of well. Abandonment of the well / termination of drilling prior to target depth in case of unfavorable hydrogeological conditions needs approval of CGWB.

10. No payment shall be made if any well is abandoned due to fault of contractor or due to machinery, bore hole fishing, etc citing formation problem except under extraordinary situations like interference/ objection by the Local Government Bodies or public agitation against drilling leading to law and order problems, etc.

11. Prior intimation to CGWB is required before carrying out caliper logging.

12. Monthly Progress should be submitted in a given format

BOQ for Jharkhand State

JH PZ BOQ 1

JH PZ BOQ 1					
	BOQ template for Piezometer in Jharkhand State (Hard Rock 100)				
	State	Jharkhand			
	District	23			
	Number of Piezometers	50			
	Average depth of casing	30			
	Diameter of MS Pipe for casing	152.4mm			
	Naked borehole drilling	139.7mm			
	Well completion Depth of Piezometer	100m			
	Number of samples per well to be tested for Basic Paramers	Need based			
	Number of samples per well to be tested for Heavy metals	Need based			
	Development of Piezometer by air compressor except dry wells	Need based			
	APT where discharge is more than 1 lps	Need based			
	Caliper logging	50			
	PACKAGE-Pz				
	BOQ FOR CONSTRUCTION OF PIEZOMETER IN HARD ROCK FORMATION				
S. No.	Item of work	Unit	Rate/ unit qty for Exploratory Wells	Qty	Total Amount
1	Drilling of overburden by rock roller/ drag/ button bit to accommodate casing pipe (6" dia.) including sample collection, preparation and submission of litholog 30m/well	meter		1500	
2	Supply and installation of ERW casing pipe conforming to Table 3 of latest version of IS: 4270-2001	meter		1525	
2.1	152.4 mm (6") Nominal Bore 30.5m/well				
3	Drilling by DTH method using 5 & a half inch (139.7mm) sizes of button bits so as to reach targetted depth with diameter of hole not less than 127mm at hole bottom, measurement of discharge through V-notch at various stages (depth) of drilling, collection of water sample adopting standard procedure, formation sample collection at every 3m intervals, preparation and submission of litholog, discharge measurement, etc.	meter		3500	

4	After completion of drilling, development of well (except dry wells) with air compressor for one hour, collection of 2 bottles (1 treated with acid) of water sample (1 lit each) for submission to CGWB, Another one set of sample should be collected by the party for analysis	Job		50	
5	Caliper logging	Job		50	
7	Chemical analysis of water samples (collected during APT/or compressor development /or during drilling)for 15 parameters Ph, EC, TH, TDS, Ca, g, Na, K, CO ₃ , HCO ₃ , SO ₄ , NO ₃ , Cl, F, & Fe, in NABL accredited labs and submission from NABL lab	job		50	
8	Chemical analysis of water samples (collected during APT/or compressor development /or during drilling)for Heavy metals Arsenic, Cadmium, Mercury, Lead in NABL accredited labs and submission from NABL lab	job		50	
9	Construction of cement concrete platform 0.70 x 0.70 x 0.60 m (0.30 m above ground level) using concrete mix of 1:2:4 around the housing pipe welded minimum 4 nos. anchoring plate as per drawing	job		50	
10	Fitting of Well cap, cap as per drawing attached	Job		50	
11	Supply and installation of protection box made of GI sheet of 3.15mm thickness along with Brass lock (7 lever hardened) and three keys for each lock as per drawing	job		50	
12	Supply and installation of display board as per specification drawing	job		50	
13	Preparation and submission of basic data report per site in triplicate along with chemical analysis report from NABL lab, caliper log & interpretation, APT data and analysis, photographs/ videos of activities of drilling, casing lowering, V- notch discharge at various depth of drilling, compressor development, water sample collection, protection box. The soft copy should be submitted. (BDR should be as per the format of BDR is annexed)	number		50	
Grand Total (exclusive of GST)					
Terms and conditions					
1	Payment shall be made based on actual executed quantity of each item at site.				
2	The payment of pipe shall be made based on actual consumptions of pipes				
3	The pipes shall be supplied by the bidder as per technical specification				
4	Need based quantity shall be decided as per requirement at site under intimation to CGWB officials at site.				
5	The quoted price should be inclusive of all taxes and duties as applicable,(except GST)				
6	Prior intimation to CGWB is required before start of drilling & related activities				

7	The average overburden thickness is 30 m and overburden thickness may vary upto 45m in few wells.
8	Two sets of water samples (3nos. of bottles each) are to be collected per well either during drilling/compressor development. One set for submission to CGWB and another set for the party for analysis. Water samples are to be collected at the completion of drilling where there will be no compressor development.
9	All wells should be constructed to target depth of 100m. The total depth of well shall be crossed checked with logging depth from logging graph. Payment shall be made as per actual depth measured during handing over of well. Abandonment of the well / termination of drilling prior to target depth in case of unfavorable hydrogeological conditions needs approval of CGWB.
10	No payment shall be made if any well is abandoned due to fault of contractor or due to machinery, bore hole fishing, etc citing formation problem except under extraordinary situations like interference/ objection by the Local Government Bodies or public agitation against drilling leading to law and order problems, etc.
11	Prior intimation to CGWB is required before carrying out caliper logging.
12	Monthly Progress should be submitted in a given format

JH PZ BOQ 2					
BOQ template for Piezometer in Jharkhand State (Hard Rock 120m)					
	State	Jharkhand			
	District	23			
	Number of Piezometers	35			
	Average depth of casing	30			
	Diameter of MS Pipe for casing	152.4mm			
	Naked borehole drilling	139.7mm			
	Well completion Depth of Piezometer	120m			
	Number of samples per well to be tested for Basic Paramers	Need based			
	Number of samples per well to be tested for Heavy metals	Need based			
	Development of Piezometer by air compressor except dry wells	Need based			
	APT where discharge is more than 1 lps	Need based			
	Caliper logging	35			
	PACKAGE-Pz				
	BOQ FOR CONSTRUCTION OF PIEZOMETER IN HARD ROCK FORMATION				
S. No	Item of work	Unit	Rate/ unit qty for Exploratory Wells	Qty	Total Amount
1	Drilling of overburden by rock roller/ drag/ button bit to accommodate casing pipe (6" dia.) including sample collection, preparation and submission of litholog	meter		1050	

2	Supply and installation of ERW casing pipe conforming to Table 3 of latest version of IS: 4270-2001	meter		1067.5	
2.1	152.4 mm (6") Nominal Bore 30.50m/well				
3	Drilling by DTH method using 5 & a half inch (139.7mm) sizes of button bits so as to reach targetted depth with diameter of hole not less than 127mm at hole bottom, measurement of discharge through V-notch at various stages (depth) of drilling, collection of water sample adopting standard procedure, formation sample collection at every 3m intervals, preperation and submission of litholog, discharge measurement, etc.	meter		3150	
4	After completion of drilling, development of well (except dry wells) with air compressor for one hour, collection of 2 bottles (1 treated with acid) of water sample (1 lit each)for submission to CGWB, Another one set of sample should be collected by the party for analysis	Job		35	
5	Caliper logging	Job		35	
7	Chemical analysis of water samples (collected during APT/or compressor development /or during drilling)for 15 parameters Ph, EC, TH, TDS, Ca, g, Na, K, CO3, HCO3, SO4, NO3, Cl, F, & Fe, in NABL accredited labs and submission from NABL lab	job		35	
8	Chemical analysis of water samples (collected during APT/or compressor development /or during drilling)for Heavy metals Arsenic & Uranium in NABL accredited labs and submission from NABL lab	job		35	
9	Construction of cement concrete platform 0.70 x 0.70 x 0.60 m (0.30 m above ground level) using concrete mix of 1:2:4 around the housing pipe welded mnimu 4 nos. anchoring plate as per drawing	job		35	
10	Fitting of Well cap, cap as per drawing attached	Job		35	
11	Supply and installation of protection box made of GI sheet of 3.15mm thickness along with Brass lock (7 lever hardened) and three keys for each lock as per drawing	job		35	
12	Suppy and installation of display board as per specification drawing	job		35	

13	Preparation and submission of basic data report per site in triplicate along with chemical analysis report from NABL lab, caliper log & interpretation, APT data and analysis, photographs/ videos of activities of drilling, casing lowering, V- notch discharge at various depth of drilling, compressor development, water sample collection, protection box. The soft copy should be submitted. (BDR should be as per the format of BDR is annexed)	number		35	
Grand Total (exclusive of GST)					
Terms and conditions					
1	Payment shall be made based on actual executed quantity of each item at site.				
2	The payment of pipe shall be made based on actual consumptions of pipes				
3	The pipes shall be supplied by the bidder as per technical specification				
4	Need based quantity shall be decided as per requirement at site under intimation to CGWB officials at site.				
5	The quoted price should be inclusive of all taxes and duties as applicable,(except GST)				
6	Prior intimation to CGWB is required before start of drilling & related activities				
7	The average overburden thickness is 30 m and overburden thickness may vary upto 45m in few wells.				
8	Two sets of water samples (3nos. of bottles each) are to be collected per well either during drilling/compressor development. One set for submission to CGWB and another set for the party for analysis. Water samples are to be collected at the completion of drilling where there will be no compressor development.				
9	All wells should be constructed to target depth of 120m. The total depth of well shall be crossed checked with logging depth from logging graph. Payment shall be made as per actual depth measured during handing over of well. Abandonment of the well / termination of drilling prior to target depth in case of unfavorable hydrogeological conditions needs approval of CGWB.				
10	No payment shall be made if any well is abandoned due to fault of contractor or due to machinery, bore hole fishing, etc citing formation problem except under extraordinary situations like interference/ objection by the Local Government Bodies or public agitation against drilling leading to law and order problems, etc.				
11	Prior intimation to CGWB is required before carrying out caliper logging.				
12	Monthly Progress should be submitted in a given format				

BOQ for Uttar Pradesh State

UP PZ BOQ 1

BOQ template for Uttar Pradesh (Soft Rock 50m)/ UP_NR_Pz_01			
Piezometers			
A	State		Uttar Pradesh
B	District		8 Districts
C	Number of Piezometers		28
E	Depth of Pilot Hole Piezometers		55 m

G	Average depth of casing		50 m
H	Diameter of pipe for casing		4 inch
I	Well Completion Depth of PZ		50 m
J	Diameter of intake pipe		100 mm
K	Length of intake pipe (blank)		35 m
L	Length of intake pipe (screen)		15 m
M	Type of screen	LCG	
N	Slot opening		0.75/1.00 mm
O	Development of Piezometer by air compressor		5 Hours/ Pz
P	Number of samples per well to be tested for Basic Parameters	Number	1
Q	Number of samples per well to be tested for Heavy metals	Number	1

BOQ FOR CONSTRUCTION OF PIEZOMETERS (50m) IN SOFT ROCK FORMATION IN UTTAR PRADESH

Sr. No.	Item of Work	Piezometers			
		Qty	Units	Unit Cost	Total Cost
1	Drilling of pilot hole for PZ not larger than 216mm (8 1/2 " by rock roller/ drag bit including sample collection and preparation of litholog	1540	Meter		
2	Electrical Logging using 406mm and 1626mm (16" and 64"), SP resistivity probe and Natural Gamma logging, preparation of litholog, submission of report including zone wise water quality along with logging graphs, composite log etc.	28	Job		
3	Enlargement of hole by reaming in PZ to accommodate well assembly of recommended size and gravel envelope of minimum 100 mm thickness as given below				
3.1	Using 250 mm (10") RR Bit for 100 mm(4") assembly pipe (for 100m depth Pzs)	1540	Meter		
3.2	Using 317.5 mm (12-1/2") RR Bit for 150 mm(6") assembly pipe (For 250-350 m depth Pzs)	0	Meter		
4	Supply and Installation of ERW casing pipe conforming to Table 3 of latest version of IS: 4270-2001 of diameter and thickness given below	0			
4.1	100mm (4") Nominal Bore thickness 5.4mm	1120	Meter		

4.2	150mm (6") Nominal Bore thickness 5.4mm	0	Meter		
6	Supply and installation of LCG V- wire screen conforming to latest version of IS: 8110-2000 of dimension given below				
6.1	100mm (4") Normal Size thickness 7mm with slot opening size given below				
6.1.1	Slot opening 0.75 mm	0	meter		
6.1.2.	Slot opening 1.0 mm	280	meter		
6.2	150mm (6") Normal Size thickness 7mm with slot opening size given below				
6.2.1.	Slot opening 0.75 mm	0	meter		
6.2.1.	Slot opening 1.0 mm	0	meter		
7	Supply and shrouding 01 pea gravel confirming to Latest version of IS: 4097-1967				
7.1	Particle size range 2.00 mm to 4.5 mm for 1.0 mm and 0.75 mm slot opening	67	CUM		
8	Supply and filling up borehole/ annular space between casing pipe and bore hole wall with local clay, if required	0	Job		
9	Collection of Water Samples during compressor development and analysis of the sample				
9.1.	Chemical analysis of water samples for 15 parameters pH, EC, TH, TDS, Ca, Mg, Na, K, CO ₃ , HCO ₃ , SO ₄ , NO ₃ , Cl, F & Fe in NABL accredited labs	28	Job		
9.2.	Chemical analysis of water samples for Heavy metals (As, Pb, Zn, Cu, Cr, Se, Ni, Mn, U) in NABL accredited labs and submission of report from NABL accredited lab	28	Job		
10	Deployments by Air Compressor of adequate capacity for minimum 5 hours till discharge water is clear and free of sand including collection of water samples from PZ. Collection of Water samples asper prescribed format mentioned below.	28	Job		
11	Supply and fitting of well cap asper drawing with allen keys. MS plate size 5mm embossed and welded with permanent marking by welded method as "CGWB_Pz_Depth".				
11.1.	For 4" dia Piezometers	28	Job		

11.2	For 6" dia Piezometers	0	Job		
12	Construction of Cement concrete platform 0.7*0.7*0.6 m (0.3 m above ground level) using concrete mix of 1:2:4 around the piezometer well welded minimum 6 ns of anchoring plate as per drawing	28	Job		
13	Supply and installation of display board as per drawing	28	Job		
14	Supply and installation of protection box along with brass lock (7lever hardened) and three keys for each lock as per drawing	28	Job		
15	Preparation and submission of basic data report per site in triplicate along with logging graphs, data sheets, analysis sheet, logging graphs, chemical analysis report from NABL lab, site location map and approachability with land marks, photographs and videos of activities of drilling, assembly lowering, gravel measurement and gravel packing, well development using compressor and well water discharge, water sample collection during compressor development, well discharge with discharge measurement via V-Notch, well site with display board well cap, protection box activity for each Pz site, etc. The soft copy should be submitted. Summary of wells details in xls format (as per proforma given by CGWB) including details of dia and depth housing pipe, assembly pipe, screen pipe, static water level, TDS, aquifer parameters, safe discharge, gravel packing depth and thickness, Litholog etc should be also submitted.	28	Job		
	Construction Cost (A)				
	GST @ 18%				
	Grand Total (A+B)				
	Average construction cost per Pz with GST				
Notes					
1. The Pilot hole drilling should be carried out to target depth of 50m plus 5m or to the depth of bed rock whichever is early and shall be cross checked with logging depth from logging graph and in case of variation payment to pilot hole drilling shall be limited to logging depth.					
2. Reaming depth for should be total Pz depth plus 5m					
3. Total Reaming depth in a well shall not exceed total assembly depth plus 5m and payment shall be made as actual reaming depth or assembly depth plus 5m which ever is less.					
4. No payment shall be made if well is abandoned without lowering assembly upto the recommended depth citing formation problem.					
5. No payment shall be made if any well is abandoned due to fault of contractor or due to machinery, bore hole fishing, etc citing formation problem except under extraordinary situations like interference/ objection by the Local Government Bodies or public agitation against drilling leading to law and order problems, etc.					

6. Logging should be carried out to target depth of 50m in all Pzs or to the depth of bedrock whichever is lower in all Pzs.
7. Payment for Gravel packing shall be in terms of meterage height measured from the bottom of Reamed depth. Also gravel in terms of volume consumed should be cross checked with theoretical volume of gravel packing to ensure there is no bridging during gravel packing. The actual volume of gravel used and theoretical annular volume gravel should be provided for each wells
*8. Water samples shall be collected as per the standard procedures at the closure of well development (in Pz) as per the standard procedures. Water samples will be collected in 3 pre-treated HDPE containers (1 no. of 1 litre capacity container for Basic parameters, 2nos. of 250ml/500ml capacity containers for heavy metals). The samples for arsenic parameter and Uranium should be acidified with ultrapure HCl (1:1 HCl) and the samples for other heavy/ trace metals should be acidified with ultrapure HNO3 (1:1 HNO3).
*9 All the collected water samples shall be submitted to CGWB and water samples should be properly sealed and labelled with the relevant details like location (including Lat and Long), well number and type, date and time of sampling, stage of pumping test/ well development, details of acidification, water temperature at the time of sample collection, etc.
10.Immediately afer lowering of assembly, gravel packing should be carried out immediately and and withing two days of lowering of assembly and gravel packing, using compressor, well should be developed , followed by other means of well development. Well development will be treated as completed only when water is clear and free of suspended particles . Well will be treated as completed only after construction of well as per the recommended well assembly and after conducting the well development, pumping test and all other items mentioned in the BOQ including logging, submission of BDRs duly validated by CGWB . Payment for the well shall be made only when the well is constructed as per the BOQ specification.
12. Summary of wellwise data i.e site location with latitude-longitude, pilot hole depth, pilot hole dia, logging depth as per graph, assembly dia and depth, gravel packing depth range, water quality parameter (to be analysed by CGWB), static water level, discharge, Transmissivity etc in xls as per proforma given by CGWB should be submitted on completion of all wells
13. Lithosamples collected at 3m interval (minimum 250 g/ 3m) as per BOQ should be properly packed in good quality plastic transparent bottles and should be tagged with details of sample No, site name, well type, depth range of litholog, etc and should be submitted to CGWB Regional office along with drill time log and logging details including logging graph.

UP PZ BOQ 2

BOQ template for Uttar Pradesh (Soft Rock 100m)/ UP_NR_Pz_02			
PIEZOMETERS			
A	State		Uttar Pradesh
B	District		49 Districts
C	Number of Piezometers		389
E	Depth of Pilot Hole Piezometers		105 m
G	Average depth of casing		80 m
H	Diameter of pipe for casing		4 inch
I	Well Completion Depth of PZ		80 m

J	Diameter of intake pipe		100 mm
K	Length of intake pipe (blank)		65 m
L	Length of intake pipe (screen)		15 m
M	Type of screen	LCG	
N	Slot opening		0.75/1.00 mm
O	Development of Piezometer by air compressor		5 Hours/Pz
P	Number of samples per well to be tested for Basic Parameters	Number	1
Q	Number of samples per well to be tested for Heavy metals	Number	1

BOQ FOR CONSTRUCTION OF PIEZOMETERS (100m) IN SOFT ROCK FORMATION IN UTTAR PRADESH

Sr. No.	Item of Work	Piezometers			
		Qty	Units	Unit Cost	Total Cost
1	Drilling of pilot hole for PZ not larger than 216mm (8 1/2 " by rock roller/ drag bit including sample collection and preparation of litholog	40845	Meter		
2	Electrical Logging using 406mm and 1626mm (16" and 64"), SP resistivity probe and Natural Gamma logging, preparation of litholog, submission of report including zone wise water quality along with logging graphs, composite log etc.	389	Job		
3	Enlargement of hole by reaming in PZ to accommodate well assembly of recommended size and gravel envelope of minimum 100 mm thickness as given below				
3.1	Using 250 mm (10") RR Bit for 100 mm(4") assembly pipe (for 100m depth Pzs)	33065	Meter		
3.2	Using 317.5 mm (12-1/2") RR Bit for 150 mm(6") assembly pipe (For 250-350 m depth Pzs)	0	Meter		
4	Supply and Installation of ERW casing pipe conforming to Table 3 of latest version of IS: 4270-2001 of diameter and thickness given below				

4.1	100mm (4") Nominal Bore thickness 5.4mm	25285	Meter		
4.2	150mm (6") Nominal Bore thickness 5.4mm	0	Meter		
6	Supply and installation of LCG V- wire screen conforming to latest version of IS: 8110-2000 of dimension given below				
6.1	100mm (4") Normal Size thickness 7mm with slot opening size given below				
6.1.1	Slot opening 0.75 mm	3501	meter		
6.1.2.	Slot opening 1.0 mm	2334	meter		
6.2	150mm (6") Normal Size thickness 7mm with slot opening size given below				
6.2.1.	Slot opening 0.75 mm	0	meter		
6.2.1.	Slot opening 1.0 mm	0	meter		
7	Supply and shrouding 01 pea gravel confirming to Latest version of IS: 4097-1967				
7.1	Particle size range 2.00 mm to 4.5 mm for 1.0 mm and 0.75 mm slot opening	1422	CUM		
8	Supply and filling up borehole/ annular space between casing pipe and bore hole wall with local clay, if required	0	Job		
9	Collection of Water Samples during compressor development and analysis of the sample				
9.1.	Chemical analysis of water samples for 15 parameters pH, EC, TH, TDS, Ca, Mg, Na, K, CO ₃ , HCO ₃ , SO ₄ , NO ₃ , Cl, F & Fe in NABL accredited labs	389	Job		
9.2.	Chemical analysis of water samples for Heavy metals (As, Pb, Zn, Cu, Cr, Se, Ni, Mn, U) in NABL accredited labs and submission of report from NABL accredited lab	389	Job		
10	Deployments by Air Compressor of adequate capacity for minimum 5 hours till discharge water is clear and free of sand including collection of water samples from PZ. Collection of Water samples asper prescribed format mentioned below.	389	Job		

11	Supply and fitting of well cap as per drawing with allen keys. MS plate size 5mm embossed and welded with permanent marking by welded method as "CGWB_Pz_Depth".				
11.1.	For 4" dia Piezometers	389	Job		
11.2	For 6" dia Piezometers	0	Job		
12	Construction of Cement concrete platform 0.7*0.7*0.6 m (0.3 m above ground level) using concrete mix of 1:2:4 around the pipe welded minimum 6 ns of anchoring plate as per drawing	389	Job		
13	Supply and installation of display board as per drawing	389	Job		
14	Supply and installation of protection box along with brass lock (7lever hardened) and three keys for each lock as per drawing	389	Job		
15	Preparation and submission of basic data report per site in triplicate along with logging graphs, data sheets, analysis sheet, logging graphs, chemical analysis report from NABL lab, site location map and approachability with land marks, photographs and videos of activities of drilling, assembly lowering, gravel measurement and gravel packing, well development using compressor and well water discharge, water sample collection during compressor development, well discharge with discharge measurement via V-Notch, well site with display board well cap, protection box activity for each Pz site, etc. The soft copy should be submitted. Summary of wells details in xls format (as per proforma given by CGWB) including details of dia and depth housing pipe, assembly pipe, screen pipe, static water level, TDS, aquifer parameters, safe discharge, gravel packing depth and thickness, Litholog etc should be also submitted.	389	Job		
	Construction Cost (A) in Rupees				
	GST @ 18%				
	Enlargement of hole by reaming in PZ to accommodate well assembly of recommended size and gravel envelope of minimum 100 mm thickness as given below+				

Notes					
<p>1. The Pilot hole drilling should be carried out to target depth of 100m plus 5m or to the depth of bed rock whichever is early and shall be crossed checked with logging depth from logging graph and in case of variation payment to pilot hole drilling shall be limited to logging depth.</p>					
<p>2. Reaming depth for should be total Pz depth plus 5m</p>					
<p>3. Total Reaming depth in a well shall not exceed total assembly depth plus 5m and payment shall be made as actual reaming depth or assembly depth plus 5m which ever is less.</p>					
<p>4. No payment shall be made if well is abandoned without lowering assembly upto the recommended depth citing formation problem.</p>					
<p>5. No payment shall be made if any well is abandoned due to fault of contractor or due to machinery, bore hole fishing, etc citing formation problem except under extraordinary situations like interference/ objection by the Local Government Bodies or public agitation against drilling leading to law and order problems, etc.</p>					
<p>6. Logging should be carried out to target depth of 100m or to the depth of bedrock whichever is lower in all Pzs.</p>					
<p>7. Payment for Gravel packing shall be in terms of meterage height measured from the bottom of Reamed depth. Also gravel in terms of volume consumed should be cross checked with theoretical volume of gravel packing to ensure there is no bridging during gravel packing. The actual volume of gravel used and theoretical annular volume gravel should be provided for each wells</p>					
<p>*8. Water samples shall be collected as per the standard procedures at the closure of well development (in Pz) as per the standard procedures. Water samples will be collected in 3 pre-treated HDPE containers (1 no. of 1 litre capacity container for Basic parameters, 2nos. of 250ml/500ml capacity containers for heavy metals). The samples for arsenic parameter and Uranium should be acidified with ultrapure HCl (1:1 HCl) and the samples for other heavy/ trace metals should be acidified with ultrapure HNO3 (1:1 HNO3).</p>					
<p>*9 All the collected water samples shall be submitted to CGWB and water samples should be properly sealed and labelled with the relevant details like location (including Lat and Long), well number and type, date and time of sampling, stage of pumping test/ well development, details of acidification, water temperature at the time of sample collection, etc.</p>					
<p>10.Immediately afer lowering of assembly, gravel packing should be carried out immediatly and and withing two days of lowering of assembly and gravel packing, using compressor, well should be developed , followed by other means of well development. Well development will be treated as completed only when water is clear and free of suspended particles . Well will be treated as completed only after construction of well as per the recommended well assembly and after conducting the well development, pumping test and all other items mentioned in the BOQ including logging, submission of BDRs duly validated by CGWB . Payment for the well shall be made only when the well is constructed as per the BOQ specification.</p>					

12. Summary of wellwise data i.e site location with latitude-longitude, pilot hole depth, pilot hole dia, logging depth as per graph, assembly dia and depth, gravel packing depth range, water quality parameter (to be analysed by CGWB), static water level, discharge, Transmissivity etc in xls as per proforma given by CGWB should be submitted on completion of all wells

13. Lithosamples collected at 3m interval (minimum 250 g per 3meter interval) as per BOQ should be properly packed in good quality plastic transparent bottles and should be tagged with details of sample No, site name, well type, depth range of litholog, etc and should be submitted to CGWB Regional office along with drill time log and logging details including logging graph.

UP PZ BOQ 3

BOQ template for Uttar Pradesh (Soft Rock 150m)/ UP_NR_Pz_03			
PIEZOMETERS			
A	State		Uttar Pradesh
B	District		1 Districts
C	Number of Piezometers		5
E	Depth of Pilot Hole Piezometers		155 m
G	Average depth of casing		130 m
H	Diameter of pipe for casing		6 inch
I	Well Completion Depth of PZ		130 m
J	Diameter of intake pipe		150 mm
K	Length of intake pipe (blank)		115 m
L	Length of intake pipe (screen)		15 m
M	Type of screen	LCG	
N	Slot opening		0.75/1.00 mm
O	Development of Piezometer by air compressor		5 Hours/ Pz
P	Number of samples per well to be tested for Basic Parameters	number	1
Q	Number of samples per well to be tested for Heavy metals	number	1

BOQ FOR CONSTRUCTION OF PIEZOMETERS (150m) IN SOFT ROCK FORMATION IN UTTAR PRADESH

Sr. No.	Item of Work	Piezometers
----------------	---------------------	--------------------

		Qty	Units	Unit Cost in Rs	Total Cost in Rs
1	Drilling of pilot hole for PZ not larger than 216mm (8 1/2 " by rock roller/ drag bit including sample collection and preparation of litholog	755	Meter		
2	Electrical Logging using 406mm and 1626mm (16" and 64"), SP resistivity probe and Natural Gamma logging, preparation of litholog, submission of report including zone wise water quality along with logging graphs, composite log etc.	5	Job		
3	Enlargement of hole by reaming in PZ to accommodate well assembly of recommended size and gravel envelope of minimum 100 mm thickness as given below				
3.1	Using 250 mm (10') RR Bit for 100 mm(4") assembly pipe (for 100m depth Pzs)	0	Meter		
3.2	Using 317.5 mm (12-1/2") RR Bit for 150 mm(6") assembly pipe (For 250-350 m depth Pzs)	725	Meter		
4	Supply and Installation of ERW casing pipe conforming to Table 3 of latest version of IS: 4270-2001 of diameter and thickness given below				
4.1	100mm (4") Nominal Bore thickness 5.4mm	0	Meter		
4.2	150mm (6") Nominal Bore thickness 5.4mm	625	Meter		
6	Supply and installation of LCG V- wire screen conforming to latest version of IS: 8110-2000 of dimension given below				
6.1	100mm (4") Normal Size thickness 7mm with slot opening size given below				
6.1.1	Slot opening 0.75 mm	0	meter		
6.1.2.	Slot opening 1.0 mm	0	meter		
6.2	150mm (6") Normal Size thickness 7mm with slot opening size given below				
6.2.1.	Slot opening 0.75 mm	45	meter		
6.2.1.	Slot opening 1.0 mm	30	meter		

7	Supply and shrouding 01 pea gravel confirming to Latest version of IS: 4097-1967				
7.1	Particle size range 2.00 mm to 4.5 mm for 1.0 mm and 0.75 mm slot opening	40	CUM		
8	Supply and filling up borehole/ annular space between casing pipe and bore hole wall with local clay, if required	0	Job		
9	Collection of Water Samples during compressor development and analysis of the sample				
9.1.	Chemical analysis of water samples for 15 parameters pH, EC, TH, TDS, Ca, Mg, Na, K, CO ₃ , HCO ₃ , SO ₄ , NO ₃ , Cl, F & Fe in NABL accredited labs	5	Job		
9.2.	Chemical analysis of water samples for Heavy metals (As, Pb, Zn, Cu, Cr, Se, Ni, Mn, U) in NABL accredited labs and submission of report from NABL accredited lab	5	Job		
10	Deployments by Air Compressor of adequate capacity for minimum 5 hours till discharge water is clear and free of sand including collection of water samples from PZ. Collection of Water samples asper prescribed format mentioned below.	5	Job		
11	Supply and fitting of well cap asper drawing with allen keys. MS plate size 5mm embossed and welded with permanent marking by welded method as "CGWB_Pz_Depth".				
11.1.	For 4" dia Piezometers	0	Job		
11.2	For 6" dia Piezometers	5	Job		
12	Construction of Cement concrete platform 0.7*0.7*0.6 m (0.3 m above ground level) using concrete mix of 1:2:4 around the pipe welded minimum 6 ns of anchoring plate asper drawing	5	Job		
13	Supply and installation of display board asper drawing	5	Job		
14	Supply and installation of protection box along with brass lock (7lever hardened) and three keys for each lock asper drawing	5	Job		

15	Preparation and submission of basic data report per site in triplicate along with logging graphs, data sheets, analysis sheet, logging graphs, chemical analysis report from NABL lab, site location map and approachability with land marks, photographs and videos of activities of drilling, assembly lowering, gravel measurement and gravel packing, well development using compressor and well water discharge, water sample collection during compressor development, well discharge with discharge measurement via V-Notch, well site with display board well cap, protection box activity for each Pz site, etc. The soft copy should be submitted. Summary of wells details in xls format (as per proforma given by CGWB) including details of dia and depth housing pipe, assembly pipe, screen pipe, static water level, TDS, aquifer parameters, safe discharge, gravel packing depth and thickness, Litholog etc should be also submitted.	5	Job		
	Construction Cost (A) in Rs				
	GST @ 18%				
	Grand Total (A+B) in Rs				
Notes					
1. The Pilot hole drilling should be carried out to target depth of 150m plus 5m or to the depth of bed rock whichever is early and shall be cross checked with logging depth from logging graph and in case of variation payment to pilot hole drilling shall be limited to logging depth.					
2. Reaming depth for should be total Pz depth plus 5m					
3. Total Reaming depth in a well shall not exceed total assembly depth plus 5m and payment shall be made as actual reaming depth or assembly depth plus 5m which ever is less.					
4. No payment shall be made if well is abandoned without lowering assembly upto the recommended depth citing formation problem.					
5. No payment shall be made if any well is abandoned due to fault of contractor or due to machinery, bore hole fishing, etc citing formation problem except under extraordinary situations like interference/ objection by the Local Government Bodies or public agitation against drilling leading to law and order problems, etc.					
6. Logging should be carried out to target depth of 100m or to the depth of bedrock whichever is lower in all Pzs.					
7. Payment for Gravel packing shall be in terms of meterage height measured from the bottom of Reamed depth. Also gravel in terms of volume consumed should be cross checked with theoretical volume of gravel packing to ensure there is no bridging during gravel packing. The actual volume of gravel used and theoretical annular volume gravel should be provided for each wells					

<p>*8. Water samples shall be collected as per the standard procedures at the closure of well development (in Pz) as per the standard procedures. Water samples will be collected in 3 pre-treated HDPE containers (1 no. of 1 litre capacity container for Basic parameters, 2nos. of 250ml/500ml capacity containers for heavy metals). The samples for arsenic parameter and Uranium should be acidified with ultrapure HCl (1:1 HCl) and the samples for other heavy/ trace metals should be acidified with ultrapure HNO₃ (1:1 HNO₃).</p>
<p>*9 All the collected water samples shall be submitted to CGWB and water samples should be properly sealed and labelled with the relevant details like location (including Lat and Long), well number and type, date and time of sampling, stage of pumping test/ well development, details of acidification, water temperature at the time of sample collection, etc.</p>
<p>10.Immediately afer lowering of assembly, gravel packing should be carried out immediately and and withing two days of lowering of assembly and gravel packing, using compressor, well should be developed , followed by other means of well development. Well development will be treated as completed only when water is clear and free of suspended particles . Well will be treated as completed only after construction of well as per the recommended well assembly and after conducting the well development, pumping test and all other items mentioned in the BOQ including logging, submission of BDRs duly validated by CGWB . Payment for the well shall be made only when the well is constructed as per the BOQ specification.</p>
<p>12. Summary of wellwise data i.e site location with latitude-longitude, pilot hole depth, pilot hole dia, logging depth as per graph, assembly dia and depth, gravel packing depth range, water quality parameter (to be analysed by CGWB), static water level, discharge, Transmissivity etc in xls as per proforma given by CGWB should be submitted on completion of all wells</p>
<p>13. Lithosamples collected at 3m interval (minimum 250 g per 3meter interval) as per BOQ should be properly packed in good quality plastic transparent bottles and should be tagged with details of sample No, site name, well type, depth range of litholog, etc and should be submitted to CGWB Regional office along with drill time log and logging details including logging graph.</p>

UP PZ BOQ 4

BOQ template for Uttar Pradesh (Soft Rock 250m)/ UP_NR_Pz_04			
PIEZOMETERS			
A	State		Uttar Pradesh
B	District		9 Districts
C	Number of Piezometers		31
E	Depth of Pilot Hole Piezometers		255 m
G	Average depth of casing		230 m

H	Diameter of pipe for casing		6 inch
I	Well Completion Depth of PZ		230 m
J	Diameter of intake pipe		150 mm
K	Length of intake pipe (blank)		215 m
L	Length of intake pipe (screen)		15 m
M	Type of screen	LCG	
N	Slot opening		0.75/1.00 mm
O	Development of Piezometer by air compressor		5 Hours/ Pz
P	Number of samples per well to be tested for Basic Parameters	Number	1
Q	Number of samples per well to be tested for Heavy metals	Number	1

BOQ FOR CONSTRUCTION OF PIEZOMETERS (250m) IN SOFT ROCK FORMATION IN UTTAR PRADESH

Sr. No.	Item of Work	Piezometers			
		Qty	Units	Unit Cost in Rs	Total Cost in Rs
1	Drilling of pilot hole for PZ not larger than 216mm (8 1/2 " by rock roller/ drag bit including sample collection and preparation of litholog	7905	Meter		
2	Electrical Logging using 406mm and 1626mm (16" and 64"), SP resistivity probe and Natural Gamma logging, preparation of litholog, submission of report including zone wise water quality along with logging graphs, composite log etc.	31	Job		
3	Enlargement of hole by reaming in PZ to accommodate well assembly of recommended size and gravel envelope of minimum 100 mm thickness as given below				
3.1	Using 250 mm (10') RR Bit for 100 mm(4") assembly pipe (for 100m depth Pzs)	0	Meter		
3.2	Using 317.5 mm (12-1/2") RR Bit for 150 mm(6") assembly pipe (For 250-350 m depth Pzs)	7285	Meter		

4	Supply and Installation of ERW casing pipe conforming to Table 3 of latest version of IS: 4270-2001 of diameter and thickness given below				
4.1	100mm (4") Nominal Bore thickness 5.4mm	0	Meter		
4.2	150mm (6") Nominal Bore thickness 5.4mm	6665	Meter		
6	Supply and installation of LCG V-wire screen conforming to latest version of IS: 8110-2000 of dimension given below				
6.1	100mm (4") Normal Size thickness 7mm with slot opening size given below				
6.1.1	Slot opening 0.75 mm	0	meter		
6.1.2.	Slot opening 1.0 mm	0	meter		
6.2	150mm (6") Normal Size thickness 7mm with slot opening size given below				
6.2.1.	Slot opening 0.75 mm	279	meter		
6.2.1.	Slot opening 1.0 mm	186	meter		
7	Supply and shrouding 01 pea gravel confirming to Latest version of IS: 4097-1967	0			
7.1	Particle size range 2.00 mm to 4.5 mm for 1.0 mm and 0.75 mm slot opening	406	CUM		
8	Supply and filling up borehole/ annular space between casing pipe and bore hole wall with local clay, if required	0	Job		
9	Collection of Water Samples during compressor development and analysis of the sample				
9.1.	Chemical analysis of water samples for 15 parameters pH, EC, TH, TDS, Ca, Mg, Na, K, CO ₃ , HCO ₃ , SO ₄ , NO ₃ , Cl, F & Fe in NABL accredited labs	31	Job		
9.2.	Chemical analysis of water samples for Heavy metals (As, Pb, Zn, Cu, Cr, Se, Ni, Mn, U) in NABL accredited labs and submission of report from NABL accredited lab	31	Job		

10	Deployments by Air Compressor of adequate capacity for minimum 10 hours till discharge water is clear and free of sand including collection of water samples from PZ. Collection of Water samples as per prescribed format mentioned below.	31	Job		
11	Supply and fitting of well cap as per drawing with allen keys. MS plate size 5mm embossed and welded with permanent marking by welded method as "CGWB_Pz_Depth".				
11.1.	For 4" dia Piezometers	0	Job		
11.2	For 6" dia Piezometers	31	Job		
12	Construction of Cement concrete platform 0.7*0.7*0.6 m (0.3 m above ground level) using concrete mix of 1:2:4 around the pipe welded minimum 6 nos of anchoring plate as per drawing	31	Job		
13	Supply and installation of display board as per drawing	31	Job		
14	Supply and installation of protection box along with brass lock (7lever hardened) and three keys for each lock as per drawing	31	Job		

15	Preparation and submission of basic data report per site in triplicate along with logging graphs, data sheets, analysis sheet, logging graphs, chemical analysis report from NABL lab, site location map and approachability with land marks, photographs and videos of activities of drilling, assembly lowering, gravel measurement and gravel packing, well development using compressor and well water discharge, water sample collection during compressor development, well discharge with discharge measurement via V-Notch, well site with display board well cap, protection box activity for each Pz site, etc. The soft copy should be submitted. Summary of wells details in xls format (as per proforma given by CGWB) including details of dia and depth housing pipe, assembly pipe, screen pipe, static water level, TDS, aquifer parameters, safe discharge, gravel packing depth and thickness, Litholog etc should be also submitted.	31	Job		
	Construction Cost (A) in Rs				
	GST @ 18%				
	Grand Total (A+B) in Rs				
Notes					
1. The Pilot hole drilling should be carried out to target depth of 250m plus 5m or to the depth of bed rock whichever is early and shall be cross checked with logging depth from logging graph and in case of variation payment to pilot hole drilling shall be limited to logging depth.					
2. Reaming depth for should be total Pz depth plus 5m					
3. Total Reaming depth in a well shall not exceed total assembly depth plus 5m and payment shall be made as actual reaming depth or assembly depth plus 5m which ever is lower.					
4. No payment shall be made if well is abandoned without lowering assembly upto the recommended depth citing formation problem.					
5. No payment shall be made if any well is abandoned due to fault of contractor or due to machinery, bore hole fishing, etc citing formation problem except under extraordinary situations like interference/ objection by the Local Government Bodies or public agitation against drilling leading to law and order problems, etc.					
6. Logging should be carried out to target depth of 250m or to the depth of bedrock whichever is lower in all Pzs.					

<p>7. Payment for Gravel packing shall be in terms of meterage height measured from the bottom of Reamed depth. Also gravel in terms of volume consumed should be cross checked with theoretical volume of gravel packing to ensure there is no bridging during gravel packing. The actual volume of gravel used and theoretical annular volume gravel should be provided for each wells</p>
<p>*8. Water samples shall be collected as per the standard procedures at the closure of well development (in Pz) as per the standard procedures. Water samples will be collected in 3 pre-treated HDPE containers (1 no. of 1 litre capacity container for Basic parameters, 2nos. of 250ml/500ml capacity containers for heavy metals). The samples for arsenic parameter and Uranium should be acidified with ultrapure HCl (1:1 HCl) and the samples for other heavy/ trace metals should be acidified with ultrapure HNO3 (1:1 HNO3).</p>
<p>*9 All the collected water samples shall be submitted to CGWB and water samples should be properly sealed and labelled with the relevant details like location (including Lat and Long), well number and type, date and time of sampling, stage of pumping test/ well development, details of acidification, water temperature at the time of sample collection, etc.</p>
<p>10.Immediately afer lowering of assembly, gravel packing should be carried out immediately and and withing two days of lowering of assembly and gravel packing, using compressor, well should be developed , followed by other means of well development. Well development will be treated as completed only when water is clear and free of suspended particles . Well will be treated as completed only after construction of well as per the recommended well assembly and after conducting the well development, pumping test and all other items mentioned in the BOQ including logging, submission of BDRs duly validated by CGWB . Payment for the well shall be made only when the well is constructed as per the BOQ specification.</p>
<p>12. Summary of wellwise data i.e site location with latitude-longitude, pilot hole depth, pilot hole dia, logging depth as per graph, assembly dia and depth, gravel packing depth range, water quality parameter (to be analysed by CGWB), static water level, discharge, Transmissivity etc in xls as per proforma given by CGWB should be submitted on completion of all wells</p>
<p>13. Lithosamples collected at 3m interval (minimum 250 g per 3meter interval) as per BOQ should be properly packed in good quality plastic transparent bottles and should be tagged with details of sample No, site name, well type, depth range of litholog, etc and should be submitted to CGWB Regional office along with drill time log and logging details including logging graph.</p>

UP PZ BOQ 5

BOQ template for Uttar Pradesh (Soft Rock 250m)/ UP_NR_Pz_05			
PIEZOMETERS			
A	State		Uttar Pradesh
B	District		7 Districts
C	Number of Piezometers		14

E	Depth of Pilot Hole Piezometers		355 m
G	Average depth of casing		330 m
H	Diameter of pipe for casing		6 inch
I	Well Completion Depth of PZ		330 m
J	Diameter of intake pipe		150 mm
K	Length of intake pipe (blank)		315 m
L	Length of intake pipe (screen)		15 m
M	Type of screen	LCG	
N	Slot opening		0.75/1.00 mm
O	Development of Piezometer by air compressor		5 Hours/ Pz
P	Number of samples per well to be tested for Basic Parameters	number	1
Q	Number of samples per well to be tested for Heavy metals	number	1

BOQ FOR CONSTRUCTION OF PIEZOMETERS (350m) IN SOFT ROCK FORMATION IN UTTAR PRADESH

Sr. No.	Item of Work	Piezometers			
		Qty	Units	Unit Cost in Rs	Total Cost in Rs
1	Drilling of pilot hole for PZ not larger than 216mm (8 1/2 " by rock roller/ drag bit including sample collection and preparation of litholog	4970	Meter		
2	Electrical Logging using 406mm and 1626mm (16" and 64"), SP resistivity probe and Natural Gamma logging, preparation of litholog, submission of report including zone wise water quality along with logging graphs, composite log etc.	14	Job		
3	Enlargement of hole by reaming in PZ to accommodate well assembly of recommended size and gravel envelope of minimum 100 mm thickness as given below				
3.1	Using 250 mm (10") RR Bit for 100 mm(4") assembly pipe (for 100m depth Pzs)	0	Meter		
3.2	Using 317.5 mm (12-1/2") RR Bit for 150 mm(6") assembly pipe (For 250-350 m depth Pzs)	4690	Meter		

4	Supply and Installation of ERW casing pipe conforming to Table 3 of latest version of IS: 4270-2001 of diameter and thickness given below				
4.1	100mm (4") Nominal Bore thickness 5.4mm	0	Meter		
4.2	150mm (6") Nominal Bore thickness 5.4mm	4410	Meter		
6	Supply and installation of LCG V-wire screen conforming to latest version of IS: 8110-2000 of dimension given below				
6.1	100mm (4") Normal Size thickness 7mm with slot opening size given below				
6.1.1	Slot opening 0.75 mm	0	meter		
6.1.2.	Slot opening 1.0 mm	0	meter		
6.2	150mm (6") Normal Size thickness 7mm with slot opening size given below				
6.2.1.	Slot opening 0.75 mm	126	meter		
6.2.1.	Slot opening 1.0 mm	84	meter		
7	Supply and shrouding 01 pea gravel confirming to Latest version of IS: 4097-1967	0			
7.1	Particle size range 2.00 mm to 4.5 mm for 1.0 mm and 0.75 mm slot opening	260	CUM		
8	Supply and filling up borehole/ annular space between casing pipe and bore hole wall with local clay, if required	0	Job		
9	Collection of Water Samples during compressor development and analysis of the sample				
9.1.	Chemical analysis of water samples for 15 parameters pH, EC, TH, TDS, Ca, Mg, Na, K, CO ₃ , HCO ₃ , SO ₄ , NO ₃ , Cl, F & Fe in NABL accredited labs	14	Job		
9.2.	Chemical analysis of water samples for Heavy metals (As, Pb, Zn, Cu, Cr, Se, Ni, Mn, U) in NABL accredited labs and submission of report from NABL accredited lab	14	Job		

10	Deployments by Air Compressor of adequate capacity for minimum 10 hours till discharge water is clear and free of sand including collection of water samples from PZ. Collection of Water samples as per prescribed format mentioned below.	14	Job		
11	Supply and fitting of well cap as per drawing with allen keys. MS plate size 5mm embossed and welded with permanent marking by welded method as "CGWB_Pz_Depth".				
11.1.	For 4" dia Piezometers	0	Job		
11.2	For 6" dia Piezometers	14	Job		
12	Construction of Cement concrete platform 0.7*0.7*0.6 m (0.3 m above ground level) using concrete mix of 1:2:4 around the pipe welded minimum 6 ns of anchoring plate as per drawing	14	Job		
13	Supply and installation of display board as per drawing	14	Job		
14	Supply and installation of protection box along with brass lock (7lever hardened) and three keys for each lock as per drawing	14	Job		
15	Preparation and submission of basic data report per site in triplicate along with logging graphs, data sheets, analysis sheet, logging graphs, chemical analysis report from NABL lab, site location map and approachability with land marks, photographs and videos of activities of drilling, assembly lowering, gravel measurement and gravel packing, well development using compressor and well water discharge, water sample collection during compressor development, well discharge with discharge measurement via V-Notch, well site with display board well cap, protection box activity for each Pz site, etc. The soft copy should be submitted. Summary of wells details in xls format (as per proforma given by CGWB) including details of dia and depth housing pipe, assembly pipe, screen pipe, static water level, TDS, aquifer parameters, safe discharge, gravel packing depth and thickness, Litholog etc should be also submitted.	14	Job		

	Construction Cost (A) in Rs				
	GST @ 18%				
	Grand Total (A+B) in Rs				
Notes					
1. The Pilot hole drilling should be carried out to target depth of 350m plus 5m or to the depth of bed rock whichever is early and shall be crossed checked with logging depth from logging graph and in case of variation payment to pilot hole drilling shall be limited to logging depth.					
2. Reaming depth for should be total Pz depth plus 5m					
3. Total Reaming depth in a well shall not exceed total assembly depth plus 5m and payment shall be made as actual reaming depth or assembly depth plus 5m which ever is lower.					
4. No payment shall be made if well is abandoned without lowering assembly upto the recommended depth citing formation problem.					
5. No payment shall be made if any well is abandoned due to fault of contractor or due to machinery, bore hole fishing, etc citing formation problem except under extraordinary situations like interference/ objection by the Local Government Bodies or public agitation against drilling leading to law and order problems, etc.					
6. Logging should be carried out to target depth of 350m or to the depth of bedrock whichever is lower in all Pzs.					
7. Payment for Gravel packing shall be in terms of meterage height measured from the bottom of Reamed depth. Also gravel in terms of volume consumed should be cross checked with theoretical volume of gravel packing to ensure there is no bridging during gravel packing. The actual volume of gravel used and theoretical annular volume gravel should be provided for each wells					
*8. Water samples shall be collected as per the standard procedures at the closure of well development (in Pz) as per the standard procedures. Water samples will be collected in 3 pre-treated HDPE containers (1 no. of 1 litre capacity container for Basic parameters, 2nos. of 250ml/500ml capacity containers for heavy metals). The samples for arsenic parameter and Uranium should be acidified with ultrapure HCl (1:1 HCl) and the samples for other heavy/ trace metals should be acidified with ultrapure HNO3 (1:1 HNO3).					
*9 All the collected water samples shall be submitted to CGWB and water samples should be properly sealed and labelled with the relevant details like location (including Lat and Long), well number and type, date and time of sampling, stage of pumping test/ well development, details of acidification, water temperature at the time of sample collection, etc.					

<p>10. Immediately after lowering of assembly, gravel packing should be carried out immediately and within two days of lowering of assembly and gravel packing, using compressor, well should be developed, followed by other means of well development. Well development will be treated as completed only when water is clear and free of suspended particles. Well will be treated as completed only after construction of well as per the recommended well assembly and after conducting the well development, pumping test and all other items mentioned in the BOQ including logging, submission of BDRs duly validated by CGWB. Payment for the well shall be made only when the well is constructed as per the BOQ specification.</p>
<p>12. Summary of wellwise data i.e site location with latitude-longitude, pilot hole depth, pilot hole dia, logging depth as per graph, assembly dia and depth, gravel packing depth range, water quality parameter (to be analysed by CGWB), static water level, discharge, Transmissivity etc in xls as per proforma given by CGWB should be submitted on completion of all wells</p>
<p>13. Lithosamples collected at 3m interval (minimum 250 g per 3meter interval) as per BOQ should be properly packed in good quality plastic transparent bottles and should be tagged with details of sample No, site name, well type, depth range of litholog, etc and should be submitted to CGWB Regional office along with drill time log and logging details including logging graph.</p>

BOQ for Odisha State

OD PZ BOQ 1

BOQ for Odisha (OD_SER_SR01)			
Alluvium Formation piezometers			
Bidder Name			
SoftRockWells			Type I
	State	Odisha	
1	Number of piezometers	15	number
2	Number of shiftings involved	15	number
3	Depth of pilot hole (152 m dia.)	75	meter
4	Average depth of well construction	70	meter
5	Diameter of intake pipe	102	mm
6	Length of intake pipe (blank)	55	meter
7	Length of intake pipe (screen)	15	meter
8	Type of screen	MS	
8.1	Slot opening	1.5	mm
9	Development of piezometer well by air compressor	5	hours
10	Chemical analysis of water samples for basic parameters	15	number

11	Chemical analysis of water samples for Heavy metals	15	number
12	Collection of water samples per piezometer	2	number
13	Other Activities: Number of piezometers where the activity may be needed		
13.1	Number of piezometers where cement sealing may be required	0	number
13.2	Average depth of location of top-most cement seal		meter

piezometers					
S. No.	Item of work	Unit	EW Qty	Rate per unit in INR (in figures) excluding GST	Total Rate INR (in figures)
1	Drilling of pilot hole not larger than 152 mm (6") by rock roller/ drag bit including sample collection and preparation of litholog	meter	1125		
2	Electrical logging using 406 mm and 1626 mm (16" and 64") SP resistivity probe and preparation of composite log	number	15		
3	Supply and installation of ERW casing pipe 102 mm (4") Nominal Bore, conforming to Table 3 of latest version of IS: 4270-2001	meter	825		
4	Supply and installation of MS slotted pipes of 100 mm (4") Nominal Size, thickness 5.4mm with slot opening size 1.5 mm, conforming to sizes as per Table 1 with slotting arrangement shown in Figure 2 of latest version of IS: 8110-2000")	meter	225		
5	Supply and shrouding of pea gravel confirming to latest version of IS: 4097-1967 with Particle size range 3.35 mm to 4.75 mm for 1.5 mm slot openingly	Cubic meter	41.87		
6	Cement sealing	job	0		

7	Supply and filling up borehole/ annular space between casing pipe and bore hole wall with local clay, if required	cubic meter	0		
8	Development by Air Compressor of adequate capacity for minimum 5 hours, over pumping and by other means till discharge water is clear and free of sand including collection of two water samples from PZ well adopting standard procedure in 1 litre HDPE bottle, along with video recordings of compressor hour meter, discharge etc.	Job	15		
9	Chemical analysis of water samples for 15 parameters pH, EC, TH, TDS, Ca, Mg, Na, K, CO ₃ , HCO ₃ , SO ₄ , NO ₃ , Cl, F & Fe in NABL accredited labs and submission of report from NABL lab	Job	15		
10	Chemical analysis of water samples for Heavy metals (Arsenic and Uranium) in NABL accredited labs and submission of report from NABL lab	job	15		
11	Construction of cement concrete platform of dimension 0.70 X 0.70 X 0.60 m (0.30 m above ground level) using concrete mix of 1:2:4 around the Piezometer well welded with minimum 6 Nos. of anchoring plate as per drawing.	number	15		

12	Supply and installation of protection box made of 3 mm GI sheet of Size: 550mm X450mm X530mm along with Brass lock (7 lever hardened) and three keys for each lock as per drawing with well cap	number	15		
13	Supply and installation of Display board as per specification in drawing	number	15		
14	Preparation and submission of basic data report for each site in triplicate along with data sheets, analysis sheet, chemical analysis report from NABL lab, site location map and approachability with land marks etc. photographs and videos of all activities shall be submitted along with BDRs. The BDR containing all details as per Format shall be submitted	number	15		
Grand Total					
GST @ 18%					
Grand Total inclusive of Taxes					
Say (rounded to 1000)					

Note

1. Payment shall be made based on actual executed quantities of each item at site.
2. The payment of pipe shall be made based on actual consumptions of pipes
3. The pipes shall be supplied by the bidder as per technical specification given by PMC.
4. Need based quantity shall be decided as per requirement at site by PMC under intimation to CGWB officials at site.
5. If the additional quantity of any item is needed as per technical requirement at site, the same shall be decided by CGWB & PMC.

OD PZ BOQ 2

BOQ for Odisha (OD_SER_SR02)					
Alluvium Formation piezometers					
Bidder Name					
SoftRockWells			Type II		
	State	Odisha			
1	Number of piezometers	2	number		
2	Number of shiftings involved	2	number		
3	Depth of pilot hole (152 m dia.)	260	meter		
4	Average depth of well construction	255	meter		
5	Diameter of intake pipe	102	mm		
6	Length of intake pipe (blank)	225	meter		
7	Length of intake pipe (screen)	30	meter		
8	Type of screen	MS			
8.1	Slot opening	1.5	mm		
9	Development of exploratory well by air compressor	10	hours		
10	Chemical analysis of water samples for basic parameters	2	number		
11	Chemical analysis of water samples for Heavy metals	2	number		
12	Collection of water samples per piezometers	2	number		
13	Other Activities: Number of piezometer where the activity may be needed				
13.1	Number of piezometers where cement sealing may be required	2	number		
13.2	Average depth of location of top-most cement seal	200	meter		
piezometers					
S. No.	Item of work	Unit	EW Qty	Rate per unit in INR (in figures) excluding GST	Total Rate INR (in figures)
2	Drilling of pilot hole not larger than 152 mm (6") by rock roller/ drag bit including sample	meter	520		

	collection and preparation of litholog				
3	Electrical logging using 406 mm and 1626 mm (16" and 64") SP resistivity probe and preparation of composite log	number	2		
4	Supply and installation of ERW casing pipe 102 mm (4") Nominal Bore, conforming to Table 3 of latest version of IS: 4270-2001	meter	450		
5	Supply and installation of MS slotted pipes of 100 mm (4") Nominal Size, thickness 5.4mm with slot opening size 1.5 mm, conforming to sizes as per Table 1 with slotting arrangement shown in Figure 2 of latest version of IS: 8110-2000")	meter	60		
6	Supply and shrouding of pea gravel conforming to latest version of IS: 4097-1967	Cubic meter	20.34		

	with Particle size range 3.35 mm to 4.75 mm for 1.5 mm slot openingly				
7	Cement sealing	job	2		
8	Supply and filling up borehole/ annular space between casing pipe and bore hole wall with local clay, if required	cubic meter	0		
9	Development by Air Compressor of adequate capacity for minimum 10 hours, over pumping and by other means till discharge water is clear and free of sand including collection of two water samples from PZ well adopting standard procedure in 1 litre HDPE bottle, along with video recordings of compressor hour meter, discharge etc.	Job	2	50000	100000

10	Chemical analysis of water samples for 15 parameters pH, EC, TH, TDS, Ca, Mg, Na, K, CO ₃ , HCO ₃ , SO ₄ , NO ₃ , Cl, F & Fe in NABL accredited labs and submission of report from NABL lab	Job	2	2000	4000
11	Chemical analysis of water samples for Heavy metals (Arsenic and Uranium) in NABL accredited labs and submission of report from NABL lab	job	2	1500	3000
12	Construction of cement concrete platform of dimension 0.70 X 0.70 X 0.60 m (0.30 m above ground level) using concrete mix of 1:2:4 around the Piezometer well welded with minimum 6 Nos. of anchoring plate as per drawing.	number	2	8000	16000

13	Supply and installation of protection box made of 3 mm GI sheet of Size: 550mm X450mm X530mm along with Brass lock (7 lever hardened) and three keys for each lock as per drawing with well cap	number	2	15000	30000
14	Supply and installation of Display board as per specification in drawing	number	2	10000	20000
15	Preparation and submission of basic data report for each site in triplicate along with data sheets, analysis sheet, chemical analysis report from NABL lab, site location map and approachability with land marks etc. photographs and videos of all activities shall be submitted along with BDRs. The BDR containing all details as per Format shall be submitted	number	2	8000	16000
Grand Total					
GST @ 18%					

Grand Total inclusive of Taxes				
Say (rounded to 1000)				

Note

1. Payment shall be made based on actual executed quantities of each item at site.
2. The payment of pipe shall be made based on actual consumptions of pipes
3. The pipes shall be supplied by the bidder as per technical specification given by PMC.
4. Need based quantity shall be decided as per requirement at site by PMC under intimation to CGWB officials at site.
5. If the additional quantity of any item is needed as per technical requirement at site, the same shall be decided by CGWB & PMC.

OD PZ BOQ 3

BOQ for PZs State Odisha (OD_SER_HR 03)

HardRockWells		Type			
1	State(s)			Odisha	
2	Number of Piezometers		17	number	
3	Depth of piezometers		100	m	
4	Average depth of overburden		20	m	
5	Drilling diameter in over-burden		152	mm	
6	Diameter of pipe for casing of overburden		152	mm	
7	Drilling diameter in hard rock		102	mm	
8	Collection of water samples per site		2	number	
9	Number of samples per well to be tested for Basic Paramers		1	number	
10	Number of samples per well to be tested for Heavy metals		1	number	

No cell should be left blank. Leaving any cell blank will result in taking that value as zero, but it will not be clear whether it was intended to be zero or has been left blank by mistake.

**BOQ for Construction of piezometers in hard rock areas of in Odisha
2022-23**

S. No	Item of Work	PZ (100m)			
		Qty	Unit	Unit Cost (Excluding GST)	Total Cost (PZ) (Excluding GST)
1	Drilling of overburden by rock roller/ drag/ button bit to accommodate casing pipe including sample collection, preparation and submission of litholog with video recordings of bit lowering, pull out after completion of overburden drilling, casing pipe lowering, discharge if any during overburden drilling etc.	340	meter		
2	Supply and installation of ERW casing pipe conforming to latest version of IS: 4270-2001				
2.1	152 mm (6") Nominal Bore ,thickness 5.4mm	348.5	meter		
3	Drilling by DTH method using appropriate sizes of button bits so as to reach targeted depth with diameter of hole not less than 102 mm at 100 m depth with the casing diameter not less than 152 mm, formation sample collection at every 3 meter intervals, preparation and submission of litholog	1360	meter		
4	Caliper logging to decipher the depth and width of fracture zones, submission of report including logging graph, interpretation of graph, generation of composite log along with video recording	17	job		
5	Chemical analysis of water samples for 15 parameters pH, EC, TH, TDS, Ca, Mg, Na, K, CO ₃ , HCO ₃ , SO ₄ , NO ₃ , Cl, F & Fe in NABL accredited labs and submission of report from NABL lab	17	job		
6	Chemical analysis of water samples for Heavy metals (Arsenic and Uranium) in NABL accredited labs and submission of report from NABL lab	17	job		
7	Construction of cement concrete platform of dimension 0.70 X 0.70 X 0.60 m (0.30 m above ground level) using concrete mix of 1:2:4 around the housing pipe welded with minimum 6 Nos of anchoring plate as per drawing	17	job		

8	Supply and installation of protection box made of 3 mm GI sheet of Size: 550mm X450mm X530mm along with Brass lock (7 lever hardened) and three keys for each lock as per drawing with well cap	17	job		
9	Supply and installation of Display board as per specification in drawing	17	number		
10	Preparation and submission of basic data report for each site in triplicate along with data sheets, analysis sheet, chemical analysis report from NABL lab, site location map and approachability with land marks etc. photographs and videos of all activities shall be submitted along with BDRs. The BDR containing all details as per Format shall be submitted	17	number		
	Total				
	GST @ 18%				
	Grand Total inclusive of Taxes				
	Say (rounded to 1000)				

Note:

- 2 The average overburden thickness is 20m and may vary upto a maximum thickness of 50m in few wells.
- 3 Combination rig using DTH method and direct rotary method shall be required for construction of well. The contractor should have sufficient expertise to tackle formation problem like caving, air loss, negative zone etc. and should adopt appropriate methods to overcome formation problems encountered during drilling and should be able to construct well successfully to target depth. The price of BOQ items deems to cover formation problem encountered during drilling and no payment shall be paid for tackling formation problem.
- 4 Water samples shall be collected as per the standard sampling procedures (pre-treated HDPE containers) for each piezometer during drilling if discharge is less than 1 lps and not suitable for carrying out PYT, and should be collected during PYT in other suitable wells. One sample each for analysis of basic parameters and heavy metals should be collected. The samples for heavy/ trace metals should be acidified with ultrapure HNO₃ (1:1 HNO₃).
- 5 No payment shall be made if any well is abandoned before completion of lowering of casing pipe upto entire thickness of overburden or well is abandoned before 50m depth.
- 6 No payment shall be made if any well is abandoned due to fault of contractor or due to machinery, bore hole fishing, etc citing formation problem except under extraordinary situations like interference/ objection by the Local Government Bodies or public agitation against drilling leading to law and order problems, etc.

- 7 All wells should be constructed to target depth of 100m. In case target depth is not achieved citing formation problem/technical problems, payment shall be made at the 50% of unit price of executed quantity. The total depth of well shall be cross checked by CGWB officers. Payment shall be made as per actual depth measured during handing over of well.
- 8 Litholog collected (minimum 250 g) as per BOQ should be properly packed in good quality packing cover and should be tagged with details of sample No, site name, well type, depth range of litholog, etc and should be submitted to CGWB Regional office along with drill time log.
- 9 The well shall be treated as complete only when all items of BOQ are executed and the well is completed to target depth successfully and handed over to CGWB along with the BDR duly validated by the Regional Director.

BOQ for West Bengal State

WB PZ BOQ 1

BOQ Template for Piezometer construction of West Bengal (Soft Rock 150 m)						
Soft Rock (Shallow Piezometers)				Shallow (Soft Rock)		
State(s) West Bengal (AAP 2022-23)						
Number of Piezometers				104	number	
Depth of pilot hole				155	meter	
Average depth of well construction				150	meter	
Diameter of housing pipe (ID)				100	mm	
Length of housing pipe (should be left blank if the diameter of housing and intake pipe is same)					meter	
Diameter of intake pipe				100	mm	
Average Length of intake pipe				120	meter	
Average Length of intake pipe (screen), Type of screen Stainless steel of SS304 grade				30	meter	
Slot opening				0.75	mm	
Average Development of Piezometer by air compressor				5	hours	
Collection of water samples per site				2	number	
Number of samples per well to be tested for Basic Parameters				1	number	
Number of samples per well to be tested for Heavy Metals				1	number	
S. No.	Item of work	Unit	Rate/ Unit Quantity (Excluding GST)	Total Meterage/Total no.	Total Amount (Excluding GST)	

1	Drilling of pilot hole using bentonite fluid for PZ not larger than 216 mm (8 ½") by rock roller/ drag bit including formation sample collection at every 3m and change in formation , preparation and submission of litholog along with video recording	meter		16120	
2	Electrical logging using 406 mm and 1626 mm (16" and 64") SP resistivity probe, Natural Gamma Logging to target depth of max. 155 m, submission of report including zone-wise water quality, logging graph, interpretation of graph, generation of composite log along with video recording	job		104	
3	Enlargement of hole by reaming in Piezometer to accommodate well assembly of recommended size and gravel envelop of minimum 100 mm thickness as given below	job			

3.1	Using 311.15 mm (12-1/4") RR Bit for 100 mm (4") assembly pipe	meter		16120	
4	Supply and installation of ERW casing pipe conforming to latest version of IS: 4270-2001 of diameter and thickness given below				
4.1	100 mm (4") Nominal Bore, thickness of casing pipe: 5.4 mm	meter		12480	
5	Supply and installation of Stainless Steel 4"(100 mm) dia. x 1.5 mm slot size regular Grade SS304 Grade Wire screen as per IS:8110-95 and material specifications, suitable for water well construction (recommended based on prevailing hydrogeological and hydrochemical conditions in West Bengal)				
5.1	Slot opening 0.75 mm (Stainless Steel SS304 Grade Wire screen)	meter		3120	
6	Supply and shrouding of pea gravel confirming to				

	latest version of IS: 4097-1967				
6.1	Particle size range 2.00 mm to 3.35 mm for 1.0 mm and 0.75 mm slot opening	cu meter		624	
7	Supply and filling up borehole/ annular space between casing pipe and bore hole wall with local clay, if required	job		104	
8	Development by Air Compressor of adequate capacity for minimum 5 hours, over pumping and by other means till discharge water is clear and free of sand including collection of two water samples from PZ well adopting standard procedure in 1 litre HDPE bottle, along with video recordings of compressor hour meter, discharge etc.	job		104	
9	Chemical analysis of water samples for 15 parameters (pH, EC, TH, TDS, Ca, Mg, Na, K, CO ₃ , HCO ₃ , SO ₄ , NO ₃ , Cl, F & Fe) in NABL accredited labs	job		104	

10	Chemical analysis of water samples for Heavy metals (As, U) in NABL accredited labs and submission of report from NABL accredited lab	job		104	
11	Construction of cement concrete platform of dimension 0.70 X 0.70 X 0.60 m (0.30 m above ground level) using concrete mix of 1:2:4 around the Piezometer well welded with minimum 6 Nos of anchoring plate as per drawing	job		104	
12	Supply and fitting of well cap as per drawing with Allen Keys. MS Plate size 5 mm embossed & welded with permanent marking of "CGWB PZ" should be carved with welding on outer surface of casing pipe	job		104	
13	Supply and installation of protection box made of 3 mm GI sheet of Size: 550mm X450mm X530mm along with Brass lock (7 lever	job		104	

	hardened of reputed brand) and three keys for each lock as per drawing				
14	Supply and installation of Display Board as per drawing	job		104	
15	Preparation and submission of basic data report per site in triplicate along with data sheets, analysis sheet, chemical analysis report from NABL lab, site location map and approachability with landmarks, photographs and videos of activities of drilling, assembly lowering, gravel measurement and gravel packing, well development using compressor and well water discharge, water sample collection, well discharge with discharge measurement, well site with display board, well cap, protection box for each site, etc.The soft copy as well as hard copy should be submitted. Summary of Piezometer details in xls format (as per proforma given by CGWB) including details of dia and depth of assembly pipe, screen pipe, static water level, gravel packing depth and thickness, Litholog etc. should be also submitted.	job		104	
	Total (excluding GST)				

- | | | | | | |
|--|--|--|--|--|--|
| | | | | | |
|--|--|--|--|--|--|
- Note:**
1. The Pilot Hole drilling should be carried out to target depth of 150 m plus 5 m **or to the depth of bed rock.**
 2. Reaming depth for Housing pipe shall be Housing depth plus 5 m.
 3. Total Reaming depth in a well shall not exceed total assembly depth plus 5 m and payment shall be made as actual reaming depth or assembly depth plus 5 m whichever is less.
 4. No payment shall be made if well is abandoned without lowering assembly upto the recommended depth citing formation problem.
 5. No payment shall be made if any well is abandoned due to fault of contractor or due to machinery, bore hole fishing, etc citing formation problem except under extraordinary situations like interference/ objection by the Local Government Bodies or public agitation against drilling leading to law and order problems, etc.
 6. Payment for gravel packing shall be in terms of meterage height measured from the bottom of Reamed depth. Also gravel in terms of volume consumed should be cross checked with theoretical volume of gravel packing to ensure there is no bridging during gravel packing. The actual volume of gravel used and theoretical annular volume of gravel should be provided for each wells.
 7. Water samples shall be collected as per the standard procedures at the closure of well development as per the standard procedures. Water samples will be collected in 3 pre-treated HDPE containers (1 no. of 1 litre capacity container for basic parameters, 2 nos. of 500 ml capacity containers for heavy metals). The samples for arsenic parameter should be acidified with ultrapure HCl (1:1 HCl) and the samples for other heavy/ trace metals should be acidified with ultrapure HNO₃ (1:1 HNO₃).
 8. All the collected water samples shall be submitted to CGWB and water samples should be properly sealed and labelled with the relevant details like location (including Lat and Long), well number and type, date and time of sampling, stage of pumping test/ well development, details of acidification, water temperature at the time of sample collection, etc.
 9. The water samples collected at the last stage of well development in case of Piezometer shall be analysed for basic parameters and heavy metals as per BOQ by the contractor through NABL Lab and one more set of these water samples shall be submitted to CGWB for validation along with original report of NABL Lab.
 10. Well development will be treated as completed only when water is clear and free of suspended particles during pumping. Well will be treated as completed only after construction of well as per the recommended well assembly and after conducting the well development and all other items mentioned in the BOQ including logging, submission of BDRs duly validated by CGWB. Payment for the well shall be made only when the well is constructed as per the BOQ specification.
 11. Litholog collected (minimum 250 g) as per BOQ should be properly packed in good quality packing cover and should be tagged with details of sample No, site name, well type, depth range of litholog, etc and should be submitted to CGWB Regional office along with drill time log and logging details including logging graph.
 12. If additional quantity of any item is needed as per technical requirement at site, the same shall be decided by CGWB, ER in concurrence with the PMC, CGWB, CHQ.
 13. **CGWB, CHQ / CGWB, ER will not be responsible for any site related issues like rig / manpower, transportation, local disputes etc. at any point of time.**

WB PZ BOQ 2

BOQ Template for Piezometer construction of West Bengal (Soft Rock 300 m)					
Soft Rock (Deep Piezometers)				Deep (Soft Rock)	
State(s) West Bengal (AAP 2022-23)					
Number of Piezometers				27	number
Depth of pilot hole				305	meter
Average depth of well construction				300	meter
Diameter of housing pipe (ID)				100	mm
Length of housing pipe (should be left blank if the diameter of housing and intake pipe is same)					meter
Diameter of intake pipe				100	mm
Average Length of intake pipe (screen)				30	meter
Average Length of intake pipe (screen), Type of screen Stainless steel of SS304 grade				SS304	
Slot opening				0.75	mm
Average Development of Piezometer by air compressor				10	hours
Collection of water samples per site				2	number
Number of samples per well to be tested for Basic Parameters				1	number
Number of samples per well to be tested for Heavy Metals				1	number
S. No.	Item of work	Unit	Rate/ Unit Quantity (Excluding GST)	Total Meterage/Total no.	Total Amt. (Excluding GST)
1	Drilling of pilot hole using bentonite fluid for PZ not larger than 216 mm (8 ½”) by rock roller/ drag bit including formation sample collection at every 3m and change in formation , preparation and submission of litholog along	meter		8235	

	with video recordings				
2	Electrical logging using 406 mm and 1626 mm (16" and 64") SP resistivity probe, Natural Gamma Logging to target depth of max. 155 m, submission of report including zone-wise water quality, logging graph, interpretation of graph, generation of composite log along with video recording	job		27	
3	Enlargement of hole by reaming in Piezometer to accommodate well assembly of recommended size and gravel envelop of minimum 100 mm thickness as given below	job			
3.1	Using 311.15 mm (12-1/4") RR Bit for 100 mm (4") assembly pipe	meter		8235	
4	Supply and installation of ERW casing pipe conforming to latest version of IS: 4270-2001 of diameter and thickness given				

	below				
4.1	100 mm (4") Nominal Bore, thickness of casing pipe: 5.4 mm	meter		7290	
5	Supply and installation of Stainless Steel 4"(100 mm) dia. x 1.5 mm slot size regular Grade SS304 Grade Wire screen as per IS:8110-95 and material specifications, suitable for water well construction (recommended based on prevailing hydrogeological and hydrochemical conditions in West Bengal)				
5.1	Slot opening 0.75 mm (Stainless Steel SS304 Grade Wire screen)	meter		810	
6	Supply and shrouding of pea gravel confirming to latest version of IS: 4097-1967				
6.1	Particle size range 2.00 mm to 3.35 mm for 1.0 mm and 0.75 mm slot opening	cu meter		463	
7	Supply and filling up borehole/	job		27	

	annular space between casing pipe and bore hole wall with local clay, if required				
8	Development by Air Compressor of adequate capacity for minimum 10 (ten) hours, over pumping and by other means till discharge water is clear and free of sand including collection of two water samples from PZ well adopting standard procedure in 1 litre HDPE bottle, along with video recordings of compressor hour meter, discharge etc.	job		27	
9	Chemical analysis of water samples for 15 parameters (pH, EC, TH, TDS, Ca, Mg, Na, K, CO ₃ , HCO ₃ , SO ₄ , NO ₃ , Cl, F & Fe) in NABL accredited labs	job		27	
10	Chemical analysis of water samples for Heavy metals (As, U) in NABL accredited labs and submission of report from NABL accredited lab	job		27	

11	Construction of cement concrete platform of dimension 0.70 X 0.70 X 0.60 m (0.30 m above ground level) using concrete mix of 1:2:4 around the Piezometer well welded with minimum 6 Nos of anchoring plate as per drawing	job		27	
12	Supply and fitting of well cap as per drawing with Allen Keys. MS Plate size 5 mm embossed & welded with permanent marking of "CGWB PZ" should be carved with welding on outer surface of casing pipe.	job		27	
13	Supply and installation of protection box made of 3 mm GI sheet of Size: 550mm X450mm X530mm along with Brass lock (7 lever hardened of reputed brand) and three keys for each lock as per drawing	job		27	
14	Supply and installation of Display Board as per drawing	job		27	

15	Preparation and submission of basic data report per site in triplicate along with data sheets, analysis sheet, chemical analysis report from NABL lab, site location map and approachability with landmarks, photographs and videos of activities of drilling, assembly lowering, gravel measurement and gravel packing, well development using compressor and well water discharge, water sample collection, well discharge with discharge measurement, well site with display board, well cap, protection box for each site, etc. The soft copy as well as hard copy should be submitted. Summary of Piezometer details in xls format (as per proforma given by CGWB) including details of dia and depth of assembly pipe, screen pipe, static water level, gravel packing depth and thickness, Litholog etc. should be also submitted.	job		27	
	Total (excluding GST)				

- Note:**
1. The Pilot Hole drilling should be carried out to target depth of 300 m plus 5 m **or to the depth of bed rock.**
 2. Reaming depth for Housing pipe shall be Housing depth plus 5 m.
 3. Total Reaming depth in a well shall not exceed total assembly depth plus 5m and payment shall be made as actual reaming depth or assembly depth plus 5m whichever is less.

4. No payment shall be made if well is abandoned without lowering assembly upto the recommended depth citing formation problem.

5. No payment shall be made if any well is abandoned due to fault of contractor or due to machinery, bore hole fishing, etc citing formation problem except under extraordinary situations like interference/ objection by the Local Government Bodies or public agitation against drilling leading to law and order problems, etc.

6. Payment for gravel packing shall be in terms of meterage height measured from the bottom of Reamed depth. Also gravel in terms of volume consumed should be cross checked with theoretical volume of gravel packing to ensure there is no bridging during gravel packing. The actual volume of gravel used and theoretical annular volume of gravel should be provided for each wells

7. Water samples shall be collected as per the standard procedures at the closure of well development as per the standard procedures. Water samples will be collected in 3 pre-treated HDPE containers (1 no. of 1 litre capacity container for basic parameters, 2 nos. of 500 ml capacity containers for heavy metals). The samples for arsenic parameter should be acidified with ultrapure HCl (1:1 HCl) and the samples for other heavy/ trace metals should be acidified with ultrapure HNO₃ (1:1 HNO₃).

8. All the collected water samples shall be submitted to CGWB and water samples should be properly sealed and labelled with the relevant details like location (including Lat and Long), well number and type, date and time of sampling, stage of pumping test/ well development, details of acidification, water temperature at the time of sample collection, etc.

9. The water samples collected at the last stage of well development in case of Piezometer shall be analysed for basic parameters and heavy metals as per BOQ by the contractor through NABL Lab and one more set of these water samples shall be submitted to CGWB for validation along with original report of NABL Lab.

10. Well development will be treated as completed only when water is clear and free of suspended particles during pumping. Well will be treated as completed only after construction of well as per the recommended well assembly and after conducting the well development and all other items mentioned in the BOQ including logging, submission of BDRs duly validated by CGWB . Payment for the well shall be made only when the well is constructed as per the BOQ specification.

11. Litholog collected (minimum 250 g) as per BOQ should be properly packed in good quality packing cover and should be tagged with details of sample No, site name, well type, depth range of litholog, etc and should be submitted to CGWB Regional office along with drill time log and logging details including logging graph.

12. If additional quantity of any item is needed as per technical requirement at site, the same shall be decided by CGWB, ER in concurrence with the PMC, CGWB, CHQ.

13. CGWB, CHQ / CGWB, ER will not be responsible for any site related issues like rig / manpower, transportation, local disputes etc. at any point of time.

WB PZ BOQ 3

BOQ Template for Piezometer construction of West Bengal (Bouldery Formation, 150 m)		
Piezometers in Soft Rock (Bouldery Formation)		Shallow (Bouldery)
State(s) West Bengal (AAP 2022-23)		
Number of Piezometers	17	number

Depth of pilot hole			155	meter	
Average depth of well construction			150	meter	
Diameter of housing pipe (ID)			100	mm	
Length of housing pipe (should be left blank if the diameter of housing and intake pipe is same)				meter	
Diameter of intake pipe			100	mm	
Average Length of intake pipe (screen), Type of screen Stainless steel of SS304 grade			12	meter	
Slot opening			1.5	mm	
Average Development of Piezometer by air compressor			5	hours	
Collection of water samples per site			2	number	
Number of samples per well to be tested for Basic Parameters			1	number	
Number of samples per well to be tested for Heavy Metals			1	number	
S. No.	Item of work	Unit	Rate/ Unit Quantity (Excluding GST)	Total Meterage/Total no.	Total Amt. (Excluding GST)
1	Drilling of pilot hole using ODEX method by ODEX 190/ ODEX 165 to the targeted depth 155 m so as to enable lowering 4" dia assembly pipe through 6"/5" dia casing including formation sample collection at every 3 m and change in formation, preparation and submission of litholog along with video recording	meter		2635	

2	Electrical logging using 406 mm and 1626 mm (16" and 64") SP resistivity probe, Natural Gamma Logging to target depth of max. 155 m, submission of report including zone-wise water quality, logging graph, interpretation of graph, generation of composite log along with video recording	job		17	
4	Supply and installation of ERW casing pipe(bead free)/ seamless conforming to latest version of IS: 4270-2001 of diameter and thickness given below				
4.1	150 mm (6") Nominal Bore, thickness of casing pipe: 7.1 mm	meter		2346	
5	Supply and installation of Stainless Steel 4"(100 mm) dia. x 1.5 mm slot size regular Grade SS304 Grade Wire screen as per IS:8110-95 and material specifications, suitable for water well construction				

	(recommended based on prevailing hydrogeological and hydrochemical conditions in West Bengal)				
5.1	Slot opening 1.5 mm	meter		204	
6	Supply and shrouding of pea gravel confirming to latest version of IS: 4097-1967				
6.1	Particle size range 3.35 mm to 4.75 mm for 1.5 mm slot opening	cu meter		34	
7	Supply and filling up borehole/ annular space between casing pipe and bore hole wall with local clay, if required	job		17	
8	Development by Air Compressor of adequate capacity for minimum 5 hours, over pumping and by other means till discharge water is clear and free of sand including collection of two water samples from PZ well adopting standard procedure in 1	job		17	

	litre HDPE bottle, along with video recordings of compressor hour meter, discharge etc.				
9	Chemical analysis of water samples for 15 parameters (pH, EC, TH, TDS, Ca, Mg, Na, K, CO ₃ , HCO ₃ , SO ₄ , NO ₃ , Cl, F & Fe) in NABL accredited lab	job		17	
10	Chemical analysis of water samples for Heavy metals (As, U) in NABL accredited labs and submission of report from NABL accredited lab	job		17	
11	Construction of cement concrete platform of dimension 0.70 X 0.70 X 0.60 m (0.30 m above ground level) using concrete mix of 1:2:4 around the Piezometer well welded with minimum 6 Nos of anchoring plate as per drawing	job		17	

12	Supply and fitting of well cap as per drawing with Allen Keys. MS Plate size 5 mm embossed & welded with permanent marking of "CGWB PZ" should be carved with welding on outer surface of casing pipe.	job		17	
13	Supply and installation of protection box made of 3 mm GI sheet of Size: 550 mm X 450 mm X 530 mm along with Brass lock (7 lever hardened of reputed brand) and three keys for each lock as per drawing	job		17	
14	Supply and installation of Display Board as per drawing	job		17	

15	<p>Preparation and submission of basic data report per site in triplicate along with data sheets, analysis sheet, chemical analysis report from NABL lab, site location map and approachability with landmarks, photographs and videos of activities of drilling, assembly lowering, gravel measurement and gravel packing, well development using compressor and well water discharge, water sample collection, well discharge with discharge measurement, well site with display board, well cap, protection box for each site, etc. The soft copy as well as hard copy should be submitted.</p> <p>Summary of Piezometer details in xls format (as per proforma given by CGWB) including details of dia and depth of assembly pipe, screen pipe, static water level, gravel packing depth and thickness, litholog etc. should be also submitted.</p>	job		17	
	Total (excluding GST)				
	Average rate per Piezometer (Bouldery Formation 150 m) excluding GST				

- Note:**
1. The Pilot Hole drilling should be carried out to target depth of 150 m plus 5 m in **bouldery rock formation**.
 2. Maximum of 203 mm dia hole will be drilled by DTH rig attached with ODEX System down to 40 m/ 50 m and thereafter 165 mm dia hole will be drilled down to the depth of 155 m with ODEX system. This will be subject to the variations depending upon the formation encountered. The well assembly of 152/100 mm size can be lowered to the desired depth as per actual bore hole condition. Drilling method can be changed to normal DTH method when bed rock is encountered and payment will be made on actual basis of length of casing pipe lowered, meterage of ODEX drilling and meterage of DTH drilling carried out.
 3. The formation likely to be encountered during drilling operation is bouldery, clay, silt & sandstone.
 4. **No payment shall be made if well is abandoned without lowering assembly upto the recommended depth citing formation problem.**
 5. No payment shall be made if any well is abandoned due to fault of contractor or due to machinery, bore hole fishing, etc citing formation problem except under extraordinary situations like interference/ objection by the Local Government Bodies or public agitation against drilling leading to law and order problems, etc.
 6. Payment for gravel packing shall be in terms of meterage height measured from the bottom of reamed depth. Also gravel in terms of volume consumed should be cross checked with theoretical volume of gravel packing to ensure there is no bridging during gravel packing. The actual volume of gravel used and theoretical annular volume of gravel should be provided for each wells.
 7. Water samples shall be collected as per the standard procedures at the closure of well development as per the standard procedures. Water samples will be collected in 3 pre-treated HDPE containers (1 no. of 1 litre capacity container for basic parameters, 2 nos. of 500 ml capacity containers for heavy metals). The samples for arsenic parameter should be acidified with ultrapure HCl (1:1 HCl) and the samples for other heavy/ trace metals should be acidified with ultrapure HNO₃ (1:1 HNO₃).
 8. All the collected water samples shall be submitted to CGWB and water samples should be properly sealed and labelled with the relevant details like location (including Lat and Long), well number and type, date and time of sampling, stage of pumping test/ well development, details of acidification, water temperature at the time of sample collection, etc.
 9. The water samples collected during the last stage of well development in case of Piezometer shall be analysed for basic parameters and heavy metals as per BOQ by the contractor through NABL Lab and one more set of these water samples shall be submitted to CGWB for validation along with original report of NABL Lab.
 10. Well development will be treated as completed only when water is clear and free of suspended particles during pumping. Well will be treated as completed only after construction of well as per the recommended well assembly and after conducting the well development and all other items mentioned in the BOQ and submission of BDRs duly validated by CGWB. Payment for the well shall be made only when the well is constructed as per the BOQ specification.
 11. Litholog collected (minimum 250 g) as per BOQ should be properly packed in good quality packing cover and should be tagged with details of sample No, site name, well type, depth range of litholog, etc and should be submitted to CGWB Regional office along with drill time log and logging details including logging graph.

12. If additional quantity of any item is needed as per technical requirement at site, the same shall be decided by CGWB, ER in concurrence with the PMC, CGWB, CHQ.

13. CGWB, CHQ / CGWB, ER will not be responsible for any site related issues like rig / manpower, transportation, local disputes etc. at any point of time.

WB PZ BOQ 4

BOQ Template for Piezometer construction of West Bengal (Hard Rock 150 m)						
Piezometers in Hard Rock				Shallow (Hard Rock)		
State(s) West Bengal (AAP 2022-23)						
Number of Piezometers				1	number	
Depth of pilot hole				150	meter	
Average depth of well construction				150	meter	
Diameter of housing pipe (ID)				178	mm	
Length of housing pipe (should be left blank if the diameter of housing and intake pipe is same)				40	meter	
Diameter of intake pipe				0	mm	
Average Length of intake pipe (screen)				0	meter	
Average Length of intake pipe (screen), Type of screen Stainless steel of SS304 grade				0		
Slot opening				0	mm	
Average Development of Piezometer by air compressor				5	hours	
Collection of water samples per site				2	number	
Number of samples per well to be tested for Basic Parameters				1	number	
Number of samples per well to be tested for Heavy Metals				1	number	
S. No.	Item of work	Unit	Rate/ Unit Quantity (Excluding GST)	Total Meterage/Total no.	Total Amt. (Excluding GST)	

1	Drilling of over burden using rock roller/ drag bit/Button bit to accommodate casing pipe of 178 mm (7") dia up to bed rock including formation sample collection at every 3 m and change in formation, preparation and submission of litholog along with video recordings	meter		40	
1.1	Drilling by DTH method using appropriate sizes of button bits so as to reach targeted depth with diameter of hole not less than 165 mm at 100 m depth and final diameter not less than 152 mm at bottom of holes/150 m depth including sample collection and preparation of litholog	meter		110	
2	Caliper logging to decipher the depth and width of fracture zones, submission of report including logging graph, interpretation of graph, generation of composite log along with video recording	job		1	
3	Supply and installation of ERW casing pipe conforming to latest version of IS: 4270-2001 of diameter and thickness given below				
3.1	178 mm (7") Nominal Bore, thickness of casing pipe: 7.1 mm	meter		40	

4	Development by Air Compressor of adequate capacity for minimum 5 hours, over pumping and by other means till discharge water is clear and free of sand including collection of two water samples from PZ well adopting standard procedure in 1 litre HDPE bottle, along with video recordings of compressor hour meter, discharge etc.	job		1	
5	Chemical analysis of water samples for 15 parameters (pH, EC, TH, TDS, Ca, Mg, Na, K, CO ₃ , HCO ₃ , SO ₄ , NO ₃ , Cl, F & Fe) in NABL accredited lab	job		1	
6	Chemical analysis of water samples for Heavy Metals (As, U) in NABL accredited labs and submission of report from NABL accredited lab	job		1	
7	Construction of cement concrete platform of dimension 0.70 X 0.70 X 0.60 m (0.30 m above ground level) using concrete mix of 1:2:4 around the around the Piezometer well welded with minimum 6 Nos of anchoring plate as per drawing	job		1	
8	Supply and fitting of well cap as per drawing with Allen Keys. MS Plate size 5 mm embossed & welded with permanent marking of "CGWB PZ" should be carved with welding on outer surface of casing pipe.	job		1	

9	Supply and installation of protection box made of 3 mm GI sheet of Size: 550 mm X 450 mm X 530 mm along with Brass lock (7 lever hardened of reputed brand) and three keys for each lock as per drawing	job		1	
10	Supply and installation of Display Board as per drawing	job		1	
11	Preparation and submission of basic data report per site in triplicate along with data sheets, analysis sheet, chemical analysis report from NABL lab, site location map and approachability with landmarks, photographs and videos of activities of drilling, assembly lowering, gravel measurement and gravel packing, well development using compressor and well water discharge, water sample collection, well discharge with discharge measurement, well site with display board, well cap, protection box for each site, etc. The soft copy as well as hard copy should be submitted. Summary of Piezometer details in xls format (as per proforma given by CGWB) including details of dia and depth of assembly pipe, screen pipe, static water level, gravel packing depth and thickness, Litholog etc. should be also submitted.	job		1	
	Total (excluding GST)				
	Average rate per Piezometer (Hard Rock 150 m) excluding GST				

Note:	1. The Pilot Hole drilling should be carried out to target depth of 150 m in bed rock .				
	2. No payment shall be made if well is abandoned without lowering surface casing upto the depth of bed rock/recommended depth citing formation problem.				
	3. No payment shall be made if any well is abandoned due to fault of contractor or due to machinery, bore hole fishing, etc citing formation problem except under extraordinary situations like interference/objection by the Local Government Bodies or public agitation against drilling leading to law and order problems, etc.				
	4. Water samples shall be collected as per the standard procedures at the closure of well development as per the standard procedures. Water samples will be collected in 3 pre-treated HDPE containers (1 no. of 1 litre capacity container for basic parameters, 2 nos. of 500 ml capacity containers for heavy metals). The samples for arsenic parameter should be acidified with ultrapure HCl (1:1 HCl) and the samples for other heavy/ trace metals should be acidified with ultrapure HNO ₃ (1:1 HNO ₃).				
	5 All the collected water samples shall be submitted to CGWB and water samples should be properly sealed and labelled with the relevant details like location (including Lat and Long), well number and type, date and time of sampling, stage of pumping test/ well development, details of acidification, water temperature at the time of sample collection, etc.				
	6 The water samples collected at the last stage of well development in case of Piezometer shall be analysed for basic parameters and heavy metals as per BOQ by the contractor through NABL Lab and one more set of these water samples shall be submitted to CGWB for validation along with original report of NABL Lab.				
	7. Well development will be treated as completed only when water is clear and free of suspended particles during pumping. Well will be treated as completed only after construction of well as per the recommended well assembly and after conducting the well development, pumping test and all other items mentioned in the BOQ and submission of BDRs duly validated by CGWB . Payment for the well shall be made only when the well is constructed as per the BOQ specification.				
	7. Litholog collected (minimum 250 g) as per BOQ should be properly packed in good quality packing cover and should be tagged with details of sample No, site name, well type, depth range of litholog, etc and should be submitted to CGWB Regional office along with drill time log and logging details including logging graph.				
	8. If additional quantity of any item is needed as per technical requirement at site, the same shall be decided by CGWB, ER in concurrence with the PMC, CGWB, CHQ.				
	9. CGWB, CHQ / CGWB, ER will not be responsible for any site related issues like rig / manpower, transportation, local disputes etc. at any point of time.				

EXPLANATORY NOTE FOR BOQ's (Soft Rock)

PRICE: This is a works contract involving construction of wells as mentioned in the tender. The price is to be paid for supply and execution of work of various items or for materials

Explanatory notes in respect of each item of BOQ are given below. The BOQ shall be read in conjunction with explanatory notes of the concerned item along with Tender documents. The price shall be quoted accordingly.

1. **Drilling of Pilot Hole** in BOQ includes

- i. Site preparation and erection of tent with furniture to facilitate CGWB representative to discharge his duties at each site.
- ii. Drilling with 216mm(8 ½") RR/DRAG Bit to the targeted depth of 300m plus 5m, using bentonite mud.
- iii. Formation Sample collection (minimum 500g) during drilling for every 3m interval depth and also at the instance of change of formation during drilling (depth of change in formation to be recorded) and properly washed, dried and packed in polythene bags and labeled with date/ depth/ location
- iv. Maintain a drill time log for every 3 m and at depth where there is a change in formation(i.e. within 3m interval of litho log sample collection)
- v. Preparation and submission of litholog along with drill time log.
- vi. Any other activities pertaining to above drilling activity & recording of important information during drilling

2. **Reaming of Hole in BOQ** : includes

- i. Drilling with suitable minimum 381 mm (15")size RR/DRAG Bit to accommodate 150 mm (NB)casing pipes to the targeted depth(assembly depth plus 5m),as decided by CGWB site representative. Payment shall be restricted to actual depth of drilling or assembly depth plus 5m whichever is less.
- ii. CGWB site representative will decide the depth of assembly to be lowered.
- iii. If required, Formation Sample collection (minimum 500g) during drilling for every 3m interval depth and also at the instance of change of formation during drilling (depth of change in formation to be recorded) and properly washed, dried and packed in polythene bags and labeled with date/ depth/ location.
- iv. Maintain a drill time log for every 3 m and at depth where there is a change in formation (i.e. within 3m interval of litho log sample collection).
- v. Preparation and submission of litholog along with drill time log.
- vi. Any other activities pertaining to above drilling activity & recording of important information during drilling

3. **Logging in BOQ:** includes

- (i) electrical logging using 406mm and 1626mm (16" & 64") resistivity probe, SP and natural gamma logging up to the targeted depth (up to bottom depth of pilot hole) .
- (ii) In case the logging could not be completed to desired depth in 8 ½" pilot hole after repeated attempts, logging in larger dia hole may be allowed by site hydrogeologist and no additional payment will be made for enlargement of hole for logging purpose and for additional attempts of logging.
- (iii) Preparation of composite log and submission of report along with data and analysis as Proforma given in section VIII
- (iv) Report should also include zonewise water Quality. The logging should decipher all the zones having at least one meter thickness.
- (v) Graph sheet, analysis etc. should be provided
- (vi) Any other related activities.

4. **Enlargement of Hole in BOQ:** includes
 - i. Enlargement of hole with suitable minimum 508mm (20") size RR Bit to accommodate 250 mm (NB) (10") well assembly pipes to the targeted depth(assembly depth plus 5m),as decided by CGWB site representative in EW
 - ii. CGWB site representative will decide the depth of assembly to be lowered.
 - iii. Any other related activities

5. **Supply and Installation of ERW Casing Pipes in BOQ:** Includes
 - i. Supply of 250mm (NB) (10")dia with thickness of 7.1mm(for EW) and 150mm(NB) (6")dia(for OW) with thickness of 5.4mm ERW casing pipe confirming to latest version of IS: 4270-2001 with pipe ends edges beveled, and the same should be inspected by Executive Engineer or the CGWB representative and accepted by him.
 - ii. Lowering and Installation of the casing pipe including welding of pipes in the well
 - iii. CGWB site representative will decide the assembly size and the depth to be lowered.
 - iv. Any other related activities requiredfor supply and installation of casing pipe.

6. **Supply and Installation of LCG V-wire Screen in BOQ:** includes
 - i. Supply and installation of 250mm (NB) (10")with thickness of 10 mm (for EW)and 150mm(NB) (6")(for OW)with thickness of 7.0 mm, LCG V-Wire screen with slot opening 1.0mm confirming to latest Version of IS:8110-200.
 - ii. The material should be inspected by and approved by Executive Engineer or CGWB representative before lowering.
 - iii. The length of slot and position of slot in the well assembly will be decided by CGWB representative.
 - iv. Any other related activities requiredfor supply and installation of LCG pipe.

7. **Supply and Shrouding by Pea Gravel in BOQ includes**
 - i. Supply and shrouding with pea gravel confirming to latest version of IS: 4097-1967 The Particle size range 2.0 mm to 3.35 mm for 1.0 mm slot opening.
 - ii. The gravel before shrouding should be inspected and approved by the Executive Engineer or CGWB representative.
 - iii. The depth up to which gravel shrouding is to be carried out will be decided by CGWB representative. The gravel shrouding shall be carried out after thinning the mud fluid using reverse fluid flow (back washing method).
 - iv. Sufficient care should be taken so that gravel packing is proper and there is no bridging during gravel packing. If necessary, in case of bridging of gravel, air compressor of appropriate capacity should be used for proper gravel shrouding as per instruction of employer's site representative for which no additional cost will be paid. As a cross check, the theoretical annular volume of gravel packing and volume of actual gravel consumed shall be compared.
 - v. Any other related activities

8. **Cement Sealing in BOQ includes**
 - i. Before cement sealing, sounding should be carried out to ascertain correct depth of gravel shrouding.
 - ii. Before cement sealing 1 m thick clay shall be provided above gravel.
 - iii. Supply and cement sealing using 53 grade cement of 5m thickness.
 - iv. Adequate rest(minimum 10 hrs) shall be provided after cement sealing.
 - v. Any other related activities.

9. **Supplying and filling up of borehole/ Annular space with clay in BOQ:** includes

- i. Supply and filling up of bore hole/annular space between casing pipe and bore hole wall with clay balls as per the instruction of CGWB representative.
- ii. Any other related activities

10. Development by Air Compressor in BOQ: includes

- (i) Development of well by air compressor of adequate capacity, over pumping with VT/Submersible pump and/ or any other means till the water is clear and free from sand.
- (ii) Each slotted zones should be developed till discharge water becomes clear as decided by the CGWB representative.
- (iii) The two water samples (one for basic parameters analysis & one for heavy metals) shall be collected from OW following standard procedure in Polypropylene bottle(1 litre capacity) as per instruction CGWB representative.
- (iv) The water discharge from well during well development should be measured using V notch and recorded in the site register.

11. Chemical Analysis in BOQ: includes

- i. Supply of Polypropylene bottle(1 litre capacity) by the contractor
- ii. Collection of water samples in 1 litre Polypropylene bottles for analysis of basic parameters following standard procedure as per direction of CGWB site representative.
- iii. Transportation and chemical analysis of water sample in NABL accredited Lab
- iv. Each water sample shall be analysed for 15 parameters pH, EC, Total Hardness, Ca, Mg, Na,K,CO₃, HCO₃, SO₄, NO₃,Cl, F, PO₄ & Si
- v. Collection of water samples has to be carried out in all wells except dry wells
- vi. Submission of chemical analysis report (soft and hard copies) duly validated by employer
- vii. Any other activities pertaining to collection of water samples and water sample analysis

12. Chemical Analysis in BOQ: includes

- i. Supply of Polypropylene bottle(1 litre capacity) by the contractor
- ii. Collection of water samples in 1 litre Polypropylene bottles for analysis of heavy metals following standard procedure as per direction of CGWB site representative.
- iii. Transportation and chemical analysis of water sample in NABL accredited Lab
- iv. Each water sample shall be analysed for heavy metals Fe, Cu, Pb, Cd, Zn, Cr, Co and Ni
- v. Submission of chemical analysis report (soft and hard copies) duly validated by employer
- vi. Any other activities pertaining to collection of water samples and water sample analysis

13. Supply and Fitting of Well Cap in BOQ: includes :

- i. Supply and fitting of well cap in all wells as per specifications given in tender.
- ii. CGWB marking on pipes using welding.
- iii. Any other related activities

14. Construction of Cement concrete platform in BOQ: includes

- i. Construction of cement concrete platform measuring 0.70 X 0.70 X 0.60 m (0.30 m above ground level) using concrete mix of 1:2:4 around the housing pipe welded with anchoring plate 6 Nos as per drawing given in the section IX
 - ii. The area surrounding the well site has to be leveled, pits to be filled and the area to be restored to the original condition i.e. as before start of drilling operation and ensure all safety precautions.
 - iii. Any other activities required for well completion as mentioned in the section VII-Work requirements
15. **Supply and installation of protection box in BOQ:** includes
- i. Supply and installation of protection box as per specification given in tender document
 - ii. Supply of Brass lock (7 lever) with all common keys (One Key for multiple locks) preferably Make: Godrej/Harrison/Link with three individual keys for each well
 - iii. The above work is to be carried out in all wells
 - iv. Any other related activities
16. **Supply and Installation of Display board in BOQ:** includes
- i. Supply of Display Board as per Drawing: Display Board should be coated (minimum two coating) with antirust paint
 - ii. Installation of Display Board using concrete as per drawing. Each site will have one display board.
 - iii. Incorporation of details of well in the Display Board. In case of OW, details pertaining OW should be also incorporated in addition to Piezometer details as per the proforma given by the Employer's site representative. Any other information as desired by employer should also be incorporated in the Display Board.
 - iv. Any other activities related to supply and installation of Display Board.
17. **Preperation and Submission of BDR in BOQ:** includes
- i. Basic Data Report (BDR) along with data, graph sheet, analysis etc. as per proforma given in section VIII should be prepared for each site separately and submitted both in soft and hard copies. In site having both EW & OW the details (Litholog, static water level, drill time log etc.) pertaining to both EW & OW should be incorporated in the BDR.
 - ii. In case of site having more than one well, one BDR only be prepared but all the wells detail should be incorporated in that BDR.
 - iii. BDR Data and analysis should be duly validated and accepted by the Regional Director
 - iv. Any other activities

Note:

- 3. No payment will be made for the shiting of the rig unit and goods required for the construction of the wells as it is deemed to be included in the items cost of BOQ.
- 4. Wherever logging is conducted, the pilot hole depth in EW will be restricted to logging depth in case of variation between pilot hole depth and logging depth.

EXPLANATORY NOTE FOR BOQ's (Hard Rock)

PRICE: This is a works contract involving construction of wells and carrying out pumping test as mentioned in the tender. The price is to be paid for supply and execution of work of various items or for materials

Explanatory notes in respect of each item of BOQ are given below. The BOQ shall be read in conjunction with explanatory notes of the concerned item along with Tender documents. The price shall be quoted accordingly.

1. Drilling of Overburden in BOQ: includes

- i. Drilling with suitable size RR/DRAG/BUTTON Bit to accommodate suitable casing pipes as per BOQ to a depth till hard rock formation is encountered as decided by CGWB site representative
- ii. Formation Sample collection (minimum 250g) during drilling for every 3m interval depth
- iii. Recording of water discharge using V-notch on encountering formation with significant discharge. Depth at which formation with discharge encountered should be recorded,
- iv. Preparation and submission of litholog
- v. Providing tent along with table chairs etc. for employer site representative for discharging his duties smoothly
- vi. Any other activities pertaining to above drilling activity

2. Supply and Installation of ERW casing pipe of BOQ: includes

- i. Supply of suitable ERW casing pipe as per BOQ confirming to latest version of IS: 4270-2001 with thickness 5.4mm and the same should be inspected by the CGWB officer and accepted by him
- ii. Installation of 175mm casing pipe in the overburden
- iii. CGWB site representative will decide the length of casing pipe to be lowered
- iv. Any other activities pertaining to above activity

3. Drilling by DTH method in BOQ: includes

- i. Drilling by DTH method using appropriate sizes of button bit so as to reach targeted depth with diameter of hole not less than 165mm up to 100m depth and final diameter not less than 152mm up to targeted depth (200m).
- ii. Formation Sample collection (minimum 250g) during drilling for every 3m interval depth or in the event of change in formation
- iii. Recording of water discharge using 90 degree V-notch (to be supplied by contractor) on encountering formation with significant discharge. Depth at which formation with discharge encountered should also be recorded
- iv. Preparation of litholog
- v. Above drilling by DTH had to be carried out in all 200m (EW & OWs)/ PZ of Package (Hard Rock)
- vi. Any other activities pertaining to above drilling activity

4. Collection of Water Sample in BOQ: includes

- i. Collection of water sample in 1 litre HDPE bottle during drilling i.e. on encountering formation with significant discharge, pumping tests, following standard procedure as per direction of CGWB site representative.
- ii. Supply of HDPE bottle(1 litre capacity) by the contractor
- iii. Transportation and chemical analysis of water sample in NABL accredited Lab
- iv. Each water sample shall be analysed for 15 parameters pH, EC, Total Hardness, TDS, Ca, Mg, Na,K,Co₃, HCO₃, SO₄, NO₃,Cl, F, Fe
- v. Collection of water samples has to be carried out in all wells except dry wells
- vi. Submission of chemical analysis report (soft and hard copies) duly validated by employer
- vii. Any other activities pertaining to collection of water samples and water sample analysis

5. **Supply and fitting of Well Cap in BOQ:** includes :
 - i) Supply and fitting of well cap in all wells as per drawing,
 - ii) Any other activities pertaining to supply and fitting of well cap

6. **Construction of Cement Concrete Platform in BOQ:** includes :
 - i. Construction of cement concrete platform measuring 0.70 X 0.70 X 0.60 m (0.30 m above ground level) using concrete mix of 1:2:4 around the housing pipe welded with anchoring plate 6 Nos as per drawing given in the tender document.
 - ii. Restoration of ground to previous natural condition

7. **Supply and Installation of Protection box in BOQ:** includes
 - i. Supply and installation of protection box as per specification given in tender document
 - ii. Supply of Brass lock (7 lever) with all common keys (One Key for multiple locks) preferably Make: Godrej/Harrison/Link with three individual keys for each well
 - iii. Any other activities pertaining to installation of protection box

8. **Preparation and submission of BDR in BOQ:** includes
 - i. Basic Data Report (BDR) along with data, graph sheet, analysis etc. should be prepared for each site separately and submitted both in soft and hard copies. In site having both EW & OW/ PZ the details (Litholog, static water level, depths at which discharge encountered and respective discharge measured using V-notch) pertaining to both EW & OW/ PZ should be incorporated in the BDR.
 - ii. In case of site having more than one well, one BDR only be prepared but all the wells detail should be incorporated in that BDR.
 - iii. BDR Data and analysis should be duly validated and accepted by the Regional Director.

9. **PYT in BOQ:** includes
 - i. Supply of Infrastructure required for Preliminary Yield test education pipe, airline, steel tape of appropriate length for measuring the depth of well or water level recorder etc.
 - ii. Lowering of education pipe and airline as per procedure mentioned in the tender document.
 - iii. Conducting PYT as per procedure/methodology mentioned in the tender document
 - iv. Measurement of water level at intervals as per procedure given in the pumping
 - v. Installation of 20mm pipe for water level measurement
 - vi. Recording of data and analysis of PYT Data generated as per proforma given in tender document
 - vii. Arrangement for draining of discharge during pumping test to nearest drain safely through channels of pipes without creating hindrance to public
 - viii. The PYT shall be carried out as decided by CGWB's site representative.
 - ix. Submission of Data and analysis (Soft and hard copy) report duly validated by employer

10. **Slug test in BOQ:** includes
 - i. Supply of Infrastructure required for slug test including arrangement of water needed for slug test, water level recorder etc.
 - ii. Conducting Slug test as per the procedure given in the tender.
 - iii. Measurement of static water level and also measurement of water level at closely spaced interval I during the test
 - iv. The slug test shall be carried out in low yielding borewell/tubewells as decided by CGWB's site representative.

11. **Supply and installation of Display Board in BOQ:** includes

- i Supply of Display Board as per Drawing: Display Board should be coated (minimum two coating) with antirust paint
- ii Installation of Display Board using concrete as per drawing. Each site will have one display board.
- iii Incorporation of details of well in the Display Board. In case of OW, details pertaining OW should be also incorporated in addition to EW details as per the proforma given by the Employer's site representative. Any other information as desired by employer should also be incorporated in the Display Board.
- iv Any other activities related to supply and installation of Display Board.

Note:

No payment will be made for mobilization of rig unit and goods required for construction of wells as it is deemed to be included in the item's cost of BOQ.

PART B

Package 6- DWLR BOQ					
PRICE SCHEDULE					
(This BOQ template must not be modified/replaced by the bidder and the same should be uploaded after filling the relevent columns, else the bidder is liable to be rejected for this tender. Bidders are allowed to enter the Bidder Name and Values only)					
NUMBER #	TEXT #	NUMBER #	TEXT #	NUMBER	NUMBER
Sl. No.	Item Description	Quantity	Units	Rate in Rs. P	TOTAL AMOUNT Without GST in Rs. P
0	Supply, Installation,testingandCommissioning of DWLRs and telemetry, establishment of Data Acquisition system & its maintenance for Real Time Ground Water Level monitoring and supply of Ground water level, ground water temperature from site and receipt of data at concerned Regional Office Data Centre (RODC) and subsequently to National Data Center of CGWB at Faidabad in a desired format from 810 Piezometers wells in the states of UP, Bihar, Jharkhand, West Bengal, Odisha through telemetry systems with 05 years warranty and 02 years AMC. (RODC at CGWB, ER, Kolkata, West Bengal)				

1.1	<p>Without Quality Probe: Supply, Installation, testing, commissioning, training for Digital Water Level Recorders (DWLRs) with non-vented hydrostatic pressure type sensor and barometric pressure correction and, with temperature sensor for individual station with desired measurement range and standard sensor cable along with junction boxes and 5 meter signal cable, to be installed at depth as per list and necessary accessories with battery operated data logger and telemetry System based on GSM & GPRS as per the technical specifications (As the tender document) to be installed at designated locations as per list in tender document. This includes 05 years comprehensive warranty and O&M which also includes replacement of batteries as & when required, replacement of spares/parts/equipments/consumables, periodic inspections, repairing/service charges, the cost of Communication using GSM & GPRS SIM and other related charges. Minimum One Service Engineer shall be placed at concerned RODC for Operation of DWLR system with Telemetry. This is a Continuous activity for five years after successful commissioning and final acceptance certificate of DWLR. This also include Training of the purchaser's personnel by the supplier on assembly, startup, operation, maintenance and/or repair of DWLR with telemetry and relevant software and supplied goods. Two types of trainings are to be organised. (i) Onsite training to be organised in each State where DWLRs are to be installed. One onsite trainings for each State (ii) Training at concerned Regional Office Data Center(RODC) of CGWB. Two trainings at concerned RODC. Course topics will include sensor calibration, data logger configuration, data downloading, data retrieval, collection, Trouble shooting, processing maintenance requirements and procedure for equipment configuration, installation, site testing and commissioning including training kit containing course material in soft and hard copies as per technical specification.</p> <p>Note: For Validation of data, Physical</p>	790	Nos		
-----	--	-----	-----	--	--

	measurement shall be cross checked with the data generated from DWLR.				
1.2	<p><u>With Quality Probe:</u> <u>With Quality Probe:</u>Digital Water Level Recorders (DWLRs) with non-vented hydrostatic pressure type sensor and barometric pressure correction and, with temperature sensor and with electrical conductivity for individual station with desired measurement range and standard sensor cable along with junction boxes and 5 meter signal cable, to be installed at depth as per list and necessary accessories with battery operated data logger and telemetry System based on GSM & GPRS as per the technical specifications (As per the tender document) to be installed at designated locations as per list in tender document.</p> <p>This includes 05 years comprehensive warranty and O&M which also includes replacement of batteries as & when required, replacement of spares/parts/equipments/consumables, periodic inspections, repairing/service charges, the cost of Communication using GSM & GPRS SIM and other related charges. Minimum One Service Engineer shall be placed at concerned RODC for Operation of DWLR system with Telemetry. This is a Continuous activity for five years after successful commissioning and final acceptance certificate of DWLR.</p> <p>This also include Training of the purchaser's personnel by the supplier on assembly, startup, operation, maintenance and/or repair of DWLR with telemetry and</p>	20	Nos		

	<p>relevant software and supplied goods. Two types of trainings are to be organised. (i) Onsite training to be organised in each State where DWLRs are to be installed. One onsite trainings for each State (ii) Training at concerned Regional Office Data Center(RODC) of CGWB. Two trainings at concerned RODC. Course topics will include sensor calibration, data logger configuration, data downloading, data retrieval, collection, Trouble shooting, processing maintenance requirements and procedure for equipment configuration, installation, site testing and commissioning including training kit containing course material in soft and hard copies as per technical specification.</p> <p>Note: For Validation of data, Physical measurement shall be cross checked with the data generated from DWLR.</p>				
2	Server of reputed brand with accessories, work station and 3 KVA online UPS as per tender document. (One set up to be created at the concerned RODC and one at NDC Faridabad)	2.0	Nos		
3	IT hardware which includes required static, IP, router, switch, firewall system & A3 size color printer.	2.0	Nos		
4	42" LED Display system as per technical specifications.	2.0	Nos		
5	High Speed Interned Connection (minimum 8 mbps upload and 8 mbps download) for five years.	2.0	Nos		
6	GSM & GPRS data receiving system with all ancillary equipment as per technical specifications.	2.0	Nos		
8	Installation, Testing and Commissioning of Server along with monitor, Computer node (Workstation) and 3 KVA online UPS as per technical specifications	2.0	Nos		

9	Installation, testing & commissioning of IT hardware which includes required static IP, router, switch, firewall system & A3 Size Color Printer.	2.0	Nos		
10	Installation, testing & commissioning of 42" LED Display system as per technical specifications.	2.0	Nos		
11	Installation, testing & commissioning & charges of High Speed Internet Connection (minimum 8 mpbs upload and 8 mbps download) for 5 years.	2.0	Nos		
12	Installation, testing & commissioning GSM & GPRS data receiving system with all ancillary equipment as per technical specifications.	2.0	Nos		
14	Comprehensive AMC for DWLR with telemetry System along with all accessories, installed at designated locations and Data Centerequipments as specified in schedule of requirement after 5 years warranty period. This includes the replacement of batteries as and when required, replacement of spares/parts/equipments/consumables, periodic inspections, repairing/service charges, the cost of communication using GSM & GPRS, SIM and High Speed Internet charges and other related charges. Note: Continuous activity for Two year after five years comprehensiveO&M and warranty period.	24	Months		
Total in Figures					

SECTION-VII
TENTATIVE LIST OF LOCATIONS

SECTION-VII

Tentative
list for
Constructi

TENTATIVE LIST OF LOCATIONS

on of Piezometer Wells and Installation of DWLR and Telemetry through Out-sourcing in Bihar, Jharkhand, Uttar Pradesh, Odisha and West Bengal.

BR PZ BOQ 1 and BR PZ BOQ 2									
S. No.	District	Assessment unit	Name of Village/ Location	Latitude	Longitude	Category	Proposed Depth	Tentative depth for DWLR installation (m)	BOQ Name
1	Araria	Forbesganj	Forbesganj	26.3025	87.2648	Safe	100m	25	BR PZ BOQ 1
2	Araria	Araria	Araria	26.1349	87.4625	Safe	100m	25	BR PZ BOQ 1
3	Aurangabad	Barun	Barun	24.8705	84.2149	Safe	100m	30	BR PZ BOQ 1
4	Aurangabad	Deo	Deo	24.6578	84.4371	Safe	100m	40	BR PZ BOQ 1
5	Aurangabad	Rafiganj	Rafiganj	24.8171	84.6338	Safe	100m	40	BR PZ BOQ 1
6	Banka	Banka	Banka	24.8865	86.9203	Safe	100m	55	BR PZ BOQ 2
7	Begusarai	Barauni	Barauni	25.4702	85.9694	Safe	100m	30	BR PZ BOQ 1
8	Begusarai	Navkothi	Pahsara	25.5504	86.1657	Semi-critical	100m	30	BR PZ BOQ 1
9	Begusarai	Bhagawanpur	Chakpur	25.5591	85.9659	Semi-critical	100m	35	BR PZ BOQ 1
10	Bhagalpur	Kahalgaoon	Kahalgaoon	25.2625	87.2355	Safe	100m	35	BR PZ BOQ 1
11	Bhagalpur	Jagdishpur	Bhagalpur	25.4664	84.419	Safe	100m	25	BR PZ BOQ 1
12	Bhojpur	Bihiya	Bihiya	25.5579	84.4484	Semi-critical	100m	30	BR PZ BOQ 1
13	Buxar	Buxar	Buxar	25.5652	83.9716	Safe	100m	30	BR PZ BOQ 1
14	Darbhanga	Darbhanga	Darbhanga	26.1508	85.8986	Safe	100m	40	BR PZ BOQ 1

15	Darbhanga	Hayaghat	Hayaghat	26.0189	85.8787	Safe	100m	30	BR PZ BOQ 1
16	East Champara n	Raxaul	Raxaul	26.9819	84.8518	Safe	100m	25	BR PZ BOQ 1
17	East Champara n	Motihari	Motihari	26.6519	84.9219	Safe	100m	30	BR PZ BOQ 1
18	East Champara n	Ghorasahan	BaghahiBhelw a	26.7756	85.0987	Safe	100m	25	BR PZ BOQ 1
19	Gaya	Barachatty	Sobh	24.512	84.971	Safe	100m	55	BR PZ BOQ 1
20	Gaya	Gaya Sadar	Dhansir	24.7642	84.9519	Semi- critical	100m	60	BR PZ BOQ 2
21	Gaya	Manpur	Budhgere	24.7969	85.071	Over- exploite d	100m	50	BR PZ BOQ 1
22	Gaya	Belaganj	Silaunja	24.9463	84.9796	Over- exploite d	100m	50	BR PZ BOQ 1
23	Gaya	Imamganj	Raniganj	24.437	84.5919	Over- exploite d	100m	50	BR PZ BOQ 2
24	Gopalganj	Gopalganj	Gopalganj	26.4625	84.4426	Safe	100m	25	BR PZ BOQ 1
25	Jamui	Jamui	Jamui	24.921	86.225	Safe	100m	60	BR PZ BOQ 1
26	Jamui	Chakai	Madhopur	24.5742	86.508	Safe	100m	55	BR PZ BOQ 2
27	Jehanabad	Kako	KajiSarai	25.1682	85.0717	Semi- critical	100m	40	BR PZ BOQ 1
28	Jehanabad	RatniFaridpu r	Shakurabad	25.1526	84.9027	Over- exploite d	100m	30	BR PZ BOQ 1
29	Jehanabad	Ghoshi	Dariyapur	25.1225	85.116	Critical	100m	30	BR PZ BOQ 1
30	Jehanabad	Hulasgunj	Murgaon	25.1532	85.1659	Critical	100m	30	BR PZ BOQ 1
31	Jehanabad	Jehanabad	Nauru	25.1768	84.9866	Critical	100m	40	BR PZ BOQ 1
32	Kaimur	Bhabhua	Bhabhua	25.0397	83.6066	Safe	100m	35	BR PZ BOQ 1
33	Kaimur	Adhaura	Adhaura	24.6991	83.6123	Safe	100m	45	BR PZ BOQ 2

34	Katihar	Katihar	Katihar	25.5383	87.5756	Safe	100m	25	BR PZ BOQ 1
35	Khagaria	Khagaria	Khagaria	25.5042	86.4705	Safe	100m	30	BR PZ BOQ 1
36	Kishanganj	Kishanganj	Kishanganj	26.1068	87.9471	Safe	100m	25	BR PZ BOQ 1
37	Lakhisarai	Lakhisarai	Lakhisarai	25.1718	86.096	Safe	100m	35	BR PZ BOQ 1
38	Madhepura	Murliganj	Murliganj	25.9019	86.9929	Safe	100m	25	BR PZ BOQ 1
39	Madhepura	Shankarpur	Shankarpur	26.0311	86.8687	Semi-critical	100m	25	BR PZ BOQ 1
40	Madhepura	UdaKishanganj	UdaKishanganj	25.6783	86.945	Semi-critical	100m	25	BR PZ BOQ 1
41	Madhubani	Pandaul	Pandaul	26.2512	86.074	Safe	100m	30	BR PZ BOQ 1
42	Madhubani	Jainagar	SilanathDulipatti	26.5614	86.1083	Safe	100m	30	BR PZ BOQ 1
43	Madhubani	Laukahi	Narhiya South	26.3626	86.5344	Safe	100m	30	BR PZ BOQ 1
44	Munger	MungerSadar	MungerSadar	25.3725	86.4714	Safe	100m	45	BR PZ BOQ 1
45	Munger	Jamalpur	Jamalpur	25.3074	86.4888	Safe	100m	40	BR PZ BOQ 2
46	Muzaffarpur	Sahebganj	Sahebganj	26.2973	84.9264	Safe	100m	25	BR PZ BOQ 1
47	Muzaffarpur	Sakra	Bariyarpur	25.9383	85.4714	Over-exploited	100m	40	BR PZ BOQ 1
48	Muzaffarpur	Mushahari	Muzaffarpur	26.1179	85.3816	Over-exploited	100m	30	BR PZ BOQ 1
49	Nalanda	Biharsarif	Biharsarif	25.1868	85.5257	Safe	100m	30	BR PZ BOQ 1
50	Nalanda	Giriyak	Pawapuri	25.089	85.5439	Over-exploited	100m	30	BR PZ BOQ 1
51	Nawada	Nawada	Nawada	24.8805	85.542	Semi-critical	100m	60	BR PZ BOQ 1
52	Nawada	Meskaur	BijuBigha	24.7465	85.3855	Critical	100m	70	BR PZ BOQ 1
53	Patna	Belchhi	Saksohra East	25.0217	85.3772	Semi-critical	100m	30	BR PZ BOQ 1
54	Patna	Bihta	Bihta	25.5537	84.8704	Safe	100m	30	BR PZ BOQ 1

55	Patna	Fatuha	Fatuha	25.5088	85.3029	Safe	100m	35	BR PZ BOQ 1
56	Patna	Sampatchak	Gopalpur	25.5031	85.1465	Semi-critical	100m	35	BR PZ BOQ 1
57	Purnia	Dagaura	Belgachhi	25.8302	87.6768	Semi-critical	100m	35	BR PZ BOQ 1
58	Purnia	Purnia	Purnia	25.7768	87.4746	Safe	100m	30	BR PZ BOQ 1
59	Rohats	Bikramganj	Bikramganj	25.2224	84.2649	Safe	100m	70	BR PZ BOQ 1
60	Rohats	Sasaram	Sasaram	24.9601	84.0149	Safe	100m	30	BR PZ BOQ 1
61	Saharsa	Kahra	Kahra	25.8653	86.5725	Safe	100m	25	BR PZ BOQ 1
62	Samastipur	Ujiyarpur	Chandchaur	25.728	85.7964	Semi-critical	100m	40	BR PZ BOQ 1
63	Saran	Nagra	Aphaur	25.8818	84.7587	Semi-critical	100m	30	BR PZ BOQ 1
64	Saran	Chapra	Chapra	25.7673	84.7459	Safe	100m	30	BR PZ BOQ 1
65	Sheikhpura	Sheikhpura	Sheikhpura	25.1387	85.8398	Safe	100m	50	BR PZ BOQ 1
66	Sheohar	Sheohar	Sheohar	26.5136	85.2945	Safe	100m	30	BR PZ BOQ 1
67	Sitamarhi	Dumra	Sitamarhi	26.5926	85.4892	Safe	100m	30	BR PZ BOQ 1
68	Sitamarhi	Sonbarsa	Dostiya	26.7842	85.5621	Safe	100m	30	BR PZ BOQ 1
69	Siwan	Siwan	Siwan	26.2194	84.3584	Safe	100m	30	BR PZ BOQ 1
70	Siwan	Duraundha	Bagoura	26.0386	84.465	Semi-critical	100m	25	BR PZ BOQ 1
71	Supaul	Supaul	Supaul	26.1195	86.6013	Safe	100m	25	BR PZ BOQ 1
72	Vaishali	Hajipur	ChakBarauna	25.6857	85.3127	Semi-critical	100m	30	BR PZ BOQ 1
73	Vaishali	Patepur	Dabhaich	25.822	85.506	Critical	100m	30	BR PZ BOQ 1
74	West Champaran	Bettiah	Bettiah	26.7983	84.5077	Safe	100m	25	BR PZ BOQ 1

75	West Champaran	Ramnagar	Ramnagar	27.1635	84.3278	Safe	100m	35	BR PZ BOQ 1
----	----------------	----------	----------	---------	---------	------	------	----	-------------

JH PZ BOQ 1										
Sl. No	District	Assessment Unit	Category	Priority (Over-Exploited/Critical/Semical/Safe/Quality/Urban)	Location of Pz	Longitude	Latitude	Depth of Pz (in m)	Hard/soft Rock	tentative depth (in m) for installation of DWLRs
1	CHATRA	Simaria	Safe	Data Scarce Area	Simaria	84.93742	24.0605	100	Hard Rock	80
2	DEOGHAR	Sonarait hadhi	Semi-Critical	Semi-Critical	Sonarait hadhi	86.8998	24.359	100	Hard Rock	80
3	DEOGHAR	Sonarait hadhi	Semi-Critical	Data Scarce Area	Kolhariya	86.92019	24.3164	100	Hard Rock	80
4	DHANBAD	Baliapur	Critical	Critical/quality	Kharikabad	86.56938	23.6788	100	Hard Rock	80
5	DHANBAD	Baliapur	Critical	Data Scarce Area/quality	Pradhanakhunta	86.51623	23.7743	100	Hard Rock	80
6	DHANBAD	Topchanchi	OE	OE	Gomoh	86.1624	23.8707	100	Hard Rock	80
7	DHANBAD	Topchanchi	OE	Data Scarce Area	Manpur	86.25619	23.8632	100	Hard Rock	80
8	DUMKA	Jarmundi	Safe	Data Scarce Area	Jarmundi	87.0473	24.3948	100	Hard Rock	80
9	DUMKA	Ramgarh	Safe	Data Scarce Area	Ramgarh	87.2482	24.5639	100	Hard Rock	80
10	DUMKA	Saraiyahat	Safe	Data Scarce Area	Saraiyahat	87.0105	24.5802	100	Hard Rock	80
11	EAST SINGHBHUM	Boram	Safe	Data Scarce Area	Boram	86.2803	22.9568	100	Hard Rock	80
12	GARHWA	Bhandaria	Safe	Quality	Bargarh	83.785	23.635	100	Hard Rock	80
13	GARHWA	Bhawanathpur	Semi-	Semi-Critical/quality	Jhagrakha	83.5173	24.384	100	Hard Rock	80

			Critical							
14	GAR HWA	Bhawanathpur	Semi - Critical	Data Scarce Area/quality	Barwadih	83.6522	24.3938	100	Hard Rock	80
15	GAR HWA	Bhawanathpur	Semi - Critical	Data Scarce Area/quality	Pokhara	83.7144	24.4577	100	Hard Rock	80
16	GAR HWA	Dhurki	Safe	Quality	Dhurki	83.4513	24.143	100	Hard Rock	80
17	GIRID IH	Bagodar	Safe	Data Scarce Area	Bagodar	85.8309	24.0783	100	Hard Rock	80
18	GIRID IH	Dumri	Safe	Data Scarce Area	Dumri	86.0109	23.9939	100	Hard Rock	80
19	GIRID IH	Tisri	Safe	Data Scarce Area/quality	Tisri	86.0582	24.5697	100	Hard Rock	80
20	GUM LA	Basia	Safe	Data Scarce Area	Basia	84.824	22.8796	100	Hard Rock	80
21	GUM LA	Dumri	Safe	Data Scarce Area/quality	Dumri	84.1391	23.1643	100	Hard Rock	80
22	GUM LA	Raidih	Safe	Data Scarce Area	Raidih	84.4222	22.9302	100	Hard Rock	80
23	HAZ ARIB AGH	Daru	Semi - Critical	Semi-Critical	Mahesra	85.50424	24.0146	100	Hard Rock	80
24	JAMT ARA	Narayanpur	Safe	Data Scarce Area	Narayanpur	86.6147	24.0491	100	Hard Rock	80
25	JAMT ARA	Vidyasagar	Safe	Data Scarce Area	Vidyasagar	86.7032	24.0834	100	Hard Rock	80
26	KHUNTI	Karra	Safe	Data Scarce Area/quality	Karra	85.1267	23.1284	100	Hard Rock	80
27	KHUNTI	Rania	Safe	Data Scarce Area	Rania	85.1117	22.7675	100	Hard Rock	80
28	KODE RMA	Chandwara	Safe	Data Scarce Area/quality	Chandwara	85.476	24.3893	100	Hard Rock	80
29	KODE RMA	Jainagar	Safe	Data Scarce Area	Jainagar	85.6468	24.374	100	Hard Rock	80

30	KODE RMA	Koderm a	Safe	Urban/quality	Koderm a	85.5933	24.4678	100	Hard Rock	80
31	LATE HAR	Balumat h	Safe	Data Scarce Area	Balumat h	84.7811	23.8386	100	Hard Rock	80
32	LATE HAR	Barwadi h	Safe	Data Scarce Area	Barwadi h	84.1172	23.8477	100	Hard Rock	80
33	LATE HAR	Chandw a	Safe	Data Scarce Area	Chandw a	84.7394	23.677	100	Hard Rock	80
34	LATE HAR	Mahuad anr	Safe	Data Scarce Area	Mahuad anr	84.1065	23.3966	100	Hard Rock	80
35	PAKUR	Amrapar a	Safe	Data Scarce Area/quality	Amrapa ra	87.5719	24.5202	100	Hard Rock	80
36	PAKUR	Hiranpur	Safe	Data Scarce Area	Hiranpu r	87.70488	24.7058	100	Hard Rock	80
37	PAKUR	Mahesh pur	Safe	Data Scarce Area	Mahesh pur	87.7613	24.4746	100	Hard Rock	80
38	PAKUR	Pakuria	Safe	Data Scarce Area/quality	Pakuria	87.6472	24.3347	100	Hard Rock	80
39	RAM GAR H	Mandu	Semi - Critical	Semi-Critical	Mandu	85.471	23.8014	100	Hard Rock	80
40	RAM GAR H	Mandu	Semi - Critical	Data Scarce Area	Hesagar a	85.4682	23.7656	100	Hard Rock	80
41	RAM GAR H	Mandu	Semi - Critical	Data Scarce Area	Tilaiya	85.5101	23.6904	100	Hard Rock	80
42	RANCI	Silli	Critical	Critical/quality	Silli	85.8453	23.3499	100	Hard Rock	80
43	SAHE BGANJ	Udhua	Safe	Arsenic/quality	Udhua	87.8561	24.9682	100	Hard Rock	80
44	SIMDEGA	Bano	Safe	Data Scarce Area	Bano	84.9138	22.6524	100	Hard Rock	80
45	SIMDEGA	Kolebira	Safe	Data Scarce Area	Kolebir a	84.6937	22.7005	100	Hard Rock	80
46	WEST SING HBHUM	Anandpur	Safe	Data Scarce Area	Anandpur	85.1737	22.4705	100	Hard Rock	80
47	WEST SING HBH	Manjhar i	Safe	Data Scarce Area	Manjhar i	85.9295	22.3352	100	Hard Rock	80

	UM									
48	WEST SING HBH UM	Manohar pur	Safe	Data Scarce Area	Manohar pur	85.1973	22.3732	100	Hard Rock	80
49	WEST SING HBH UM	Noamundi	Safe	Data Scarce Area	Noamundi	85.5046	22.159	100	Hard Rock	80
50	WEST SING HBH UM	Sonua	Safe	Data Scarce Area	Sonua	85.4625	22.5823	100	Hard Rock	80

JH PZ BOQ 2

Sl. No	District	Assessment Unit	Category	Priority (Over-Exploited/E/Critical/Semi-critical/Safe/Quality/Urban)	Location of Pz	Longitude	Latitude	Depth of Pz (in m)	Hard/soft Rock	tentative depth (in m) for installation of DWLRs
1	BOKARO	Bermo	OE	OE/Urban	Bermo	85.9357	23.7831	120	Hard Rock	100
2	BOKARO	Bermo	OE	Data Scarce Area	Phusro	86.0204	23.7683	120	Hard Rock	100
3	BOKARO	Chas	Semi-Critical	Semi-Critical/quality	Chas	86.17106	23.6353	120	Hard Rock	100
4	BOKARO	Chas	Semi-Critical	Data Scarce Area	Sanabad	86.14368	23.5809	120	Hard Rock	100
5	BOKARO	Chas	Semi-Critical	Data Scarce Area	Napitjaria	86.20094	23.5356	120	Hard Rock	100
6	CHATRA	Chatra	Safe	Urban	Chatra	84.87138	24.2065	120	Hard Rock	100
7	DEOGHAR	Deoghar	Safe	Urban	Deoghar	86.69502	24.4852	120	Hard Rock	100
8	DEOGHAR	Deoghar	Safe	Data Scarce Area	Kankharajori	86.66414	24.3779	120	Hard Rock	100
9	DEOGHAR	Madhupur	Safe	Urban	Madhupur	86.64685	24.2658	120	Hard Rock	100

10	DHANBAD	Chirkunda	Safe	Urban	Chirkunda	86.7 8655	23.7 485	12 0	Hard Rock	100
11	DHANBAD	Dhanbad	Semi-Critical	Urban/Semi-Critical	Dhanbad	86.4 3104	23.7 958	12 0	Hard Rock	100
12	DHANBAD	Dhanbad	Semi-Critical	Data Scarce Area	Saraydhela	86.4 678	23.8 186	12 0	Hard Rock	100
13	DHANBAD	Dhanbad	Semi-Critical	Data Scarce Area	Chirudih	86.3 5193	23.7 59	12 0	Hard Rock	100
14	DHANBAD	Dhanbad	Semi-Critical	Data Scarce Area	Majhildih	86.3 388	23.7 177	12 0	Hard Rock	100
15	DUMKA	Dumka	Safe	Urban	Dumka	87.2 4816	24.2 697	12 0	Hard Rock	100
16	EAST SINGHBHUM	Golmuri cum jugsalai	OE	OE	Dungitola	86.2 0142	22.7 19	12 0	Hard Rock	100
17	EAST SINGHBHUM	Golmuri cum jugsalai	OE	Data Scarce Area	Bandih	86.2 9759	22.7 63	12 0	Hard Rock	100
18	EAST SINGHBHUM	Golmuri cum jugsalai	OE	Data Scarce Area	Bagra	86.2 884	22.8 141	12 0	Hard Rock	100
19	EAST SINGHBHUM	Golmuri cum jugsalai	OE	Data Scarce Area	Belajuri	86.3 6598	22.7 397	12 0	Hard Rock	100
20	GIRIDIH	Giridih	Safe	Urban/quality	Giridih	86.2 994	24.1 92	12 0	Hard Rock	100
21	GIRIDIH	Saria	Safe	Data Scarce Area	Saria	85.8 915	24.1 881	12 0	Hard Rock	100
22	GODDA	Godda	Safe	Urban/quality	Godda	87.2 136	24.8 262	12 0	Hard Rock	100
23	GUMLA	Gumla	Safe	Urban/quality	Gumla	84.5 378	23.0 445	12 0	Hard Rock	100
24	HAZARIBAGH	Hazaribagh	Safe	Urban	Hazaribagh	85.3 635	23.9 938	12 0	Hard Rock	100
25	JAMTARA	Jamtara	Safe	Urban	Jamtara	86.8 161	23.9 518	12 0	Hard Rock	100
26	KHUNTI	Khunti	Safe	Urban	Khunti	85.2 774	23.0 804	12 0	Hard Rock	100
27	LATEHAR	Latehar	Safe	Urban	Latehar	84.5 092	23.7 467	12 0	Hard Rock	100

									k	
28	LOHARDA GA	Lohardaga	Safe	Urban	Lohardaga	84.6849	23.4423	120	Hard Rock	100
29	PAKUR	Pakur	Safe	Urban	Pakur	87.8498	24.6337	120	Hard Rock	100
30	Palamu	Daltonganj	Safe	Urban/quality	Nawadih	84.187	23.9727	120	Hard Rock	100
31	RANCHI	Kanke	Semi-Critical	Semi-Critical	Pithauria	85.28955	23.5184	120	Hard Rock	100
32	RANCHI	Khelari	Semi-Critical	Semi-Critical	Ray	85.0537	23.6812	120	Hard Rock	100
33	SIMDEGA	Simdega	Safe	Urban	Simdega	84.4959	22.6158	120	Hard Rock	100
34	WEST SINGHBHUM	Chaibasa	Safe	Urban	Chaibasa	85.8026	22.5478	120	Hard Rock	100
35	WEST SINGHBHUM	Chakradharpur	Safe	Urban	Chakradharpur	85.6254	22.6768	120	Hard Rock	100

UP PZ BOQ 1								
S_No_	District	Assessment_unit	Name_of_Village	Longitude	Latitude	Priority_areaif_oter_than_OCS_	Proposed_Depth	Tentative_depth_of_installation_of_DWLR_m_
1	AGRA	Jagner	Bargawan Khurd	77.5728	26.8719	OCS	50	22.00
2	AGRA	Fatehpur Sikri	Kandau Barau	77.6707	27.0857	OCS	50	21.00
3	AGRA	Achhnera	Janutha	77.7936	27.2002	OCS	50	21.00
4	BANDA	Kamasin	Kamasin	80.8666	25.5215	Next to OCS Block	50	16.00
5	BANDA	Bisanda	Bagha	80.7168	25.3875	Next to OCS Block	50	16.00
6	BANDA	Barokhar	Mahokhar	80.3795	25.5036	Next to OCS Block	50	14.00
7	BANDA	Naraini	Nibi	80.5475	25.1347	OCS	50	14.00
8	BANDA	Mahuva	Kherwa	80.4594	25.3056	Next to OCS Block	50	9.00
9	CHITRAKOO	Pahari1	Sursen	81.0581	25.4638	OCS	50	14.00

	T							
10	HAMI RPUR	Maudaha	Sijnaura	80.14 69	25.63 86	Next to OCS Block	50	18.00
11	HAMI RPUR	Muskara	Gaura	79.85 43	25.64 13	Next to OCS Block	50	17.00
12	HAMI RPUR	Rath	Itora Rath	79.50 99	25.57 87	OCS	50	23.00
13	HAMI RPUR	Gohand	Kemokhar	79.55 65	25.70 55	OCS	50	25.00
14	JHANS I	Bangra	Garaha	79.18 91	25.49 62	OCS	50	18.00
15	JHANS I	Baragaon1	Garhmau	78.67 47	25.49 49	OCS	50	15.00
16	LALIT PUR	Talbehat	Sunauri	78.50 19	25.03 45	OCS	50	18.00
17	LALIT PUR	Jakhora	Dailwara	78.35 66	24.77 6	OCS	50	18.00
18	LALIT PUR	Birdha	Magar Pur	78.44	24.52 41	OCS	50	18.00
19	LALIT PUR	Bar	Burogaon	78.63 53	24.80 47	OCS	50	18.00
20	LALIT PUR	Mahroni	Kumehri	78.77 46	24.52 62	OCS	50	17.00
21	LALIT PUR	Madaora	Bamhori Kalan	78.74 26	24.35 26	OCS	50	17.00
22	PRAY AGRA J	Uruwan	Bisenpur	82.15 95	25.25 42	Next to OCS Block	50	19.00
23	PRAY AGRA J	Karchana	Khain	81.98 07	25.23 4	Next to OCS Block	50	19.00
24	PRAY AGRA J	Jasra	Pandar	81.77 09	25.28 3	Next to OCS Block	50	15.00
25	PRAY AGRA J	Shankargarh	Bhelaon	81.69 42	25.19 74	Next to OCS Block	50	15.00
26	PRAY AGRA J	Kaudhiyara	Peeri	81.89 37	25.19 16	Next to OCS Block	50	15.00
27	SONB HADR A	Nagawa	Lorha	83.41 35	24.58 88	OCS	50	14.00
28	SONB HADR A	Dudhi	Forest, un- inhabited	83.15 19	24.22 57	OCS	50	16.00

UP PZ BOQ 2

S_No_	District	Assessment_ unit	Name_of_ Village	Longi tude	Latitu de	Priority_areaif_ot her_than_OCS_	Proposed _Depth	Tentative _depth__ of_install ation__of _DWLR_ _m_
1	AGRA	Fatehabad	Fatehabad (NP)	78.30 79	27.01 69	OCS	100	53.00

2	AGRA	Shamsabad I	Patti Shaikhpur	78.10 93	27.01 39	OCS	100	60.00
3	AGRA	Saiyana	Mohanpur	77.98 71	26.95 72	OCS	100	50.00
4	AGRA	Barauli Ahir	Bamrauli Katara	78.09 84	27.11 56	OCS	100	54.00
5	AGRA	Agra Urban	Agra (M Corp.)	78.05 59	27.15 58	Urban Shallow	100	50.00
6	AGRA	Pinahat	Pinaht Dehat	78.38 02	26.90 26	Next to OCS Block	100	42.00
7	AGRA	Bah	Narholi	78.54 12	26.85 88	OCS	100	40.00
8	AGRA	Agra Urban	Agra (M Corp.)	78.01 93	27.18 7	Urban Shallow	100	47.00
9	AGRA	Agra Urban	Agra (CB)	78.05 09	27.22 06	Urban Shallow	100	44.00
10	AGRA	Agra Urban	Agra (M Corp.)	78.00 35	27.15 9	Urban Shallow	100	46.00
11	AGRA	Etmadpur	Mitaoli	78.18 82	27.29 68	OCS	100	41.00
12	AGRA	Khandauli	Uncha	78.08 56	27.29 14	OCS	100	38.00
13	AGRA	Jaitpur Kalan	Mau	78.76 08	26.82 05	OCS	100	44.00
14	AGRA	Kheragarh	Bhilawali	77.81 87	26.96 8	OCS	100	33.00
15	AGRA	Agra Urban	Agra (M Corp.)	77.97 1	27.21 65	Urban Shallow	100	33.00
16	AGRA	Bichpuri	Barara	77.90 88	27.14 12	OCS	100	31.00
17	AGRA	Akola	Ujarai	77.87 41	27.08 38	OCS	100	24.00
18	ALIGARH	Aligarh Urban	Asadpur Kayam	78.10 62	27.87 9	Urban Shallow	100	37.00
19	ALIGARH	Aligarh Urban	Aligarh (M Corp.)	78.07 35	27.89 33	Urban Shallow	100	36.00
20	ALIGARH	Aligarh Urban	Aligarh (M Corp.)	78.06 14	27.86 97	Urban Shallow	100	37.00
21	ALIGARH	Aligarh Urban	Aligarh (M Corp.)	78.09 18	27.91 21	Urban Shallow	100	35.00
22	ALIGARH	Aligarh Urban	Sarsaul (CT)	78.04 48	27.91 23	Urban Shallow	100	35.00
23	ALIGARH	Lodha	Keshopur Jophri	77.98 97	27.88 44	OCS	100	33.00
24	ALIGARH	Tappal	Jahan Garh	77.57 92	28.01 35	Next to OCS Block	100	27.00
25	ALIGARH	Chandaus	Chandaus	77.86 12	28.06 63	OCS	100	32.00
26	ALIGARH	Dhanipur	Khan Alampur	78.19 16	27.88 31	Next to OCS Block	100	30.00
27	ALIGARH	Jawa Sikandairpur	Jawan Sikandpur	78.10 8	28.03 29	OCS	100	28.00
28	ALIGARH	Gangiri	Galibpur	78.44 56	27.88 23	OCS	100	24.00
29	ALIGARH	Bijauli	Mandpur	78.44 63	28.01 6	Next to OCS Block	100	22.00
30	ALIGARH	Atrauli	Rajmargpur	78.30 08	28.06 86	Next to OCS Block	100	21.00
31	ALIGARH	Gonda	Chhaichha u	77.86 24	27.71 38	Next to OCS Block	100	20.00

32	ALIGARH	Khair	Khair (NPP)	77.84 52	27.94 49	OCS	100	22.00
33	ALIGARH	Iglas	Madaura	77.95 9	27.69 4	OCS	100	25.00
34	ALIGARH	Akrabad	Akarabad	78.27 76	27.79 51	Next to OCS Block	100	9.00
35	AMBEDKARNAGAR	Jalalpur1	Malikpur Chhitooni	82.69 42	26.32 34	OCS	100	11.00
36	AMETHI	Sangrampur	Bhausinghpur	81.84 44	26.07 94	OCS	100	20.00
37	AMROHA	Joya	Sudanpur	78.41 56	28.85 64	OCS	100	23.00
38	AMROHA	Hasanpur	Habaitpur Banjara	78.32 9	28.71 72	OCS	100	28.00
39	AMROHA	Amroha	Apraula Maybag	78.45 37	28.97 46	OCS	100	18.00
40	AMROHA	Gangeshwari	Banska Madaripur	78.25 32	28.60 83	OCS	100	22.00
41	AMROHA	Dhanaura	Dehari Bujurg	78.18 97	28.97 7	OCS	100	16.00
42	AMROHA	Gajraula	Kumrala Bhadurpur	78.19 54	28.85 18	OCS	100	17.00
43	AURAIYA	Sahar	Asu	79.63 5	26.68 82	Next to OCS Block	100	12.00
44	AURAIYA	Bidhuna	Bahdhmau	79.59 77	26.81 78	Next to OCS Block	100	11.00
45	AURAIYA	Erwa Katra	Bhedpur	79.41 25	26.85 64	Next to OCS Block	100	11.00
46	AYODHYA	Milkipur	Kinauli	81.93 98	26.62 81	OCS	100	12.00
47	AYODHYA	Bikapur	Bikapur (NP)	82.14 35	26.57 62	OCS	100	11.00
48	AZAMGARH	Palhana	Pawani Khurd	83.10 95	25.80 36	OCS	100	14.00
49	AZAMGARH	Tarwa	Bangaon	83.18 35	25.72 15	OCS	100	14.00
50	AZAMGARH	Sathiyaon	Bhatora	83.28 82	26.04 78	OCS	100	13.00
51	AZAMGARH	Palhani	Azamgarh (NPP)	83.18 78	26.05 54	OCS	100	13.00
52	AZAMGARH	Lalganj1	Katghar Lalganj (NP)	82.99 63	25.8	Next to OCS Block	100	13.00
53	AZAMGARH	Ahiraula	Itaura	82.91 81	26.18 13	OCS	100	14.00
54	AZAMGARH	Koilsa	Ekdangi	83.02 03	26.25 65	OCS	100	13.00
55	AZAMGARH	Atraulia	Kantalpur	82.93 11	26.33 1	OCS	100	12.00
56	BAGPAT	Binauli	Begamabad Garhi	77.39 68	29.13 84	OCS	100	32.00
57	BAGPAT	Khekra	Rataul	77.34 87	28.83 32	OCS	100	30.00
58	BAGPAT	Baraut	Mahavatpur	77.25 24	29.12 15	OCS	100	28.00
59	BAGPAT	Chhaprauli	Rathaura	77.21 77	29.22 42	OCS	100	23.00
60	BANDA	Baberu	Hardoulee	80.69 39	25.57 24	OCS	100	17.00

61	BAREILLY	Majhgawa	Bheekampur	79.28 32	28.32 68	OCS	100	29.00
62	BAREILLY	Alampur Jafarabad	Keona Sadipuur	79.30 01	28.22 56	OCS	100	30.00
63	BAREILLY	Kyara	Ajampur Mustaqil	79.36 07	28.36 29	Next to OCS Block	100	29.00
64	Bareilly	Bareilly Urban	Bareilly (M Corp. + OG)	79.36 19	28.42 4	Urban Shallow	100	30.00
65	Bareilly	Bareilly Urban	Bareilly (M Corp. + OG)	79.45 2	28.32 83	Urban Shallow	100	29.00
66	Bareilly	Bareilly Urban	Bareilly (M Corp. + OG)	79.41 83	28.38 85	Urban Shallow	100	29.00
67	Bareilly	Bareilly Urban	Bareilly (M Corp. + OG)	79.43 85	28.41 84	Urban Shallow	100	29.00
68	BAREILLY	Fatehganj	Sorha	79.34	28.51	OCS	100	31.00
69	Bareilly	Bareilly Urban	Bareilly (M Corp. + OG)	79.45 41	28.37 92	Urban Shallow	100	29.00
70	BAREILLY	Meerganj	Hurhuri	79.23 75	28.51 56	Next to OCS Block	100	31.00
71	BAREILLY	Bhojpura	Ghanghousa Ghanghori	79.43 69	28.48 37	Next to OCS Block	100	29.00
72	BAREILLY	Bitheri Chainpur	Bhagwanpur Dhimri	79.54 06	28.39 17	Next to OCS Block	100	28.00
73	BAREILLY	Ramnagar3	Devsara Urf Sangrampur	79.08 3	28.41 32	OCS	100	25.00
74	BAREILLY	Shergarh	Kabra Kishanpur	79.33 25	28.66 2	Next to OCS Block	100	26.00
75	BIJNOR	Kiratpur	Khasour	78.24 61	29.49 11	Next to OCS Block	100	16.00
76	BIJNOR	Mohammadpur Deomal	Jamalpur Pathani	78.13 39	29.41 97	Next to OCS Block	100	15.00
77	BIJNOR	Najibabad	Gulalwali	78.32 56	29.68 3	Next to OCS Block	100	14.00
78	BIJNOR	Haldaur (Khari Jhalu)	Kadarpur	78.21 92	29.29 26	Next to OCS Block	100	15.00
79	BIJNOR	Jaleelpur	Chak Mehmoodpur	78.21 91	29.11 84	OCS	100	15.00
80	BIJNOR	Seohara (Budhanpur)	Khanpur	78.55 4	29.13 46	OCS	100	14.00
81	BIJNOR	Dhanpur (Alhepur)	Moh Ali Pur Madho Ahatmali	78.55 93	29.30 46	Next to OCS Block	100	13.00
82	BIJNOR	Nehtaur (Aaku)	Basera Khurd	78.42 85	29.25 25	OCS	100	13.00
83	BIJNOR	Afzalgarh	Shivpuri	78.71 21	29.41 33	Next to OCS Block	100	13.00
84	BIJNOR	Noorpur	Jhiran	78.41 89	29.13 03	OCS	100	13.00
85	BIJNOR	Kotwali	Islamabad	78.49 96	29.48 59	OCS	100	12.00

86	BUDA UN	Dataganj	Diyori	79.41 08	27.98 9	Next to OCS Block	100	28.00
87	BUDA UN	Wazirganj1	Nandwari	79.03 44	28.22 56	Next to OCS Block	100	30.00
88	BUDA UN	Salarpur	Raipura	79.26 79	28.13 61	OCS	100	30.00
89	BUDA UN	Ambiapur	Simribhojpur	78.95 76	28.15 55	OCS	100	30.00
90	BUDA UN	Samrer	Samrer	79.40 91	28.09 82	Next to OCS Block	100	28.00
91	BUDA UN	Islamnagar	Abdulvahidpur Urf Papsara	78.74 35	28.31 69	OCS	100	31.00
92	BUDA UN	Bisauli	Nibhera Sarvarpur	78.84 73	28.28 94	OCS	100	30.00
93	BUDA UN	Asafpur	Asafpur Phakawali	78.92 14	28.39 27	OCS	100	26.00
94	BUDA UN	Sahaswan	Lalpur	78.77 16	28.08 31	OCS	100	28.00
95	BUDA UN	Quadar Chowk	Kakora	79.06 16	27.90 27	OCS	100	24.00
96	BUDA UN	Dahgawan	Rasoolpur Kala	78.64 05	28.18 76	Next to OCS Block	100	22.00
97	BUDA UN	Jagat	Gurgavan	79.22 93	28.00 2	OCS	100	24.00
98	BUDA UN	Miaon	Gautarapati Narpatt Khurd	79.33 15	27.86 78	OCS	100	22.00
99	BUDA UN	Ujhani	Rionaia	78.90 07	27.98 68	OCS	100	23.00
100	BUDA UN	Usawan	Kheda Jalalpur Pukhta	79.27 13	27.74 73	Next to OCS Block	100	16.00
101	BULA NDSH AHAR	Debai	Retuka Nagla/Maharajpur	78.41 75	28.13 96	Next to OCS Block	100	22.00
102	BULA NDSH AHAR	Danpur	Nagla Chhattu	78.23 11	28.15 73	OCS	100	21.00
103	BULA NDSH AHAR	Jahangirabad	Jadaul	78.05 97	28.46 42	OCS	100	25.00
104	BULA NDSH AHAR	Gulaothi	Saidpur Khurampur	77.81 7	28.54 91	OCS	100	20.00
105	BULA NDSH AHAR	Unchagaon	Narsena	78.14 59	28.53 01	OCS	100	22.00
106	BULA NDSH AHAR	Siana	Siyana	78.05 13	28.62 29	OCS	100	21.00
107	BULA NDSH AHAR	Pahasu	Kuwarpur	78.10 31	28.17 64	OCS	100	21.00
108	BULA NDSH AHAR	Shikarpur	Jalalpur Karira	78.02 21	28.32 18	OCS	100	20.00
109	BULA NDSH AHAR	Arnia Khurd	Gworoli Bhojgarhi	77.94 82	28.17 52	OCS	100	22.00
110	BULA	Khurja	Sikri	77.80	28.23	OCS	100	20.00

	NDSH AHAR			52	79			
111	BULA NDSH AHAR	Bhawan Bahadur Nagar	Kharkali	77.9405	28.6422	OCS	100	20.00
112	BULA NDSH AHAR	Anup shahar	Aniwas	78.2149	28.3578	OCS	100	18.00
113	BULA NDSH AHAR	Lakhaothi	Charaura Mustafabad	77.9475	28.4787	OCS	100	17.00
114	BULA NDSH AHAR	Sikandrabad	Saraidulha	77.7259	28.4299	OCS	100	17.00
115	BULA NDSH AHAR	Bulandshahr	Bulandshahr (NPP + OG)	77.8547	28.4127	OCS	100	16.00
116	ETAH	Jalesar	Shakrauli	78.3066	27.4018	OCS	100	34.00
117	ETAH	Aliganj	Mihuta	79.179	27.4688	OCS	100	24.00
118	ETAH	Nidhauili Kalan	Baragaon	78.554	27.5881	OCS	100	24.00
119	ETAH	Marhara	Lodhamai	78.6639	27.7029	Next to OCS Block	100	15.00
120	ETAH	Awagarh	Misakalan	78.4331	27.4792	Next to OCS Block	100	22.00
121	ETAH	Jaithara	Targawan	78.9739	27.4738	OCS	100	15.00
122	ETAH	Sakit	Sakit (NP)	78.7815	27.4507	OCS	100	14.00
123	ETAH	Shitalpur	Dhuayai	78.7569	27.5781	OCS	100	13.00
124	ETAW AH	Jaswantnagar	Jaswantnagar (NPP)	78.9071	26.8797	Next to OCS Block	100	32.00
125	ETAW AH	Barahpura	Kamet	78.9728	26.7404	<Null>	100	33.00
126	ETAW AH	Basrehar	Shankarpur	79.1041	26.8437	Next to OCS Block	100	19.00
127	ETAW AH	Bharthna	Ramain	79.2316	26.7767	Next to OCS Block	100	15.00
128	ETAW AH	Takha	Kharag Pur Sariya	79.2729	26.9085	Next to OCS Block	100	11.00
129	FARR UKHABAD	Kamalganj	Usman Ganj	79.5871	27.2456	OCS	100	28.00
130	FARR UKHABAD	Barhpur	Farrukhabad-cum-Fatehgarh (NPP)	79.5683	27.3908	OCS	100	25.00
131	FARR UKHABAD	Mohamadabad1	Daudpur Nagla Bagrathaura	79.369	27.2838	OCS	100	23.00
132	FARR UKHABAD	Shamsabad2	Parashram pur Patti	79.4862	27.527	Next to OCS Block	100	21.00
133	FARR UKHABAD	Rajepur	Emadpur Sombansi	79.6443	27.4742	Next to OCS Block	100	19.00
134	FARR	Nawabganj3	Jiouni	79.35	27.46	OCS	100	16.00

	UKHA BAD			97	92			
135	FARR UKHA BAD	Kaimganj	Jogpur	79.29 54	27.59 93	<Null>	100	14.00
136	FATE HPUR	Dhata	Balaie	81.19 05	25.54 06	Next to OCS Block	100	6.00
137	FATE HPUR	Vijayipur	Rari	81.08 78	25.61 24	Next to OCS Block	100	20.00
138	FATE HPUR	Khajuha	Mansoorpu r	80.51 23	25.94 18	OCS	100	24.00
139	FATE HPUR	Haswa	Khumaripu r	80.95 07	25.83 7	Next to OCS Block	100	24.00
140	FATE HPUR	Hathgaon	Sithaura	81.13 56	25.91 34	Next to OCS Block	100	21.00
141	FATE HPUR	Malawan	Rustampur	80.61 39	26.07 18	OCS	100	22.00
142	FATE HPUR	Telyani	Korai	80.75 05	25.95 91	OCS	100	22.00
143	FATE HPUR	Amauli	Lakhamipu r	80.34 31	26.01 24	OCS	100	22.00
144	FATE HPUR	Bahua	Bara Gaon	80.66 57	25.79 84	Next to OCS Block	100	20.00
145	FATE HPUR	Deomai	Bhelgaon	80.42 35	26.10 22	Next to OCS Block	100	20.00
146	FATE HPUR	Bhitaura	Aodhera	80.94 98	25.98 09	OCS	100	19.00
147	FATE HPUR	Airaya	Semoori	81.20 01	25.78 55	OCS	100	16.00
148	FATE HPUR	Asodhar	Sarkandi	80.90 86	25.72 23	Next to OCS Block	100	15.00
149	FIROZ ABAD	Firozabad	Nasirpur	78.40 9	27.11 16	OCS	100	51.00
150	FIROZ ABAD	Khairgarh	Kanvara	78.48 61	27.21 63	OCS	100	46.00
151	FIROZ ABAD	Tundla	Chulhaoli	78.26 06	27.19 08	OCS	100	47.00
152	FIROZ ABAD	Shikohabad	Owari	78.55 79	27.06 84	OCS	100	39.00
153	FIROZ ABAD	Narkhi	Garhi Hansram	78.39 09	27.27 73	OCS	100	45.00
154	FIROZ ABAD	Aron	Baijuakhas	78.72 09	27.12 23	OCS	100	34.00
155	FIROZ ABAD	Jasrana	Jhapara	78.64 73	27.26 98	OCS	100	31.00
156	FIROZ ABAD	Madanpur	Muzaffarp ur	78.68 43	26.99 21	OCS	100	27.00
157	FIROZ ABAD	Eka	Thati	78.56 3	27.40 18	OCS	100	24.00
158	G.B.N AGAR	Bisrakh	Noida (CT)	77.38 36	28.56 25	OCS	100	36.00
159	G.B.N AGAR	Jewar	Ranhara	77.61 24	28.18 22	OCS	100	23.00
160	G.B.N AGAR	Dadri	Phoolpur	77.59 71	28.54 18	OCS	100	23.00
161	G.B.N AGAR	Dankaur	Amarpur	77.57 06	28.37 82	OCS	100	17.00
162	GHAZI ABAD	Loni	Sharfuddin pur Javli	77.35 01	28.74 39	OCS	100	25.00
163	GHAZI ABAD	Gaziabad Urban	Ghaziabad (M Corp.)	77.34 55	28.68 74	Urban Shallow	100	27.00

164	GHAZI ABAD	Gaziabad Urban	Noida (CT)	77.34 34	28.65 16	Urban Shallow	100	28.00
165	GHAZI ABAD	Gaziabad Urban	Ghaziabad (M Corp.)	77.40 9	28.66 83	Urban Shallow	100	28.00
166	GHAZI ABAD	Gaziabad Urban	Ghaziabad (M Corp.)	77.48 98	28.65 9	Urban Shallow	100	26.00
167	GHAZI ABAD	Gaziabad Urban	Ghaziabad (M Corp.)	77.47 61	28.70 4	Urban Shallow	100	26.00
168	GHAZI ABAD	Razapur	Kushaliya	77.54 68	28.71 63	OCS	100	23.00
169	GHAZI ABAD	Bhojpur	Shahjahan pur	77.61 93	28.82 81	OCS	100	21.00
170	GHAZI ABAD	Muradnagar	Kaithwadi	77.48 44	28.83 1	OCS	100	15.00
171	GHAZI PUR	Saidpur	Dhara	83.15 63	25.57 33	OCS	100	13.00
172	HAPU R	Hapur	Sultanpur	77.81 28	28.69 81	OCS	100	24.00
173	HAPU R	Simbholi	Rajpur	77.94 74	28.77 37	OCS	100	24.00
174	HAPU R	Dholana	Dhaulana	77.65 57	28.64 47	OCS	100	23.00
175	HAPU R	Garh	Salarpur	78.09 89	28.74 18	OCS	100	19.00
176	HARD OI	Todarpur	Singoha	80.05 39	27.65 09	OCS	100	21.00
177	HATH RAS	Sadabad	Dagsah	77.98 64	27.39 66	OCS	100	31.00
178	HATH RAS	Sasni	Nagala Bijaiya	78.10 52	27.69 81	OCS	100	32.00
179	HATH RAS	Mursan	Nagla Bihari	77.98 27	27.55 25	OCS	100	41.00
180	HATH RAS	Sahpau	Khonda	78.11 89	27.45 19	OCS	100	31.00
181	HATH RAS	Hathras	Jalalpur Shahjadpur	78.14 55	27.57 16	OCS	100	24.00
182	HATH RAS	Hasayan	Nagaria Patti Devari	78.32 43	27.64 13	Next to OCS Block	100	15.00
183	HATH RAS	Sikandra Rao	Bartar Khas	78.43 39	27.74 41	OCS	100	9.00
184	JAUNP UR	Sirkoni	Kadeepur	82.73 43	25.66 82	OCS	100	22.00
185	JAUNP UR	Kerakat	Narhan	82.92 74	25.62 34	OCS	100	18.00
186	JAUNP UR	Badlapur	Tiyara	82.46 78	25.93 29	OCS	100	16.00
187	JAUNP UR	Karanja Kalan	Palhamau	82.66 63	25.80 22	OCS	100	18.00
188	JAUNP UR	Dobhi	Kasili	83.01 93	25.64 02	Next to OCS Block	100	14.00
189	JAUNP UR	Jalalpur2	Rehati	82.79 14	25.59 3	Next to OCS Block	100	17.00
190	JAUNP UR	Baksha	Tikari	82.52 17	25.82 59	OCS	100	15.00
191	JAUNP UR	Rampur	Patti Jiya Rai	82.64 63	25.46 22	Next to OCS Block	100	14.00
192	JAUNP UR	Muftiganj	Bagthari	82.86 16	25.71 1	OCS	100	15.00
193	JAUNP UR	Mariahu	Khajuraha van	82.57 19	25.65 65	Next to OCS Block	100	15.00

194	JAUNPUR	Sujanganj	Tazuddinpur Khas	82.2489	25.7653	Next to OCS Block	100	13.00
195	JAUNPUR	Barsathi	Sarsara Mafi	82.4764	25.5605	OCS	100	10.00
196	JAUNPUR	Mungra Badshahpur	Bijadhar Mau	82.2259	25.6455	Next to OCS Block	100	11.00
197	JAUNPUR	Maharajanj 2	Barhupur	82.353	25.8519	OCS	100	12.00
198	JAUNPUR	Dharmapur	Tarsand	82.7742	25.751	OCS	100	14.00
199	JAUNPUR	Sikrara	Tahirpur	82.5473	25.7276	OCS	100	13.00
200	JAUNPUR	Machhlishahr	Jagadishpur Khas	82.3717	25.603	Next to OCS Block	100	9.00
201	JAUNPUR	Ramnagar6	Padrav	82.6575	25.557	Next to OCS Block	100	12.00
202	KANNAUJ	Jalalabad1	Fatehpur	79.8014	27.0722	OCS	100	37.00
203	KANNAUJ	Kannauj	Chandi Mustafabad	79.8996	27.0236	OCS	100	31.00
204	KANNAUJ	Gograpur	Mahmudpur gang	79.8262	27.1453	OCS	100	32.00
205	KANNAUJ	Talgram	Tusauli	79.6838	27.0904	OCS	100	31.00
206	KANNAUJ	Chhibramau	Nigoh Khas	79.4561	27.1521	OCS	100	19.00
207	KANNAUJ	Saurikh	Husnepur	79.483	26.9908	Next to OCS Block	100	18.00
208	KANNAUJ	Umarda	Tilsara	79.8034	26.9004	Next to OCS Block	100	16.00
209	KANNAUJ	Haseran	Haseran	79.5702	26.9273	Next to OCS Block	100	12.00
210	KANPUR DEHAT	Rajpur	Nandana	79.6524	26.3286	Next to OCS Block	100	32.00
211	KANPUR DEHAT	Malsa	Deega	79.8877	26.2799	OCS	100	23.00
212	KANPUR DEHAT	Amraudha	Nonapur	79.8341	26.1821	Next to OCS Block	100	22.00
213	KANPUR DEHAT	Derapur	Udnapur	79.812	26.4445	OCS	100	20.00
214	KANPUR DEHAT	Sarwan Khera	Surajpur	80.0772	26.3559	OCS	100	22.00
215	KANPUR DEHAT	Akbarpur2	Banna Jakha	79.9502	26.4296	OCS	100	20.00
216	KANPUR DEHAT	Sandalpur	Hawaspur	79.6749	26.4434	Next to OCS Block	100	18.00

217	KANPUR DEHAT	Maitha	Marag	80.0598	26.532	OCS	100	20.00
218	KANPUR DEHAT	Jhinhak	Nahili	79.7533	26.5634	OCS	100	16.00
219	KANPUR DEHAT	Rasulabad	Bahadurpur	79.81	26.6716	OCS	100	12.00
220	KANPUR NAGAR	Parara	Tejpur	80.1461	26.2258	OCS	100	26.00
221	KANPUR NAGAR	Ghatampur	Makrandpur Bangar	80.0904	26.1035	OCS	100	26.00
222	KANPUR NAGAR	Bilhaur	Sihura Dara Shikoh	80.0257	26.8282	OCS	100	19.00
223	KANPUR NAGAR	Bhitargaon	Palpur	80.3138	26.211	Next to OCS Block	100	18.00
224	KANPUR NAGAR	Sarsol	Sarsaul	80.4772	26.2796	OCS	100	16.00
225	KANPUR NAGAR	Bidhnu	Jamoo	80.264	26.3324	OCS	100	17.00
226	KANPUR NAGAR	Kanpur Urban	Kanpur (M Corp. + OG)	80.4139	26.3703	Urban Shallow	100	15.00
227	KANPUR NAGAR	Chaubepur	Choubepur Kalan (CT)	80.2053	26.6154	OCS	100	16.00
228	KANPUR NAGAR	Kanpur Urban	Kanpur (M Corp. + OG)	80.4408	26.3912	Urban Shallow	100	15.00
229	KANPUR NAGAR	Kanpur Urban	Kanpur (M Corp. + OG)	80.3262	26.3993	Urban Shallow	100	15.00
230	KANPUR NAGAR	Kanpur Urban	Kanpur (CB)	80.3698	26.4253	Urban Shallow	100	15.00
231	KANPUR NAGAR	Kanpur Urban	Kanpur (M Corp. + OG)	80.2827	26.4894	Urban Shallow	100	15.00
232	KANPUR	Kakwan	Rasoolpur Rasoolaba	79.9149	26.7401	Next to OCS Block	100	15.00

	NAGA R		d					
233	KANP UR NAGA R	Shivrajapur	Biramau	80.06 55	26.68 23	OCS	100	13.00
234	KASG ANJ	Kasganj	Barkhurdar Pur	78.61 33	27.81 77	OCS	100	16.00
235	KASG ANJ	Soron	Fatehpur Kalan	78.69 59	27.91 54	Next to OCS Block	100	15.00
236	KASG ANJ	Ganjdundwa ra	Nababganj Nagariya	79.04 33	27.78 1	OCS	100	15.00
237	KASG ANJ	Amanpur	Tharachita ra	78.77 48	27.73 91	Next to OCS Block	100	14.00
238	KASG ANJ	Sahawar	Roshan Nagar	78.83 41	27.84 01	OCS	100	15.00
239	KASG ANJ	Patiyali	Nagria Gaur	79.06 56	27.65 04	OCS	100	10.00
240	KASG ANJ	Sidhpura	Kalyani	78.90 09	27.65 7	Next to OCS Block	100	12.00
241	KAUS HAMB I	Kara	Parash	81.28 75	25.72 35	OCS	100	16.00
242	KAUS HAMB I	Newada	Hasanpur	81.54 24	25.34 66	OCS	100	23.00
243	KAUS HAMB I	Muratganj	Lohra	81.57 45	25.52 76	OCS	100	71.00
244	KAUS HAMB I	Sarsawan	Pashchim Sharira	81.30 08	25.40 9	Next to OCS Block	100	17.00
245	KAUS HAMB I	Manjhanpur	Pandiri	81.41 44	25.47 76	OCS	100	20.00
246	KAUS HAMB I	Sirathu	Manmau	81.39 65	25.57 38	OCS	100	14.00
247	KAUS HAMB I	Kaushambi	Jadhi	81.45 06	25.36 08	Next to OCS Block	100	26.00
248	KAUS HAMB I	Chail	Balipur Tata	81.58 5	25.46 41	OCS	100	7.00
249	LUCK NOW	Lucknow Urban	Lucknow (M Corp.)	80.91 78	26.77 57	Urban Shallow	100	19.00
250	LUCK NOW	Lucknow Urban	Sarsawan (CT)	80.98 96	26.80 15	Urban Shallow	100	19.00
251	LUCK NOW	Lucknow Urban	Lucknow (M Corp.)	80.92 33	26.83 59	Urban Shallow	100	19.00
252	LUCK NOW	Lucknow Urban	Lucknow (M Corp.)	81.03 52	26.89 11	Urban Shallow	100	18.00
253	LUCK NOW	Lucknow Urban	Lucknow (M Corp.)	80.94 64	26.92 48	Urban Shallow	100	18.00
254	MAIN PURI	Ghiror	Bhugai	78.80 51	27.24 49	Next to OCS Block	100	21.00
255	MAIN PURI	Kurawali	Vishunpur	78.93 69	27.37 43	OCS	100	21.00
256	MAIN PURI	Barnahal	Dhakpura	78.87 82	27.05 45	OCS	100	21.00
257	MAIN	Bewar	Dhumaspu	79.33	27.16	Next to OCS	100	18.00

	PURI		r	71	5	Block		
258	MAIN PURI	Sultanganj	Chhachha	79.14 47	27.29 39	Next to OCS Block	100	17.00
259	MAIN PURI	Mainpuri	Auden Mandal	78.98 03	27.21 57	OCS	100	15.00
260	MAIN PURI	Kishni	Saunasee	79.27 75	27.04 15	Next to OCS Block	100	13.00
261	MAIN PURI	Karhal	Nadrela	78.99 26	27.02 02	Next to OCS Block	100	12.00
262	MAIN PURI	Jagir	Hatpau	79.13 69	27.15 5	OCS	100	13.00
263	MATH URA	Raya	Rausinga	77.81 28	27.53 77	OCS	100	29.00
264	MATH URA	Nohjhil	Baroth Bangar	77.68 26	27.84 86	OCS	100	19.00
265	MATH URA	Mat	Javara	77.75 39	27.66 36	Next to OCS Block	100	26.00
266	MATH URA	Nandgaon	Kamar	77.36 88	27.80 2	Next to OCS Block	100	19.00
267	MATH URA	Chhata	Husaini	77.55 48	27.77 33	Next to OCS Block	100	20.00
268	MATH URA	Baldeo	Angai	77.83 81	27.38 19	OCS	100	11.00
269	MATH URA	Farah	Sanaura	77.70 98	27.31	OCS	100	19.00
270	MATH URA	Mathura	Maholi	77.65 27	27.46 79	Next to OCS Block	100	15.00
271	MATH URA	Govardhan	Sakarwa	77.44 25	27.51 52	Next to OCS Block	100	12.00
272	MATH URA	Chaumuhan	Akbarpur	77.57 19	27.65 68	Next to OCS Block	100	14.00
273	MEER UT	Meerut	Gagaul	77.70 9	28.9	OCS	100	31.00
274	MEER UT	Meerut Urban	Meerut (M Corp.)	77.70 9	28.95 34	Urban Shallow	100	29.00
275	MEER UT	Meerut Urban	Meerut (M Corp.)	77.72 46	29.01 4	Urban Shallow	100	28.00
276	MEER UT	Sarurpur	Dahar	77.53 51	29.14 06	Next to OCS Block	100	23.00
277	MEER UT	Meerut Urban	Meerut (M Corp.)	77.64 97	28.92 41	Urban Shallow	100	25.00
278	MEER UT	Meerut Urban	Meerut (CB)	77.70 96	29.06 33	Urban Shallow	100	23.00
279	MEER UT	Meerut Urban	Meerut (M Corp.)	77.65 9	28.98 91	Urban Shallow	100	23.00
280	MEER UT	Machhra	Paswara	77.90 74	28.91 72	OCS	100	23.00
281	MEER UT	Parichhatgar h	Chitwana Sherpur	77.98 74	28.97 95	OCS	100	20.00
282	MEER UT	Jani	Siwal Khas	77.53 71	28.93 31	Next to OCS Block	100	18.00
283	MEER UT	Mawana Kalan	Nagla Hareroo	77.86 08	29.16 16	OCS	100	20.00
284	MEER UT	Sardhana	Khawajaha npur- Kushawali	77.64 44	29.18 63	Next to OCS Block	100	19.00
285	MEER UT	Rohta	Jatpura	77.57 42	29.04 28	Next to OCS Block	100	15.00
286	MEER UT	Hastinapur	Hastinapur Pandwan	78.02 12	29.15 59	OCS	100	15.00

287	MIRZ APUR	Sikhar	Pachraon	82.81 03	25.15 67	OCS	100	20.00
288	MIRZ APUR	Chanbey	Sindhuria	82.37 13	25.16 68	OCS	100	19.00
289	MIRZ APUR	City	Mirzapur- cum- Vindhyach al (NPP)	82.57 37	25.12 38	OCS	100	16.00
290	MIRZ APUR	Majhawan	Rama Pur	82.72 78	25.22 31	OCS	100	15.00
291	MIRZ APUR	Kon	Rakka Bhual	82.53 66	25.20 1	OCS	100	13.00
292	MORA DABA D	Bilari	Allapur Urf Rampur	78.85 99	28.56 45	OCS	100	28.00
293	MORA DABA D	Moradabad Urban	Pakbara (CT)	78.69 47	28.82 93	Urban Shallow	100	23.00
294	MORA DABA D	Moradabad Urban	Moradabad (M Corp.)	78.73 1	28.88 96	Urban Shallow	100	19.00
295	MORA DABA D	Moradabad Urban	Moradabad (M Corp.)	78.74 87	28.83 89	Urban Shallow	100	19.00
296	MORA DABA D	Kundarki (Dengapur)	Laither	78.76 66	28.71 68	OCS	100	22.00
297	MORA DABA D	Chhajlet	Mannagar Urf Kond	78.64 18	29.04 18	OCS	100	16.00
298	MORA DABA D	Moradabad Urban	Moradabad (M Corp.)	78.77 78	28.84 14	Urban Shallow	100	19.00
299	MORA DABA D	Dilari	Mahmood pur Lal	78.77 06	29.04 13	OCS	100	16.00
300	MORA DABA D	Moradabad	Ababakpur	78.76 55	28.90 78	OCS	100	18.00
301	MORA DABA D	Moradabad Urban	Moradabad (M Corp.)	78.76 93	28.81	Urban Shallow	100	19.00
302	MORA DABA D	Bhagatpur	Niwar Khas	78.88 54	28.97 65	OCS	100	16.00
303	MORA DABA D	Mundapande y	Samdi	78.90 31	28.78 72	OCS	100	17.00
304	MORA DABA D	Thakurdwar a	Karnabala Jabti	78.77 87	29.17 81	Next to OCS Block	100	13.00
305	MUZA FFAR NAGA R	Shahpur	Shahpur	77.55 88	29.35 24	OCS	100	23.00
306	MUZA FFAR NAGA R	Bhaghara	Karwara	77.58 37	29.41 92	OCS	100	29.00
307	MUZA FFAR	Muzaffarnag ar	Bajheri	77.71 43	29.50 57	OCS	100	26.00

	NAGA R							
308	MUZA FFAR NAGA R	Khatauli	Ladpur	77.76 19	29.28 94	Next to OCS Block	100	23.00
309	MUZA FFAR NAGA R	Charthawal	Nagla Rai	77.57 4	29.55 85	OCS	100	15.00
310	MUZA FFAR NAGA R	Morna	Yusufpur	77.89 52	29.48 04	Next to OCS Block	100	17.00
311	MUZA FFAR NAGA R	Jansath	Mujhera	77.94 59	29.30 95	Next to OCS Block	100	15.00
312	MUZA FFAR NAGA R	Purqaji	Jhabarpur	77.90 58	29.64 76	Next to OCS Block	100	10.00
313	PRAT APGA RH	Mangaraura	Chak Ramchand rapur	82.07 97	26.00 55	OCS	100	19.00
314	PRAT APGA RH	Sadar	Chakvan Tod	81.96 4	25.91 57	OCS	100	19.00
315	PRAT APGA RH	Sandwa Chandika	Bajhan	81.85 98	26.01 09	OCS	100	20.00
316	PRAT APGA RH	Lakshamanp ur	Dulhepur	81.80 35	25.90 79	OCS	100	19.00
317	PRAT APGA RH	Patti	Dhuti	82.17 82	25.93 36	OCS	100	18.00
318	PRAT APGA RH	Kunda	Bainti Uparhar	81.49 66	25.68 08	Next to OCS Block	100	19.00
319	PRAT APGA RH	Gaura	Thariya	82.07 51	25.74 13	OCS	100	17.00
320	PRAT APGA RH	Mandhata	Beerapur Bhoj	81.85 69	25.77 1	OCS	100	23.00
321	PRAT APGA RH	Shivgarh1	Mishrudee npur	82.08 95	25.84 94	OCS	100	15.00
322	PRAT APGA RH	Aspur Deosara	Bikram Patti	82.29 1	25.94 24	OCS	100	15.00
323	PRAT APGA RH	Baba Belkhar Nath Dham	Mangarh	81.51 69	25.79 31	OCS	100	17.00
324	PRAT APGA RH	Lalganj3	Sarai Sangrams ingh	81.56 74	25.89 8	OCS	100	16.00
325	PRAT APGA RH	Rampur- Sangramgar g	Medhawan	81.64 18	25.95 92	OCS	100	15.00

326	PRAY AGRA J	Bahadurpur1	Jirat Jamuni Gairabad	82.00 99	25.35 99	OCS	100	22.00
327	PRAY AGRA J	Saidabad	Dhudehri	82.10 92	25.40 51	OCS	100	19.00
328	PRAY AGRA J	PRAYAGR AJ Urban	Chak Hariharban	81.92 27	25.42 58	Urban Shallow	100	18.00
329	PRAY AGRA J	PRAYAGR AJ Urban	Allahabad (CB)	81.86 49	25.40 25	Urban Shallow	100	18.00
330	PRAY AGRA J	Chaka	Numaiya	81.76 54	25.38 58	OCS	100	19.00
331	PRAY AGRA J	PRAYAGR AJ Urban	Allahabad (M Corp. + OG)	81.82 18	25.44 43	Urban Shallow	100	18.00
332	PRAY AGRA J	PRAYAGR AJ Urban	Allahabad (M Corp. + OG)	81.77 29	25.44 24	Urban Shallow	100	19.00
333	PRAY AGRA J	Holagarh	Chaubara	81.77 67	25.68 36	OCS	100	21.00
334	PRAY AGRA J	Baharia	Chak Sulatan Urf Newada	81.97 77	25.61 12	OCS	100	17.00
335	PRAY AGRA J	Mauaima	Mirzapur Abubakarpur	81.89 04	25.68	OCS	100	18.00
336	PRAY AGRA J	Phulpur1	Bhamae Husamganj	82.08 3	25.58 39	Next to OCS Block	100	16.00
337	PRAY AGRA J	Handia	Jagua Sodha	82.21 82	25.33 97	Next to OCS Block	100	15.00
338	PRAY AGRA J	Dhanupur	Kunvarpur	82.19 57	25.44 58	OCS	100	15.00
339	PRAY AGRA J	PRAYAGR AJ Urban	Allahabad (M Corp. + OG)	81.86 47	25.47 42	Urban Shallow	100	15.00
340	PRAY AGRA J	Pratappur	Katehari	82.21 83	25.52 29	OCS	100	12.00
341	RAIBA RELI	Unchahar	Uncha Har Dehat	81.28 35	25.90 84	Next to OCS Block	100	18.00
342	RAMP UR	Bilaspur	Mubarkpur	79.28 44	28.87 08	Next to OCS Block	100	21.00
343	RAMP UR	Milak	Duli Chandpur	79.17 03	28.71 24	Next to OCS Block	100	19.00
344	RAMP UR	Chamrauwa	Durgu Nagla	79.06 13	28.75 56	OCS	100	16.00
345	RAMP UR	Shahabad2	Shahabad (NP)	78.99 98	28.57 62	OCS	100	15.00
346	RAMP UR	Saur	Aglaga	79.06 75	29.01 88	OCS	100	16.00
347	RAMP UR	Said Nagar	Jagatpur	79.04 01	28.87 2	OCS	100	16.00
348	SAHA	Gangoh	Dudhla	77.24	29.73	OCS	100	21.00

	RANP UR			97	17			
349	SAHA RANP UR	Punwarka	Asanwali	77.61 5	30.02 26	Next to OCS Block	100	38.00
350	SAHA RANP UR	Ballia Kheri	Saharanpur (M Corp.)	77.54 48	29.93 43	OCS	100	33.00
351	SAHA RANP UR	Nakur	Meerpur	77.26 27	29.92 99	OCS	100	23.00
352	SAHA RANP UR	Nagal	Tajpur	77.66 48	29.81 15	OCS	100	18.00
353	SAHA RANP UR	Deoband	Fatehpur Urf Sanpla Divara	77.71 46	29.67 41	OCS	100	15.00
354	SAHA RANP UR	Rampur Maniharan	Mundi Kheri	77.49 81	29.80 68	OCS	100	14.00
355	SAHA RANP UR	Sadhauli Kadeem	Mirzapur Pole	77.62 13	30.26 09	OCS	100	14.00
356	SAHA RANP UR	Muzaffaraba d	Janipur	77.75 9	30.16 15	OCS	100	15.00
357	SAHA RANP UR	Sarsawa	Meerpur Sitapur	77.42 75	30.05 45	OCS	100	12.00
358	SAHA RANP UR	Nanauta	Mora	77.48 41	29.69 67	OCS	100	13.00
359	SAMB HAL	Sambhal	Baripur Bhamraua	78.61 47	28.63 79	OCS	100	31.00
360	SAMB HAL	Asmoli	Chandbar	78.53 59	28.74 16	OCS	100	28.00
361	SAMB HAL	Pawansa	Sherpur	78.55 74	28.51 82	OCS	100	35.00
362	SAMB HAL	Baniakhera	Maulagarh	78.75 47	28.45 81	OCS	100	28.00
363	SAMB HAL	Bahjoi	Fatehpur Sharif Nagar	78.59 2	28.40 16	OCS	100	29.00
364	SAMB HAL	Janawai	Jhukera	78.53 4	28.22 41	OCS	100	24.00
365	SAMB HAL	Gunnaur	Kail	78.46 92	28.28 69	OCS	100	27.00
366	SAMB HAL	Rajpura2	Jahanpur	78.38 75	28.38 93	Next to OCS Block	100	22.00
367	SANT RAVID AS NAGA R	Bhadohi	Dhaskari	82.59 52	25.36 32	OCS	100	18.00
368	SANT RAVID AS NAGA R	Deegh	Sherpur Urf Vijalepur	82.34 87	25.29 24	OCS	100	18.00
369	SANT RAVID	Suriyawan	Bisunpur	82.45 33	25.43 81	OCS	100	8.00

	AS NAGA R							
370	SANT RAVID AS NAGA R	Aurai	Chak Bhawani	82.56 34	25.27 11	OCS	100	17.00
371	SANT RAVID AS NAGA R	Gyanpur	Devajitpur	82.43 46	25.34 32	OCS	100	15.00
372	SANT RAVID AS NAGA R	Abhauli	Lokmanpu r	82.36 58	25.39 82	OCS	100	12.00
373	SHAM LI	Shamli	Kudana	77.35 32	29.43 92	OCS	100	36.00
374	SHAM LI	Kairana	Bhura	77.19 1	29.44 85	OCS	100	25.00
375	SHAM LI	Un	Behda	77.21 53	29.58 62	OCS	100	23.00
376	SHAM LI	Thana Bhawan	Mant Manti	77.38 78	29.59 55	OCS	100	16.00
377	VARA NASI	Harahua	Gahani	82.94 05	25.42 08	OCS	100	20.00
378	VARA NASI	Araziline	Birbhanpur (CT)	82.83 87	25.26 89	OCS	100	17.00
379	VARA NASI	Pindra	Bhurkunda	82.87 27	25.49 61	OCS	100	16.00
380	VARA NASI	Sevapuri	Ramdih	82.75 99	25.33 52	OCS	100	16.00
381	VARA NASI	Kashi Vidyapith	Amara Khaira Chak (CT)	82.94 95	25.24 75	OCS	100	16.00
382	VARA NASI	Cholapur	Parana Patti	83.04 07	25.50 38	Next to OCS Block	100	15.00
383	Varana si	Varanasi Urban	Varanasi (M Corp.)	82.95 51	25.36 17	Urban Shallow	100	14.00
384	Varana si	Varanasi Urban	Varanasi (M Corp.)	83.01 64	25.36 95	Urban Shallow	100	13.00
385	Varana si	Varanasi Urban	Varanasi (M Corp.)	82.99 17	25.28 21	Urban Shallow	100	13.00
386	VARA NASI	Chiraigaon	Tofapur	83.09 51	25.38 44	OCS	100	13.00
387	Varana si	Varanasi Urban	Varanasi (M Corp.)	83.01 89	25.33 51	Urban Shallow	100	13.00
388	VARA NASI	Baragaon2	Kharawan	82.76 82	25.44 97	OCS	100	13.00
389	Varana si	Varanasi Urban	Varanasi (M Corp.)	83.00 04	25.31 27	Urban Shallow	100	12.00
UP PZ BOQ 3								

S_No_	District	Assessment_unit	Name_of_Village	Longitude	Latitude	Priority_areaif_o ther_than_OCS_	Proposed_Depth	Tentative_depth_ of_install ation_of DWLR_ m_
1	AGRA	Agra Urban	Agra (M Corp.)	78.05 59	27.15 58	Urban Deep	150	50.00
2	AGRA	Agra Urban	Agra (M Corp.)	78.01 93	27.18 7	Urban Deep	150	47.00
3	AGRA	Agra Urban	Agra (CB)	78.05 09	27.22 06	Urban Deep	150	44.00
4	AGRA	Agra Urban	Agra (M Corp.)	78.00 35	27.15 9	Urban Deep	150	46.00
5	AGRA	Agra Urban	Agra (M Corp.)	77.97 1	27.21 65	Urban Deep	150	33.00

UP PZ BOQ 4

S_No_	District	Assessment_unit	Name_of_Village	Longitude	Latitude	Priority_areaif_o ther_than_OCS_	Proposed_Depth	Tentative_depth_ of_install ation_of DWLR_ m_
1	ALIGARH	Aligarh Urban	Aligarh (M Corp.)	78.07 35	27.89 33	Urban Deep	250	36.00
2	ALIGARH	Aligarh Urban	Aligarh (M Corp.)	78.06 14	27.86 97	Urban Deep	250	37.00
3	ALIGARH	Aligarh Urban	Sarsaul (CT)	78.04 48	27.91 23	Urban Deep	250	35.00
4	Bareilly	Bareilly Urban	Bareilly (M Corp. + OG)	79.36 19	28.42 4	Urban Deep	250	30.00
5	Bareilly	Bareilly Urban	Bareilly (M Corp. + OG)	79.43 85	28.41 84	Urban Deep	250	29.00
6	Bareilly	Bareilly Urban	Bareilly (M Corp. + OG)	79.45 41	28.37 92	Urban Deep	250	29.00
7	GHAZIABAD	Ghaziabad Urban	Ghaziabad (M Corp.)	77.34 55	28.68 74	Urban Deep	250	27.00
8	GHAZIABAD	Ghaziabad Urban	Noida (CT)	77.34 34	28.65 16	Urban Deep	250	28.00
9	GHAZIABAD	Ghaziabad Urban	Ghaziabad (M Corp.)	77.40 9	28.66 83	Urban Deep	250	28.00
10	KANPUR NAGAR	Kanpur Urban	Kanpur (M Corp. + OG)	80.44 08	26.39 12	Urban Deep	250	15.00
11	KANPUR NAGAR	Kanpur Urban	Kanpur (CB)	80.36 98	26.42 53	Urban Deep	250	15.00
12	KANPUR NAGAR	Kanpur Urban	Kanpur (M Corp. + OG)	80.28 27	26.48 94	Urban Deep	250	15.00
13	LUCKNOW	Lucknow Urban	Lucknow (M Corp.)	80.92 33	26.83 59	Urban Deep	250	19.00

14	LUCK NOW	Lucknow Urban	Lucknow (M Corp.)	81.03 52	26.89 11	Urban Deep	250	18.00
15	LUCK NOW	Lucknow Urban	Lucknow (M Corp.)	80.94 64	26.92 48	Urban Deep	250	18.00
16	Meerut	Meerut Urban	Meerut (M Corp.)	77.72 46	29.01 4	Urban Deep	250	28.00
17	Meerut	Meerut Urban	Meerut (M Corp.)	77.64 97	28.92 41	Urban Deep	250	25.00
18	Meerut	Meerut Urban	Meerut (CB)	77.70 96	29.06 33	Urban Deep	250	23.00
19	MORA DABA D	Moradabad Urban	Pakbara (CT)	78.69 47	28.82 93	Urban Deep	250	23.00
20	MORA DABA D	Moradabad Urban	Moradabad (M Corp.)	78.73 1	28.88 96	Urban Deep	250	19.00
21	MORA DABA D	Moradabad Urban	Moradabad (M Corp.)	78.74 87	28.83 89	Urban Deep	250	19.00
22	PRAY AGRA J	PRAYAGR AJ Urban	Chak Hariharban	81.92 27	25.42 58	Urban Deep	250	18.00
23	PRAY AGRA J	PRAYAGR AJ Urban	Allahabad (CB)	81.86 49	25.40 25	Urban Deep	250	18.00
24	PRAY AGRA J	PRAYAGR AJ Urban	Allahabad (M Corp. + OG)	81.82 18	25.44 43	Urban Deep	250	18.00
25	PRAY AGRA J	PRAYAGR AJ Urban	Allahabad (M Corp. + OG)	81.77 29	25.44 24	Urban Deep	250	19.00
26	PRAY AGRA J	PRAYAGR AJ Urban	Allahabad (M Corp. + OG)	81.86 47	25.47 42	Urban Deep	250	15.00
27	Varanasi	Varanasi Urban	Varanasi (M Corp.)	82.95 51	25.36 17	Urban Deep	250	14.00
28	Varanasi	Varanasi Urban	Varanasi (M Corp.)	83.01 64	25.36 95	Urban Deep	250	13.00
29	Varanasi	Varanasi Urban	Varanasi (M Corp.)	82.99 17	25.28 21	Urban Deep	250	13.00
30	Varanasi	Varanasi Urban	Varanasi (M Corp.)	83.01 89	25.33 51	Urban Deep	250	13.00
31	Varanasi	Varanasi Urban	Varanasi (M Corp.)	83.00 04	25.31 27	Urban Deep	250	12.00

UP PZ BOQ 5

S_No_	Distric t	Assessment _unit	Name_of_ Village	Long itude	Latit ude	Priority_areaif_o ther_than_OCS_	Propose d_Depth	Tentative _depth__ of_install ation_of _DWLR_ _m_
1	ALIGA RH	Aligarh Urban	Asadpur Kayam	78.10 62	27.87 9	Urban Deep	350	37.00

2	ALIGARH	Aligarh Urban	Aligarh (M Corp.)	78.0918	27.9121	Urban Deep	350	35.00
3	Bareilly	Bareilly Urban	Bareilly (M Corp. + OG)	79.452	28.3283	Urban Deep	350	29.00
4	Bareilly	Bareilly Urban	Bareilly (M Corp. + OG)	79.4183	28.3885	Urban Deep	350	29.00
5	GHAZIABAD	Ghaziabad Urban	Ghaziabad (M Corp.)	77.4898	28.659	Urban Deep	350	26.00
6	GHAZIABAD	Ghaziabad Urban	Ghaziabad (M Corp.)	77.4761	28.704	Urban Deep	350	26.00
7	KANPUR NAGAR	Kanpur Urban	Kanpur (M Corp. + OG)	80.4139	26.3703	Urban Deep	350	15.00
8	KANPUR NAGAR	Kanpur Urban	Kanpur (M Corp. + OG)	80.3262	26.3993	Urban Deep	350	15.00
9	LUCKNOW	Lucknow Urban	Lucknow (M Corp.)	80.9178	26.7757	Urban Deep	350	19.00
10	LUCKNOW	Lucknow Urban	Sarsawan (CT)	80.9896	26.8015	Urban Deep	350	19.00
11	Meerut	Meerut Urban	Meerut (M Corp.)	77.709	28.9534	Urban Deep	350	29.00
12	Meerut	Meerut Urban	Meerut (M Corp.)	77.659	28.9891	Urban Deep	350	23.00
13	MORADABAD	Moradabad Urban	Moradabad (M Corp.)	78.7778	28.8414	Urban Deep	350	19.00
14	MORADABAD	Moradabad Urban	Moradabad (M Corp.)	78.7693	28.81	Urban Deep	350	19.00

OD PZ BOQ 1									
Sl. No.	District	Taluka/Mandal/Block/Firka	Village/Location	X (Longitude)	Y (Latitude)	Priority Area (OCS/Other Priority areas)	Proposed Depth (m)	Quality Probe	Depth of Installation of DWLR (mbgl)
1	Baleswar	Baleswar	Sunduri/Pir Dargha	86.93556	21.47528	Safe/Urban	80		40
2	Baleswar	Baleswar	Govt. Medical College/F M College	86.93222	21.49167	Safe/Urban	80	Quality Probe	40

3	Baleswar	Baleswar	Birla Tyre	86.91361	21.49333	Safe/Urban	80		40
4	Baleswar	Baleswar	F M University	86.89083	21.50583	Safe/Urban	80		40
5	Baleswar	Baleswar	Meghadamburu	86.90111	21.47806	Safe/Urban	80		40
6	Baleswar	Baleswar	Arad Bazar	86.92778	21.51083	Safe/Urban	80		40
7	Puri	Puri	Sanskrit University (Penthakata Road)	85.86167	19.8075	Safe/Urban	50		30
8	Puri	Puri	Light House (Swargadwara Road)	85.80639	19.79	Safe/Urban	50	Quality Probe	30
9	Puri	Puri	Hospital/ Jail	85.83083	19.81556	Safe/Urban	50	Quality Probe	30
10	Puri	Puri	Harekrushnapur/ Malatipatapur	85.83222	19.86722	Safe/Urban	50		30
11	Puri	Puri	Girala (Sipasurubili)	85.77167	19.81139	Safe/Urban	50		30
12	Jajpur	Korei	Badatrilochanpur	86.19944	20.86972	Semi-Critical	80		40
13	Jajpur	Korei	Korei	86.19611	20.9725	Semi-Critical	80		40
14	Jajpur	Korei	Andhari	86.11639	21.05861	Semi-Critical	80		40
15	Jajpur	Korei	Mukundapur	86.26111	21.03194	Semi-Critical	80		40

OD PZ BOQ 2

Sl. No	District	Taluka/Mandal/Block/Firka	Village/Location	X (Longitude)	Y (Latitude)	Priority Area (OCS/Other Priority areas)	Proposed Depth (m)	Quality Probe	Depth of Installation of DWLR (mbgl)
1	Baleswar	Baleswar	Chandipur	87.02167	21.4425	Safe/Urban	270	Quality Probe	40
2	Puri	Puri	Sanskrit University (Penthakata Road)	85.86167	19.8075	Safe/Urban	250	Quality Probe	30

OD PZ BOQ 3

Sl. No	District	Taluka/Mandal/Block/Firka	Village/Location	X (Longitude)	Y (Latitude)	Priority Area (OCS/Other Priority areas)	Proposed Depth (m)	Quality Probe	Depth of Installation of DWLR (mbgl)
1	Sambalpur	Sambalpur	Dhanupalli	83.99111	21.44806	Safe/Urban	100		40
2	Sambalpur	Sambalpur	Ainthapalli	83.98944	21.49167	Safe/Urban	100		40
3	Sambalpur	Sambalpur	Bareipalli	83.96306	21.49528	Safe/Urban	100		40
4	Sambalpur	Sambalpur	Sambalpur University	83.88639	21.48194	Safe/Urban	100		40
5	Sambalpur	Sambalpur	Dhankauda	84.00611	21.46833	Safe/Urban	100		40
6	Sambalpur	Sambalpur	Modipada	83.97028	21.47472	Safe/Urban	100		40

7	Sambalpur	Sambalpur	FCL, Remed Square	83.94417	21.50111	Safe/Urban	100		40
8	Sambalpur	Sambalpur	Ramchandra Nagar (Rengali)	84.05056	21.66222	Safe/Urban	100		40
9	Sambalpur	Sambalpur	Khairapali	84.03444	21.73806	Safe/Urban	100		40
10	Sambalpur	Sambalpur	Badamal	84.00861	21.81722	Safe/Urban	100		40
11	Sundargarh	Rourkela	Vedvyas Chowk	84.77722	22.23583	Safe/Urban	100		40
12	Sundargarh	Rourkela	Ispat General Hospital (Sector 19)	84.86778	22.2625	Safe/Urban	100		40
13	Sundargarh	Rourkela	OSAP High School	84.88806	22.23278	Safe/Urban	100		40
14	Sundargarh	Rourkela	Jalda Govt. High School	84.86028	22.18111	Safe/Urban	100		40
15	Sundargarh	Rourkela	Municipal College	84.84722	22.22167	Safe/Urban	100		40
16	Sundargarh	Rourkela	Kalokudar	84.75306	22.23972	Safe/Urban	100		40
17	Sundargarh	Rourkela	Kalunga	84.73861	22.21944	Safe/Urban	100		40

WB PZ BOQ 1										
Sl. No	District	Block/ Assessme nt unit	Name of Village/ Location	Lattit ude	Long itude	Propos ed Depth (m)	Sof t roc k/ Hard Roc k	Purpo se	Ten tativ e dept h of inst allat ion	Qualit y Probe

									of DW LR (m) *	
1	Alipurduar	Falakata	Beltali Bhandani	26.5 6729 4°	89.1 8319 3°	150	Soft rock	Seismic Areas	30.0	
2	Bankura	Bishnupur	Dwarika-Gossainpur	23.0 8817 °	87.3 8231 6°	150	Soft Rock	Semi-Critical	30.0	
3	Bankura	Raipur	Sarigari	22.7 5093 6°	86.8 9713 3°	150	Soft rock	Kangsabati Comm and Area	30.0	
4	Bankura	Sarenga	Kusumtikri	22.8 1183 7°	87.0 0542 1°	150	Soft rock	Kangsabati Comm and Area	30.0	
5	Bankura	Simlapal	Manipur	22.8 9678 4°	87.0 8706 7°	150	Soft rock	Kangsabati Comm and Area	30.0	
6	Bankura	Taldangra	Nachna	23.0 2000 0°	87.0 5260 3°	150	Soft rock	Kangsabati Comm and Area	30.0	
7	Bankura	Khatra	Khatra (Census town)	22.9 6843 4°	86.8 5439 5°	150	Soft rock	Kangsabati Comm and Area	30.0	
8	Bankura	Hirabund	Mosiara	23.0 4090 6°	86.7 7672 1°	150	Soft rock	Kangsabati Comm and Area	30.0	
9	Bankura	Onda	Karra	23.1 5517 3°	87.1 5596 2°	150	Soft rock	Kangsabati Comm and Area	30.0	
10	Bankura	Sonamukhi	Kochdihi	23.2 8516 9°	87.3 7042 7°	150	Soft rock	Kangsabati Comm and Area	30.0	
11	Bankura	Bishnupur	Beliara	23.1 1862 0°	87.3 5085 3°	150	Soft rock	Kangsabati Comm and Area	30.0	

12	Bankura	Joypur	Salda	23.0 4265 5°	87.4 6592 3°	150	Soft roc k	Kangs abati Comm and Area	30.0	
13	Bankura	Kotulpur	Koalpara	22.9 6127 3°	87.5 9933 6°	150	Soft roc k	Kangs abati Comm and Area	30.0	
14	Birbhum	Murarai-II	Mitrapur	24.4 2383 5°	87.9 6043 4°	150	Soft Roc k	Semi- Critica l	30.0	
15	Birbhum	Murarai-II	Paikar	24.4 3545 3°	87.9 1139 9°	150	Soft Roc k	Semi- Critica l	30.0	
16	Birbhum	Illambazar	Tinor	23.6 6679 1°	87.4 9766 7°	150	Soft roc k	Myur akshi Comm and Area	30.0	
17	Birbhum	Bolpur-Sriniketan	Bolpur	23.6 7113 5°	87.6 9189 1°	150	Soft roc k	Myura kshi Comm and Area	30.0	
18	Birbhum	Nanoor	Bheter	23.6 3611 2°	87.8 6736 2°	150	Soft roc k	Myura kshi Comm and Area	30.0	
19	Birbhum	Labpur	Labpur (Census Town)	23.8 1575 4°	87.7 9845 2°	150	Soft roc k	Myura kshi Comm and Area	30.0	
20	Birbhum	Sainthiya	Salgaria	23.8 4124 7°	87.6 7111 7°	150	Soft roc k	Myura kshi Comm and Area	30.0	
21	Birbhum	Suri-II	Gangie	23.8 3536 3°	87.5 5690 1°	150	Soft roc k	Myura kshi Comm and Area	30.0	
22	Birbhum	Myureswar-II	Bandihat	23.9 3606 2°	87.8 1685 6°	150	Soft roc k	Myura kshi Comm and Area	30.0	
23	Birbhum	Myureswar-I	Kanachi	24.0 7364 3°	87.7 7518 1°	150	Soft roc k	Myura kshi Comm and Area	30.0	

24	Birbhum	Mohammad Bazar	Fullaipur	24.0 0222 2°	87.5 4701 4°	150	Soft rock/ Hard rock	Myura kshi Comm and Area	30.0	
25	Birbhum	Rampurhat-II	Margram	24.1 4860 1°	87.8 4282 5°	150	Soft rock	Myura kshi Comm and Area	30.0	
26	Birbhum	Nalhati-II	Lohapur	24.3 0090 4°	87.9 6405 4°	150	Soft rock	Myura kshi Comm and Area	30.0	
27	Cooch Behar	Coochbehar II	Cooch Behar	26.3 3138 0°	89.4 4775 8°	150	Soft Rock	Urban Areas	30.0	
28	Howrah	Uluberia II	Abhirampur	22.4 8606 2°	88.0 2276 8°	150	Soft Rock	Industr ial areas	30.0	
29	Howrah	Uluberia II	Dashbhan ga	22.5 0422 3°	88.1 3883 6°	150	Soft Rock	Industr ial areas	30.0	
30	Howrah	Sankrail	Kanyamo ni	22.5 2923 0°	88.2 0592 4°	150	Soft Rock	Industr ial areas	30.0	
31	Howrah	Domjur	Jaychandi tala	22.6 3229 3°	88.2 4504 3°	150	Soft Rock	Industr ial areas	30.0	
32	Howrah	Bally Jagachha	Shibpur Urban Area (Under KMDA)	22.5 7121 6°	88.3 1089 1°	150	Soft Rock	Industr ial areas	30.0	
33	Hugli	Goghat-I	Gobindap ur	22.9 1762 5°	87.7 3355 5°	150	Soft rock	Kangs abati Comm and Area	30.0	
34	Hugli	Goghat-II	Paschim Amarpur	22.9 1237 1°	87.6 4943 9°	150	Soft rock	Kangs abati Comm and Area	30.0	
35	Jalpaiguri	Jalpaiguri	Kharia	26.4 9445 9°	88.6 8991 5°	150	Soft rock	Teesta/ Mahan anda Canal Comm and Area	30.0	
36	Malda	English Bazar	Malda	25.0 0813	88.1 4143	150	Soft Roc	Urban Areas	30.0	

				6°	7°		k			
37	Murshidabad	Barwan	Barwan	23.9 2853 °	87.9 3459 8°	150	Soft Roc k	Semi- Critica l	45.0	
38	Murshidabad	Barwan	Panch Thupi	23.8 8825 3°	87.9 8857 3°	150	Soft Roc k	Semi- Critica l	45.0	
39	Murshidabad	Bhagawa ngola-I	Mahisasth ali	24.3 2761 6°	88.3 1676 3°	150	Soft Roc k	Semi- Critica l	45.0	
40	Murshidabad	Bhagawa ngola-II	Nasipur	24.3 0781 °	88.3 618°	150	Soft Roc k	Semi- Critica l	45.0	
41	Murshidabad	Kandi	Mahaland i	24.0 7345 1°	88.1 2338 6°	150	Soft Roc k	Semi- Critica l	45.0	
42	Murshidabad	Khargram	Nagar	24.0 9146 °	87.9 8978 4°	150	Soft Roc k	Semi- Critica l	45.0	
43	Murshidabad	Khargram	Khargram	24.0 8456 8°	87.9 8728 2°	150	Soft Roc k	Semi- Critica l	45.0	
44	Murshidabad	Lalgola	Bayra	24.4 3286 9°	88.2 0817 7°	150	Soft Roc k	Semi- Critica l	45.0	
45	Murshidabad	Lalgola	Diar Fatepur	24.3 6297 7°	88.2 8747 7°	150	Soft Roc k	Semi- Critica l	45.0	
46	Murshidabad	Baharampur	Baharampur	24.0 8982 9°	88.2 7066 2°	150	Soft Roc k	Urban Areas	45.0	
47	Nadia	Hanskhali	Jaypur	23.3 5682 3°	88.5 5152 3°	150	Soft Roc k	Semi- Critica l	30.0	
48	Nadia	Krishnana gar I	Krishnana gar	23.4 0074 8°	88.5 0218 3°	150	Soft Roc k	Urban Areas	30.0	
49	Paschim Barddhaman	Durgapur	B-Zone (Under Municipal	23.5 6649 8°	87.3 1645 5°	150	Soft roc k	DVC Canal Comm and Area	45.0	
50	Paschim Barddhaman	Kanksa	Telipara	23.5 4274 5°	87.4 5790 3°	150	Soft roc k	DVC Canal Comm and Area	45.0	
51	Paschim Medinipur	Dantan-II	Sabra	21.9 8015 8°	87.3 9995 3°	150	Soft Roc k	Semi- Critica l	30.0	
52	Paschim Medinipur	Dantan-II	Turkakas hba	21.9 3739 9°	87.3 9599 2°	150	Soft Roc k	Semi- Critica l	30.0	

53	Paschim Medinipur	Dantan-II	Chauragram	21.9 6093 4°	87.4 6660 8°	150	Soft Roc k	Semi- Critica l	30.0	
54	Paschim Medinipur	Dantan-II	Renjura	21.9 0456 4°	87.4 2312 4°	150	Soft Roc k	Semi- Critica l	30.0	
55	Paschim Medinipur	Daspur-II	Chanipat	22.5 6621 4°	87.8 0427 7°	150	Soft Roc k	Semi- Critica l	30.0	
56	Paschim Medinipur	Daspur-II	Jot Ghanashyam	22.5 1745 4°	87.8 2784 9°	150	Soft Roc k	Semi- Critica l	30.0	
57	Paschim Medinipur	Debra	Dingal	22.3 4777 °	22.3 4777 °	150	Soft Roc k	Semi- Critica l	30.0	
58	Paschim Medinipur	Debra	Debra	22.3 6459 7°	87.5 5071 6°	150	Soft Roc k	Semi- Critica l	30.0	
59	Paschim Medinipur	Debra	Baragar	22.3 8336 6°	87.5 7155 °	150	Soft Roc k	Semi- Critica l	30.0	
60	Paschim Medinipur	Debra	Duan	22.3 6014 5°	87.5 8648 3°	150	Soft Roc k	Semi- Critica l	30.0	
61	Paschim Medinipur	Debra	Satyapur	22.4 6722 1°	87.5 7183 1°	150	Soft Roc k	Semi- Critica l	30.0	
62	Paschim Medinipur	Debra	Golgram	22.4 6891 5°	87.6 3148 1°	150	Soft Roc k	Semi- Critica l	30.0	
63	Paschim Medinipur	Debra	Jalimanda	22.3 6145 5°	87.5 0553 2°	150	Soft Roc k	Semi- Critica l	30.0	
64	Paschim Medinipur	Pingla	Maligram	22.2 7305 8°	87.6 4355 9°	150	Soft Roc k	Semi- Critica l	30.0	
65	Paschim Medinipur	Sabang	Adasimla	22.1 2818 9°	87.5 3513 5°	150	Soft Roc k	Semi- Critica l	30.0	
66	Paschim Medinipur	Sabang	Shitalda	22.1 6304 3°	87.6 6146 4°	150	Soft Roc k	Semi- Critica l	30.0	
67	Paschim Medinipur	Sabang	Sabang	22.1 7993 3°	87.5 9384 6°	150	Soft Roc k	Semi- Critica l	30.0	
68	Paschim Medinipur	Sabang	Mohar	22.1 6295 2°	87.6 8814 8°	150	Soft Roc k	Semi- Critica l	30.0	
69	Paschim Medinipur	Sabang	Bishnupur	22.1 3025 1°	87.6 5348 1°	150	Soft Roc k	Semi- Critica l	30.0	
70	Paschim Medinipur	Sabang	Bural	22.1 5799 9°	87.6 4597 1°	150	Soft Roc k	Semi- Critica l	30.0	

71	Paschim Medinipur	Kharagpur-I	Kharagpur	22.3 3555 3°	87.2 2447 3°	150	Soft Rock	Urban Areas	30.0	
72	Purba Barddhaman	Katwa-I	Sreekhandada	23.5 9748 °	88.0 7320 6°	150	Soft Rock	Semi-Critical	45.0	
73	Purba Barddhaman	Memari-II	Mandalgram	23.3 4388 °	88.0 8227 7°	150	Soft Rock	Semi-Critical	45.0	
74	Purba Barddhaman	Memari-II	Satgachhia	23.2 6252 1°	88.1 4020 5°	150	Soft Rock	Semi-Critical	45.0	
75	Purba Barddhaman	Mongalkote	Kaichar	23.5 3747 9°	88.0 0812 6°	150	Soft Rock	Semi-Critical	45.0	
76	Purba Barddhaman	Mongalkote	Purbba Gopalpur	23.5 2825 2°	88.0 4581 1°	150	Soft Rock	Semi-Critical	45.0	
77	Purba Barddhaman	Raina-I	Bantir	23.1 6191 8°	87.8 9521 6°	150	Soft Rock	Semi-Critical	45.0	
78	Purba Barddhaman	Raina-I	Rayna	23.1 0990 2°	87.8 6835 2°	150	Soft Rock	Semi-Critical	45.0	
79	Purba Barddhaman	Raina-I	Haripur	23.1 7340 4°	87.9 2949 6°	150	Soft Rock	Semi-Critical	45.0	
80	Purba Barddhaman	Raina-II	Uchalan	22.9 9545 2°	87.7 7788 3°	150	Soft Rock	Semi-Critical	45.0	
81	Purba Barddhaman	Raina-II	Chhota Bainan	22.9 9499 8°	87.8 5244 5°	150	Soft Rock	Semi-Critical	45.0	
82	Purba Barddhaman	Raina-II	Bara Bainan	23.0 0851 8°	87.9 3593 2°	150	Soft Rock	Semi-Critical	45.0	
83	Purba Barddhaman	Raina-II	Kamarhati	22.9 7991 9°	87.8 8980 9°	150	Soft Rock	Semi-Critical	45.0	
84	Purba Barddhaman	Ausgram-II	Premganja	23.4 7885 2°	87.5 4206 1°	150	Soft rock	DVC Canal Comm and Area	45.0	
85	Purba Barddhaman	Ausgram-I	Laxmiganj	23.4 8203 6°	87.7 1076 8°	150	Soft rock	DVC Canal Comm and Area	45.0	
86	Purba Barddhaman	Galsi-I	Sukdal (Census Town)	23.3 9760 1°	87.5 4691 7°	150	Soft rock	DVC Canal Comm and Area	45.0	
87	Purba Barddhaman	Galsi-II	Galsi	23.3 3064	87.6 8580	150	Soft rock	DVC Canal	45.0	

	man			3°	1°		k	Comm and Area		
88	Purba Barddha man	Bhatar	Dhandals a	23.3 9411 8°	87.8 1320 0°	150	Soft roc k	DVC Canal Comm and Area	45.0	
89	Purba Barddha man	Burdwan- I	Burdwan (Under Municipal	23.2 2815 5°	87.8 6106 8°	150	Soft roc k	DVC Canal Comm and Area	45.0	
90	Purba Barddha man	Burdwan- II	Saktigarh	23.1 9998 5°	87.9 7163 0°	150	Soft roc k	DVC Canal Comm and Area	45.0	
91	Purba Barddha man	Memari-II	Satgachia	23.2 5928 9°	88.1 5140 4°	150	Soft roc k	DVC Canal Comm and Area	45.0	
92	Purba Barddha man	Memari-I	Bahabpur	23.1 8948 2°	88.1 2669 1°	150	Soft roc k	DVC Canal Comm and Area	45.0	
93	Purba Barddha man	Manteswa r	Kusumgra m	23.3 8881 4°	88.1 3406 3°	150	Soft roc k	DVC Canal Comm and Area	45.0	
94	Purba Barddha man	Khandagh osh	Kule	23.1 6026 5°	87.7 4440 7°	150	Soft roc k	DVC Canal Comm and Area	45.0	
95	Purba Barddha man	Raina I	Palasan	23.0 6407 5°	87.8 5984 1°	150	Soft roc k	DVC Canal Comm and Area	45.0	
96	Purba Barddha man	Raina II	Madhabdi hi	23.0 6407 5°	87.8 5984 1°	150	Soft roc k	DVC Canal Comm and Area	45.0	
97	Purba Barddha man	Jamalpur	Dhuluk	23.0 9025 1°	88.0 4607 9°	150	Soft roc k	DVC Canal Comm and Area	45.0	
98	Purba Barddha man	Ketugram -I	Masundi	23.7 0380 7°	87.9 7634 9°	150	Soft roc k	DVC Canal Comm	45.0	

								and Area		
99	Purba Barddhaman	Ketugram -II	Gomai	23.700586°	88.063199°	150	Soft rock	DVC Canal Comm and Area	45.0	
100	Purba Barddhaman	Mangolko te	Mangalkot	23.522877°	87.903985°	150	Soft rock	DVC Canal Comm and Area	45.0	
101	Purba Barddhaman	Burdwan I	Bardhaman	23.232012°	87.861247°	150	Soft Rock	Urban Areas	45.0	
102	Purba Medinipur	Haldia	Haldia Township	22.052616°	88.114940°	150	Soft Rock	Industrial areas	45.0	with Salinity Probe
103	Purba Medinipur	Haldia	Haldia Township	22.031488°	88.064904°	150	Soft Rock	Industrial areas	45.0	with Salinity Probe
104	Uttar Dinajpur	Chopra	Dakshin Ariagaon	26.400788°	88.345836°	150	Soft rock	Teesta/ Mahananda Canal Comm and Area	30.0	

WB PZ BOQ 2

Sl. No	District	Block/ Assessme nt unit	Name of Village/ Location	Latti tude	Long itude	Propos ed Depth (m)	Sof t roc k/ Ha rd Roc k	Purpo se	Ten tative dept h of inst allat ion of DW LR (m) *	Qualit y Probe
1	Birbhum	Labhpur	Danrka	23.871504°	87.810788°	300	Soft Roc k	Semi-Critical	30.0	
2	Birbhum	Labhpur	Shekham pur	23.814566°	87.769041°	300	Soft Roc k	Semi-Critical	30.0	

3	Howrah	Uluberia II	Brindabonpur (Census Town)	22.501442°	88.090899°	300	Soft Rock	Industrial areas	30.0	
4	Howrah	Sankrail	Banipur	22.566470°	88.230795°	300	Soft Rock	Industrial areas	30.0	
5	Howrah	Bally Jagachha	Bally (Census Town)	22.649267°	88.338771°	300	Soft Rock	Industrial areas	30.0	
6	Kolkata Municipal Corporation	Kolkata Municipal Corporation	Kolkata	22.560753°	88.354227°	300	Soft Rock	Urban Areas	30.0	
7	Nadia	Nabadwip	Nabadwip	23.405164°	88.365945°	300	Soft Rock	Urban Areas	30.0	
8	North 24-Parganas	Barrackpore-II	Dangadihila	22.73988°	88.404264°	300	Soft Rock	Semi-Critical	30.0	
9	North 24-Parganas	Barrackpore-II	Surjyapur	22.751455°	88.418828°	300	Soft Rock	Semi-Critical	30.0	
10	Purba Medinipur	Sutahata	Sutahata	22.122746°	88.112060°	300	Soft Rock	Urban Areas	45.0	
11	Purba Medinipur	Ramnagar I	Digha	21.622503°	87.505947°	300	Soft Rock	Coastal areas	45.0	
12	Purba Medinipur	Ramnagar II	Talkatalia	21.685875°	87.600095°	300	Soft Rock	Coastal areas	45.0	
13	Purba Medinipur	Contai I	Doudpur	21.718344°	87.705015°	300	Soft Rock	Coastal areas	45.0	
14	Purba Medinipur	Contai II	Bamunia	21.747983°	87.808073°	300	Soft Rock	Coastal areas	45.0	
15	Purba Medinipur	Contai III	Sukunia	21.909616°	87.739386°	300	Soft Rock	Coastal areas	45.0	with Salinity Probe
16	Purba Medinipur	Khejuri II	Daulatpur	21.785273°	87.852366°	300	Soft Rock	Coastal areas	45.0	with Salinity Probe
17	Purba Medinipur	Haldia	Haldia Township	22.053274°	88.082889°	300	Soft Rock	Industrial areas	45.0	with Salinity Probe
18	South 24 Parganas	Magrahat - I	Rangilabadd	22.272606°	88.310557°	300	Soft Rock	Coastal areas	30.0	with Salinity Probe

19	South 24 Parganas	Jaynagar - II	Baishata	22.1 2978 6°	88.4 6805 9°	300	Soft Roc k	Coasta l areas	30.0	with Salini ty Probe
20	South 24 Parganas	Mandirbar zar	Moheshp ur	22.1 2303 7	88.3 6879 9	300	Soft Roc k	Coasta l areas	30.0	with Salini ty Probe
21	South 24 Parganas	Mandirbar zar	Madhabp ur	22.1 1483 7°	88.3 4422 7°	300	Soft Roc k	Coasta l areas	30.0	with Salini ty Probe
22	South 24 Parganas	Kultali	Balaharan ia	22.1 0810 1°	88.5 9635 7°	300	Soft Roc k	Coasta l areas	30.0	with Salini ty Probe
23	South 24 Parganas	Kulpi	Inayatpur	22.0 4183 2°	88.2 7701 6°	300	Soft Roc k	Coasta l areas	30.0	with Salini ty Probe
24	South 24 Parganas	Mathurap ur - I	Nalua	22.1 1655 8°	88.4 3936 7°	300	Soft Roc k	Coasta l areas	30.0	with Salini ty Probe
25	South 24 Parganas	Sagar	Kachubari a	21.8 3985 5°	88.1 3397 1°	300	Soft Roc k	Coasta l areas	30.0	with Salini ty Probe
26	South 24 Parganas	Patharprat ima	Dakshin Lakshmin arayanpur	21.7 6746 5°	88.3 4088 5°	300	Soft Roc k	Coasta l areas	30.0	with Salini ty Probe
27	South 24 Parganas	Namkhan a	Shibnagar Abad	21.7 2186 2°	88.2 4121 4°	300	Soft Roc k	Coasta l areas	30.0	with Salini ty Probe

WB PZ BOQ 3

Sl. No	District	Block/ Assessme nt unit	Name of Village/ Location	Latti tude	Long itude	Propos ed Depth (m)	Sof t roc k/ Ha rd Roc k	Purpo se	Ten tativ e dept h of inst allat ion of DW LR (m) *	Qualit y Probe
-------------------	-----------------	--	--	-----------------------	-----------------------	--	---	---------------------	--	-------------------------------

1	Alipurduar	Madarihat	Dhumchi para Tea Garden	26.7 5359 7°	89.2 3131 0°	150	Soft rock (Bouldery Formation)	Seismic Areas	30.0	
2	Alipurduar	Alipurduar-I	Uttar Simlabari	26.5 3821 2°	89.3 6759 3°	150	Soft rock (Bouldery Formation)	Seismic Areas	30.0	
3	Alipurduar	Kalchini	Raja Bhat Khawa	26.6 0813 3°	89.5 3200 3°	150	Soft rock (Bouldery Formation)	Seismic Areas	30.0	
4	Alipurduar	Alipurduar-II	Uttar Majid Khana	26.4 8875 8°	89.6 3719 8°	150	Soft rock (Bouldery Formation)	Seismic Areas	30.0	
5	Alipurduar	Kumargram	Kumargram	26.6 1024 7°	89.8 2937 9°	150	Soft rock (Bouldery Formation)	Seismic Areas	30.0	
6	Darjeeling	Matigara	Siliguri	26.7 1509 3°	88.3 9353 2°	150	Soft rock (Bouldery Formation)	Urban Areas	30.0	
7	Darjeeling	Matigara	Udaysing	26.7 6114	88.4 0404	150	Soft rock	Seismic	30.0	

				1°	0°		k (Bo uld ery For mat ion)	Areas		
8	Darjeeli ng	Naxalbari	Naxalbari	26.6 8217 0°	88.1 9987 5°	150	Soft roc k (Bo uld ery For mat ion)	Seismi c Areas	30.0	
9	Darjeeli ng	Kharibari	Kishordo ba	26.5 6157 4°	88.1 5594 5°	150	Soft roc k (Bo uld ery For mat ion)	Seismi c Areas	30.0	
10	Darjeeli ng	Phanside wa	Bhushibhi ta	26.6 2758 7°	88.3 4573 3°	150	Soft roc k (Bo uld ery For mat ion)	Seismi c Areas	30.0	
11	Darjeeli ng	Phanside wa	Luisipuku ri	26.6 2237 9°	88.3 7032 8°	150	Soft roc k (Bo uld ery For mat ion)	Teesta / Maha nanda Canal Comm and Area	30.0	
12	Jalpaigu ri	Mal	Dakshin Hanskhali	26.7 3680 5°	88.6 5811 3°	150	Soft roc k (Bo uld ery For mat ion)	Seismi c Areas	30.0	
13	Jalpaigur i	Metiali	Chalsa	26.8 7914 7°	88.7 9819 7°	150	Soft roc k (Bo	Seismi c Areas	30.0	

							uld ery For mat ion)			
14	Jalpaiguri	Nagrakata	Sulkapara	26.8 5658 3°	88.9 0789 4°	150	Soft roc k (Bo uld ery For mat ion)	Seismi c Areas	30.0	
15	Jalpaiguri	Dhupguri	Dakshin Khuttimar i	26.6 6342 8°	88.9 7725 9°	150	Soft roc k (Bo uld ery For mat ion)	Seismi c Areas	30.0	
16	Jalpaiguri	Rajganj	Chakiabhi ta (Census Town)	26.6 4976 3°	88.5 1555 6°	150	Soft roc k (Bo uld ery For mat ion)	Teesta/ Mahan anda Canal Comm and Area	30.0	
17	Jalpaiguri	Maynaguri	Dakshin Khagraba ri (Census Town)	26.5 5309 2°	88.8 3826 8°	150	Soft roc k (Bo uld ery For mat ion)	Teesta/ Mahan anda Canal Comm and Area	30.0	

WB PZ BOQ 4

Sl. No	District	Block/ Assessme nt unit	Name of Village/ Location	Latti tude	Long itude	Propos ed Depth (m)	Sof t roc k/ Ha rd Roc k	Purpo se	Ten tativ e dept h of inst allat ion of DW LR (m)	Qualit y Probe
-----------	----------	-------------------------------	---------------------------------	---------------	---------------	------------------------------	---	-------------	--	----------------------

									*	
1	Paschim Bardhaman	Durgapur	Durgapur	23.5 2027 2°	87.3 1192 6°	150	Hard rock	Urban Areas	30.0	
*Actual depth of installation of DWLR in proposed 149 PZ would be determined based on drilling result at the sites										

Note: The location above are Tentative and may be changed

SECTION-VIII

FORMATS FOR SUBMISSION OF DATA

SECTION-VIII

FORMATS FOR SUBMISSION OF DATA

Annexure A

LOGGING DATA (NATURAL GAMMA LOGGING)

Unique ID	
Location	
Block	
District	
Toposheet Number	
Latitude in Degree Decimal	
Longitude in Degree Decimal	
Site plan and RL(m amsl)	
Date/Year	
Depth Drilled (m bgl)	
Depth Logged (m bgl)	
Bore hole dia.	

Unique ID

Depth range (m bgl)		Thickness (m)	Natural Gamma counts (CPS)	Inferred Lithology	Ground water Quality
From	To				

Signature and stamp of Authorized signatory

LOGGING DATA (CALIPER LOGGING)

Unique ID	
Location	
Block	
District	
Toposheet Number	
Latitude in Degree Decimal	
Longitude in Degree Decimal	
Site plan and RL(m amsl)	
Date/Year	
Depth Drilled (m bgl)	
Depth Logged (m bgl)	
Bore hole dia.	

Unique ID

S.No.	Depth range (m bgl)		Thickness (m)	Borehole Diameter	Remarks
	From	To			

Signature and stamp of Authorized signatory

**PRELIMINARY YIELD TEST(PYT)
(IF SPECIFIED IN BOQ)**

Site name with coordinates				
Location details				
Block				
District & State				
Type of Well				Pumping well
Date of Test & Start time				
Diameter of well (mm)				
Discharge (lps)				
Measuring Point (m)				
SWL in m below measuring point				
Time since pump started (min) (t)	Time since stopping of pumping (min) (t')	Water level (m bmp)	Residual Drawdown RDD (m)	t/t'
Interval for Recording of data.				
1 minute interval upto 10 min				
2 minute interval upto 20 min				
1				
2				
3				
4				
5				
6				
7				
8				
9				
10				
12				
14				
16				
18				
20				
25				
30				
5 minute interval upto 50 min				
10 min recording upto 100 min				
20 min recording upto 200min				
50 min recording until 500 min				
100 min recording until 90% recuperation to Static water level.				

SLUG TEST DATA SHEET (IF SPECIFIED IN BOQ)

Well no: _____ Date of test _____

Location:

Administrative Block: _____ District: _____ State _____

Latitude (Degree Decimal) : _____ Longitude(Degree Decimal): _____ Toposheet no: _____

Well Details:

Type of Well: BW/TW Owner: Govt/Private. Well usage: Irrigation/Domestic Well status: In use/Abandoned

Geologic formation _____ Depth of the well: _____ (m). Diameter of Well : _____ (mm) Casing length _____ (m) Reported discharge _____ lps.

Alluvial area/Hard rock area: Zones tapped/Fractures encountered from _____ to _____ (m).

Test Reading

Measuring point (MP) _____ (m) Static WL _____ (m) Slug Quantity(Injection) _____ litre.

Time of start of test _____ Time of Completion of test _____ Length of test _____ (Minutes)

Results:**Analysis method**

Type of aquifer: Unconfined/Confined. Method used for Analysis: _____

Aquifer parameters:Transmissivity _____ m²/d and Hydraulic Conductivity (K) _____ m/d.

Name of personnel conducted test

Signature

Date

SLUG TEST - DATA SHEET (IF SPECIFIED IN BOQ)

Site name				
Latitude (Degree Decimal)				
Longitude (Degree Decimal)				
Block				
District & State				
Volume of Slug injected (litres)				
Diameter of well (mm)				
Date of Test				
Height of M.P (m.agl)				
SWL in m below measuring point (m)				
Time (min)	Time (sec)	Water level (H) in m	Change in Water Level (Ho) in m	H/Ho
1				
2				
3				
4				
5				
6				
7				
8				
9				
10				
12				
14				
16				
18				
20				
25				
30				
35				
40				
45				
50				
55				
60				
65				
70				
75				
80				
85				
90				
95				
100				

CONSOLIDATED STATEMENT OF SLUG TEST (IF SPECIFIED IN BOQ)

Sl.no	Village name	Lat	Long	Depth of well	Geological formation	K value (m/d)		
						Hvorslev method	Bouwer and Rice method	Cooper et al
1								
2								
3								
4								
5								
6								
7								
8								
9								
10								

WELL INVENTORY - DATA SHEET

Well no: _____

Date of inventory _____

Location :

Administrative Block: _____ District: _____ State _____

Latitude: _____ Longitude: _____ Toposheet no: _____

Name of the Watershed _____ Area of the Watershed _____ km²

Geologic formation _____

Type of Well: DW/DCB/BW* Owner: Govt/Pvt. Well usage: Irrigation/Domestic.

Depth of the well : _____ (m). Diameter of Well : _____ (mm)

Casing length/ Curbing depth (m _____ (m) Reported discharge _____ lps.

Weathering thickness) _____ m Fractures encountered from _____ to _____ (m).

Measuring point (MP) _____ (m) Static WL _____ (m) Type of Pump- Submersible/Centrifuge/JET Pump Capacity _____ (HP)

Hours of pumping _____ hrs/day. Number of pumping days _____ days /year. Total estimated draft _____ m³/year.

Cropping pattern _____

Command area of the well _____ ha.

Any other Salient feature : _____

Name of officer

GOVERNMENT OF INDIA
MINISTRY OF JAL SHAKTI
CENTRAL GROUND WATER BOARD

BASIC DATA REPORT

**BASIC DATA REPORT OF PIEZOMETER WELL
AT (Name of Village), (Name of block)
District / State**

**By
Agency**

Under overall supervision of

**(Name of region)
Regional HQ
Month/ year**

BASIC DATA REPORT OF PIEZOMETER WELL
AT (Name of Village), (Name of block)
District / State

CONTENTS

1. Location
2. Purpose of drilling
3. Drilling history
4. Geology
- 4.1 Sub surface geology
5. Geophysical logging
6. Well Assembly
7. Hydro-Chemistry

A. Plates

1. Site plan.
2. Litho log and Well designs
3. Gamma/ Caliper/Electrical log - Analog

Annexures

1. Drill time log

GOVERNMENT OF INDIA
MINISTRY OF JAL SHAKTI
CENTRAL GROUND WATER BOARD
(Name of region)
Regional HQ

1. **BASIC DATA REPORT**

LOCATION : --

BLOCK : ---

DISTRICT/ state : --

CO-ORDINATES : Long: A⁰ B' C" E
Lat: X⁰ Y' Z" N

SURVEY OF INDIA TOPO SHEET NO. :

BASIC DATA REPORT OF PIEZOMETER WELL
AT (Name of Village), (Name of block)
District / State

1. LOCATION

Give details of site, alongwith location approach

2. PURPOSE AND SCOPE

Describe the purpose and scope of ground water exploration

3. DRILLING HISTORY

Brief history of various activities and methods applied in carrying out ground water exploration. In respect of soft rock, depth at which fracture encountered and discharge measured during drilling of each fracture zone etc. to be furnished.

4. GEOLOGY

Give general geology of the area

4.1 SUB SURFACE GEOLOGY

Litholog

Lithology	Depth range (m)		Thickness (m)
	From	to	

Composite log

Lithology	Depth range (m)		Thickness (m)
	From	to	

5. ELECTRICAL/ NATURAL GAMMA LOGGING OF BOREHOLE

Alluvium Areas: Zones deciphered on the basis of Electrical/ Natural Gamma logging

S.No.	Depth range (m bgl)		Thickness (m)	Ground water Quality EC/(TDS)
	From	To		

Hard Rock Area : Weathered/Fractured Zones deciphered on the basis of Calliper logging

S.No.	Depth range (m bgl)		Thickness (m)	Borehole Diameter	Remarks
	From	To			

6. WELL ASSEMBLY

Well assembly of PIEZOMETER well

Depth range m (bgl)	Length (m)	Dia (mm)	Slot size(mm)	Description

7.0 CHEMICAL QUALITY OF GROUND WATER

Table: Results of chemical analysis of water samples

Water sample	Constituents										
	pH	EC micro mhos /cm at 25 ^o c	2 H CO ₃	Cl	NO ₃	F	Ca	Mg	Na	K	Total hardness as CaCO ₃
	Concentrations in mg/l										
Heavy metals											

8.0 WELL DIAGRAM

In respect of soft rock formation and soft boulder formation:-

Well diagram with details of final reamed dia, well assembly (blank and screen position) with assembly size and depth, gravel packing and its depth, cement sealing with depth, clay packing and depth, concrete platform and static water level.

In respect of hard rock formation:-

Well diagram with details of overburden drilling dia, casing pipe length, dia, naked well dia, fracture zone and it depth and it's depth, part assembly (blank/ screen position) cement sealing with depth, clay packing and depth, concrete platform and static water level.

SECTION-IX

DRAWINGS

Section-IX

ANNEXURE- N

SAMPLE DRAWING OF HOUSING PIPE (Top View) & WELL CAP

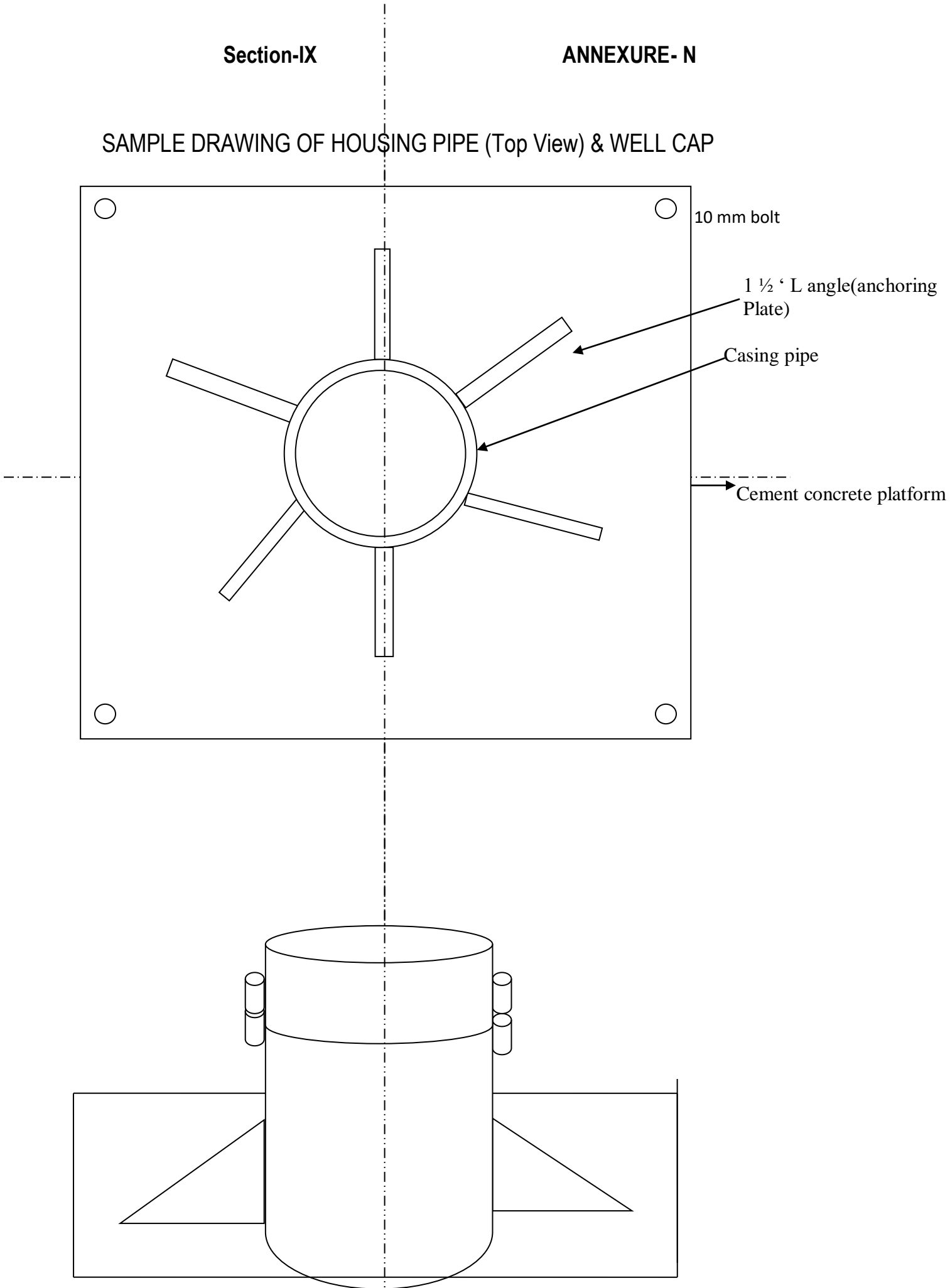

(SAMPLE DRAWINGS) Annexure-O

Well cap

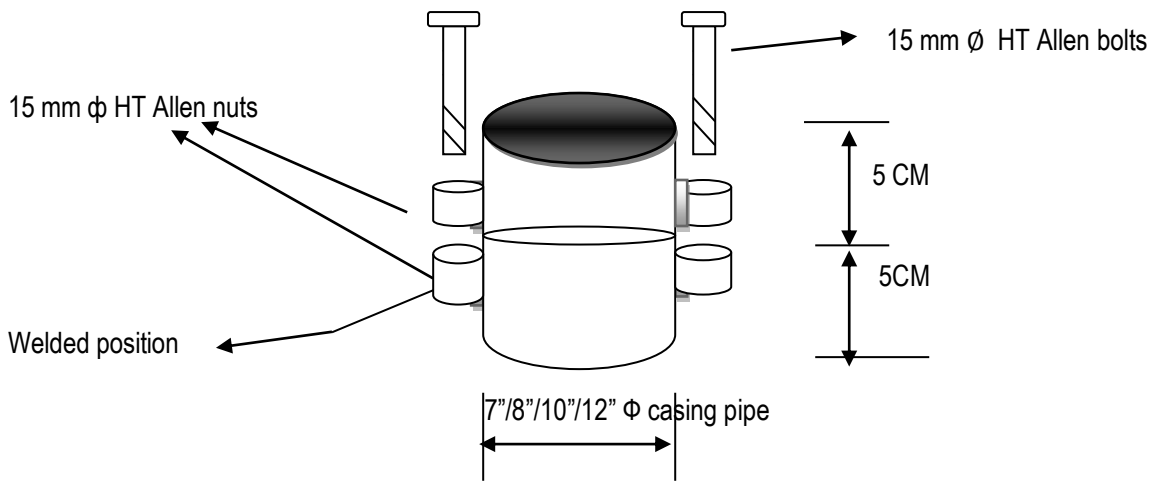

(SAMPLE DRAWINGS) Annexure- P

Cement concrete platform

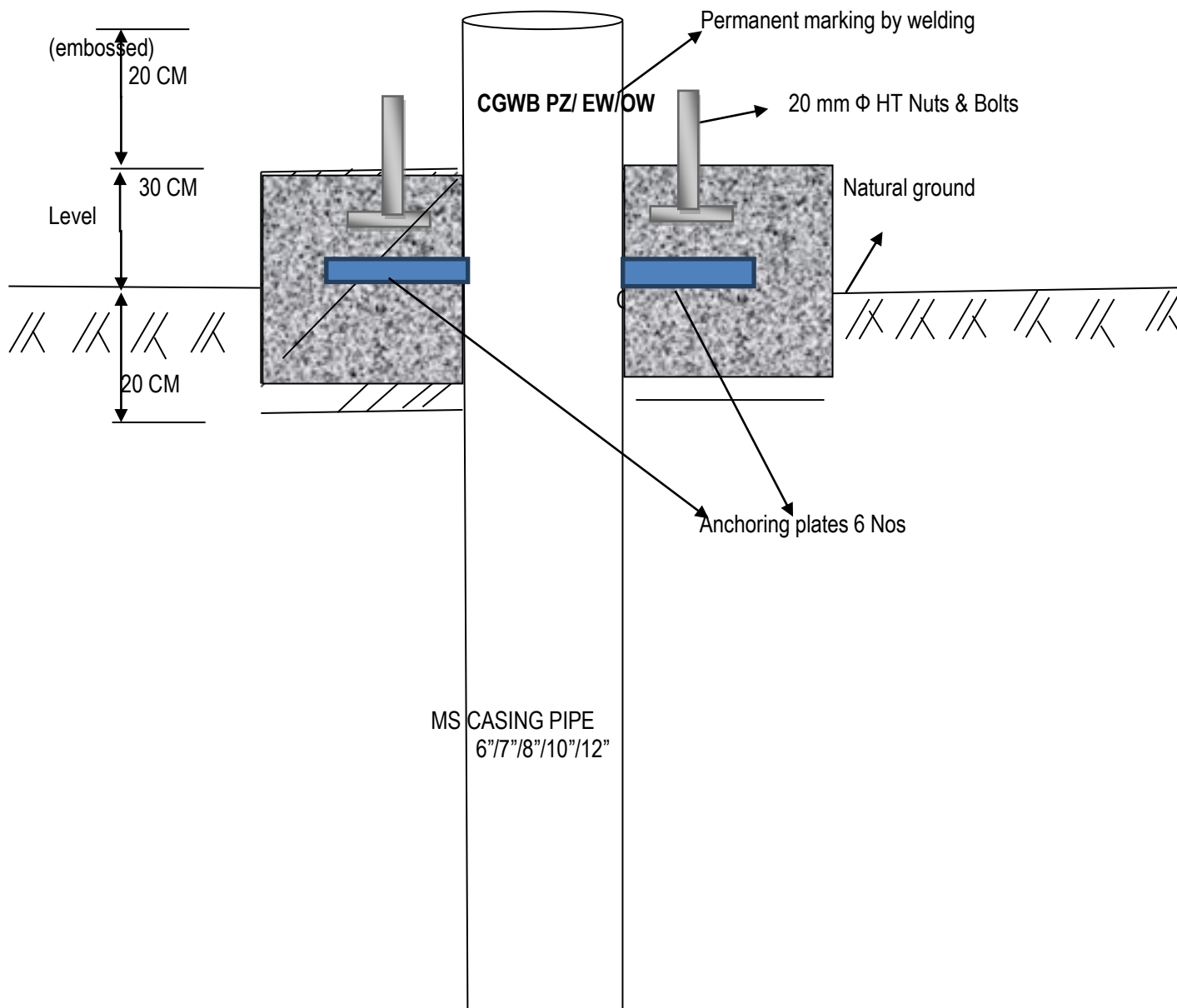

A cement/ concrete platform measuring 0.70 X 0.70 X 0.60 m (0.30 m above ground level and 0.30m below ground level) around the well casing is to be provided over which protection box is to be provided. The concrete mix ratio is 1:2:4

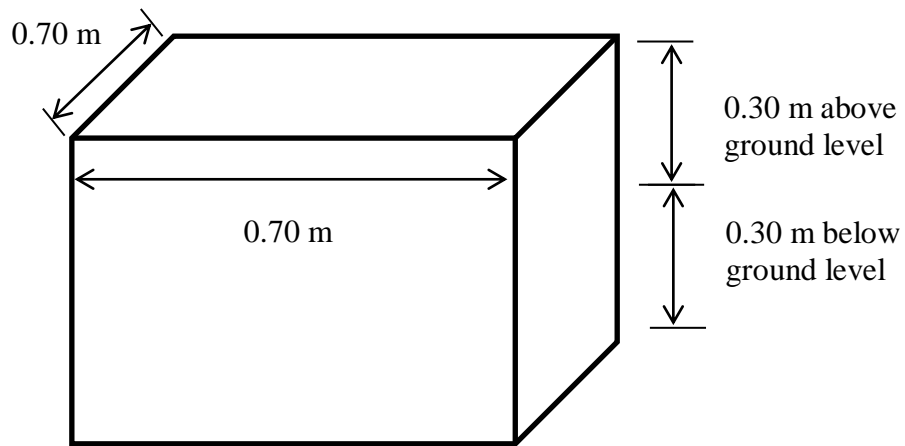



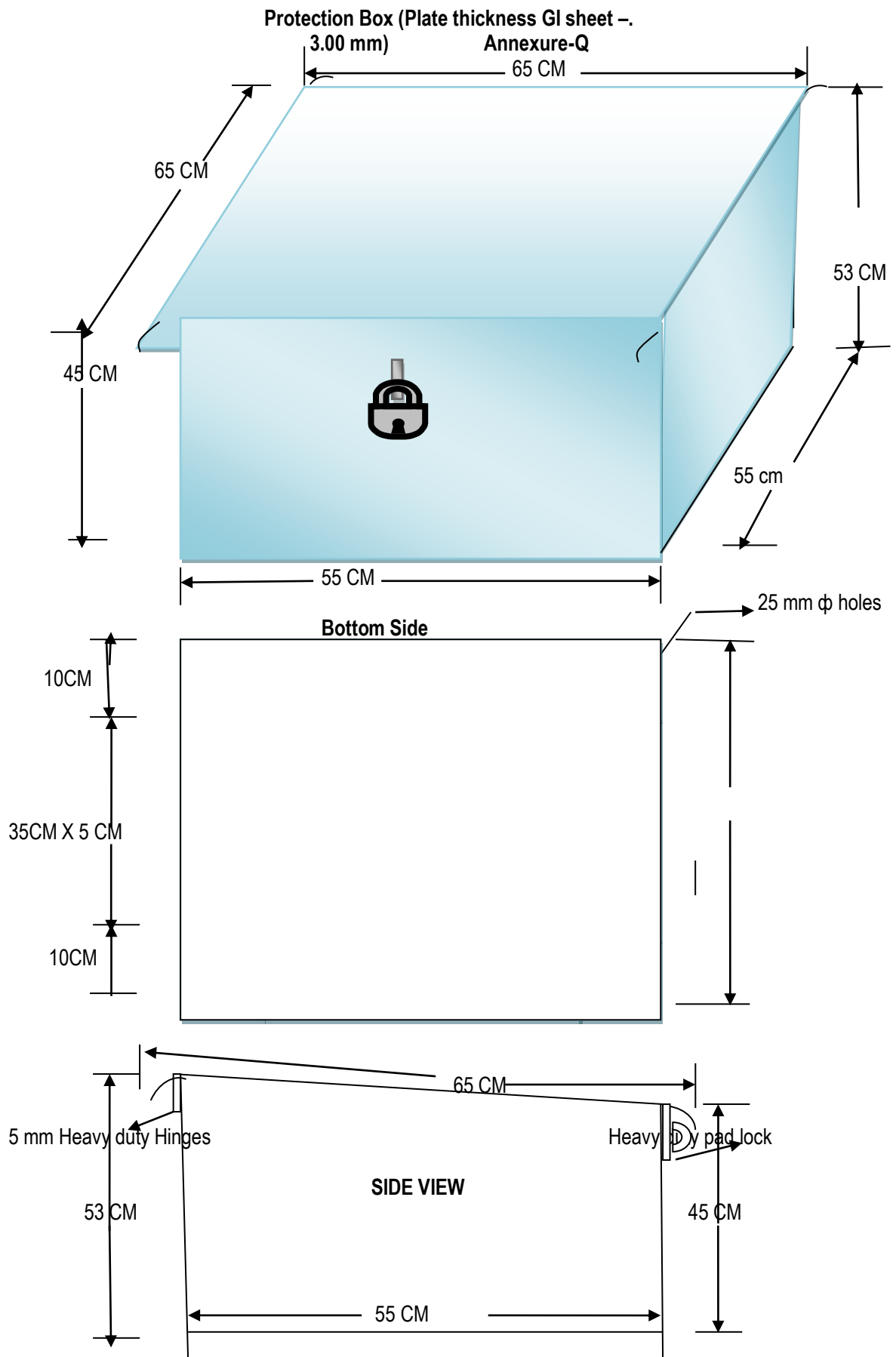

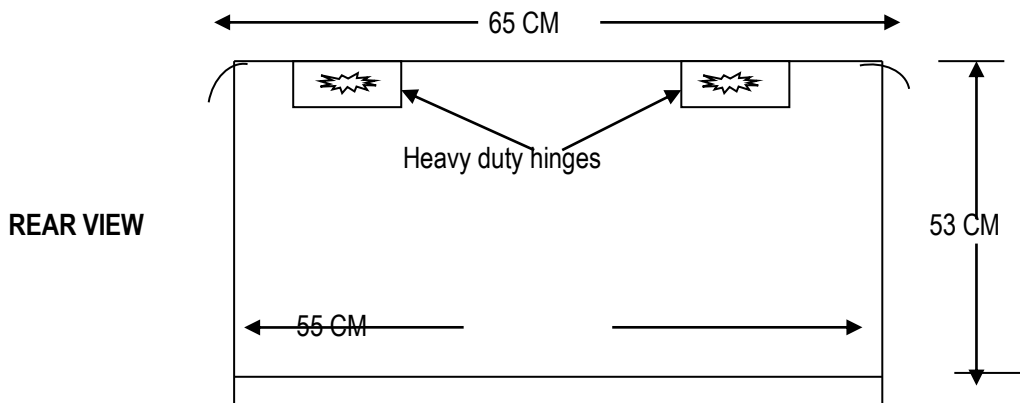
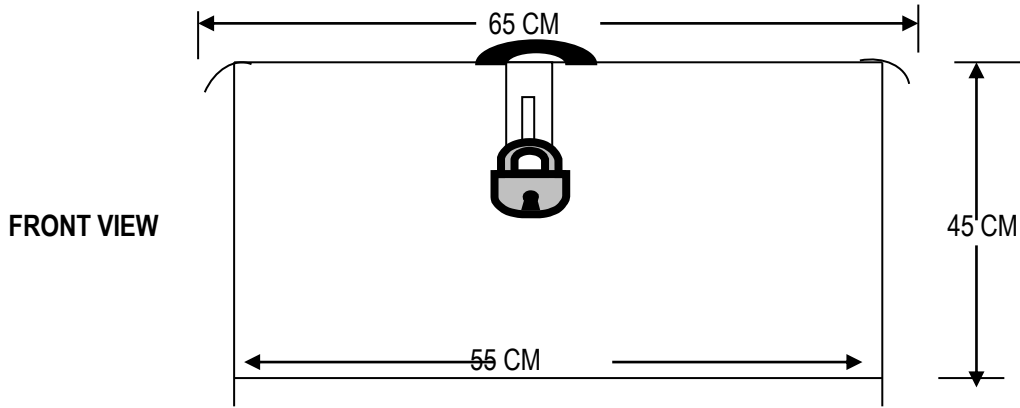

COVER PLATE OF SIZE:
65 CM X 65 CM (with HANDLE and LOCK).
 The cover plate should have minimum 5 CM extra projection on all sides of box for safeguarding the box and lock against rainfall.
 The edges of sheet should not be sharp but should be rounded off.
 The thickness of the plate should be made of 3.00 mm GI sheet.
 Aluminium paint on all over welded joints
 Perforation shall be provided in the Protection Box on two sides

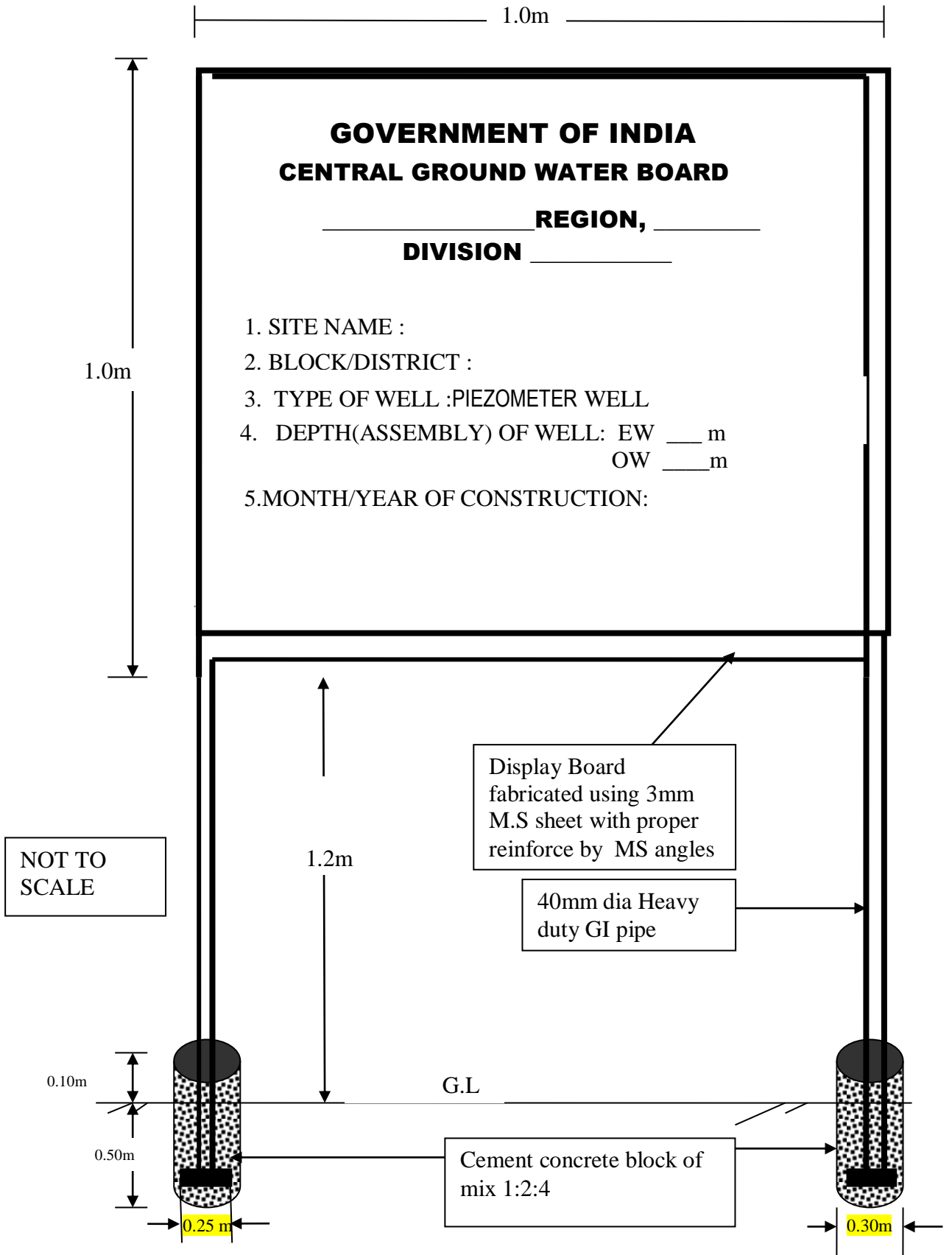

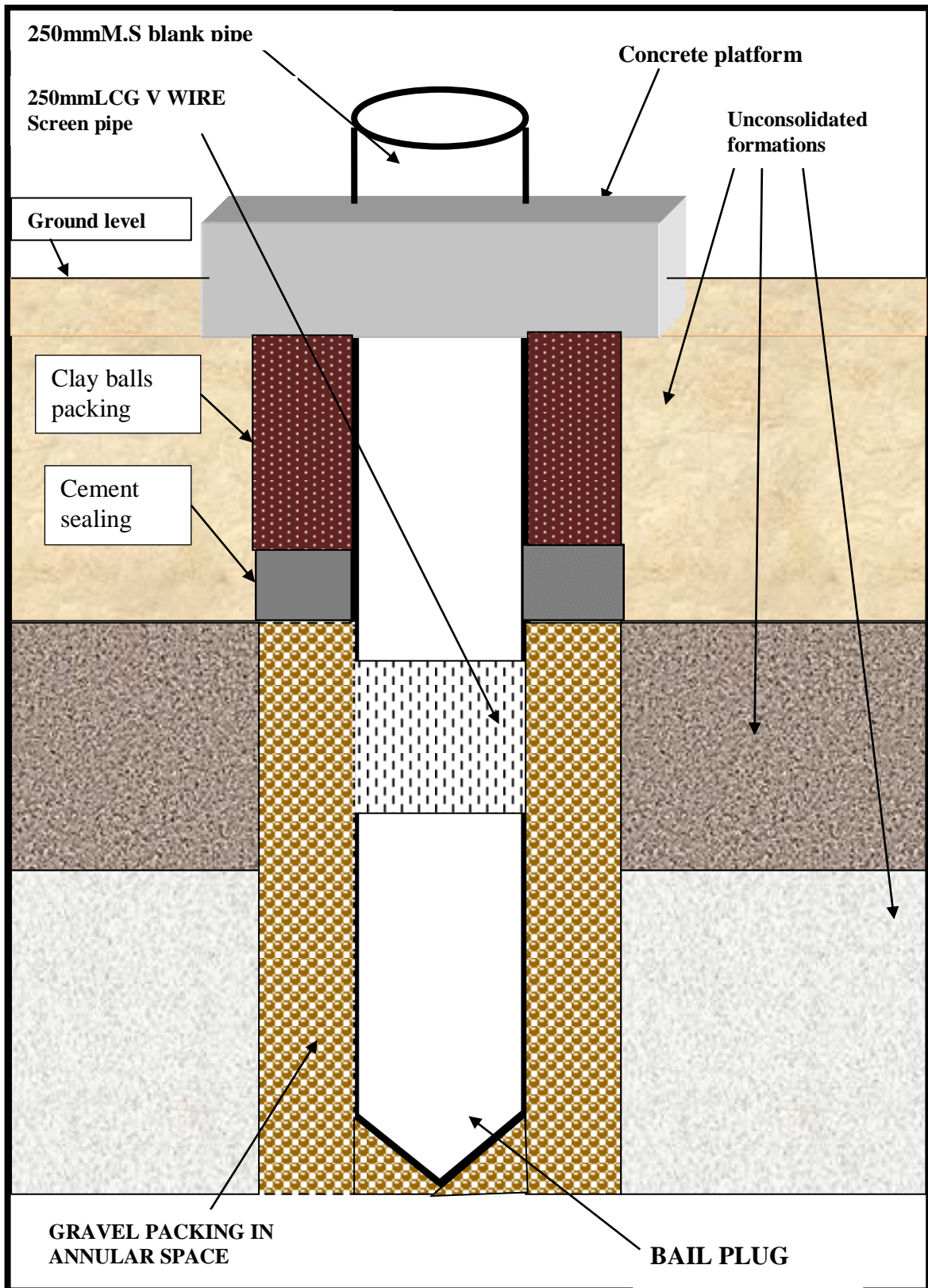

SAMPLE DESIGN OF PIEZOMETER WELL SOFT ROCK FORMATIONS.THE ACTUAL DESIGN WILL BE DECIDED BY THE SITE HYDROGEOLOGIST WITH THE APPROVAL OF REGIONAL DIRECTOR.

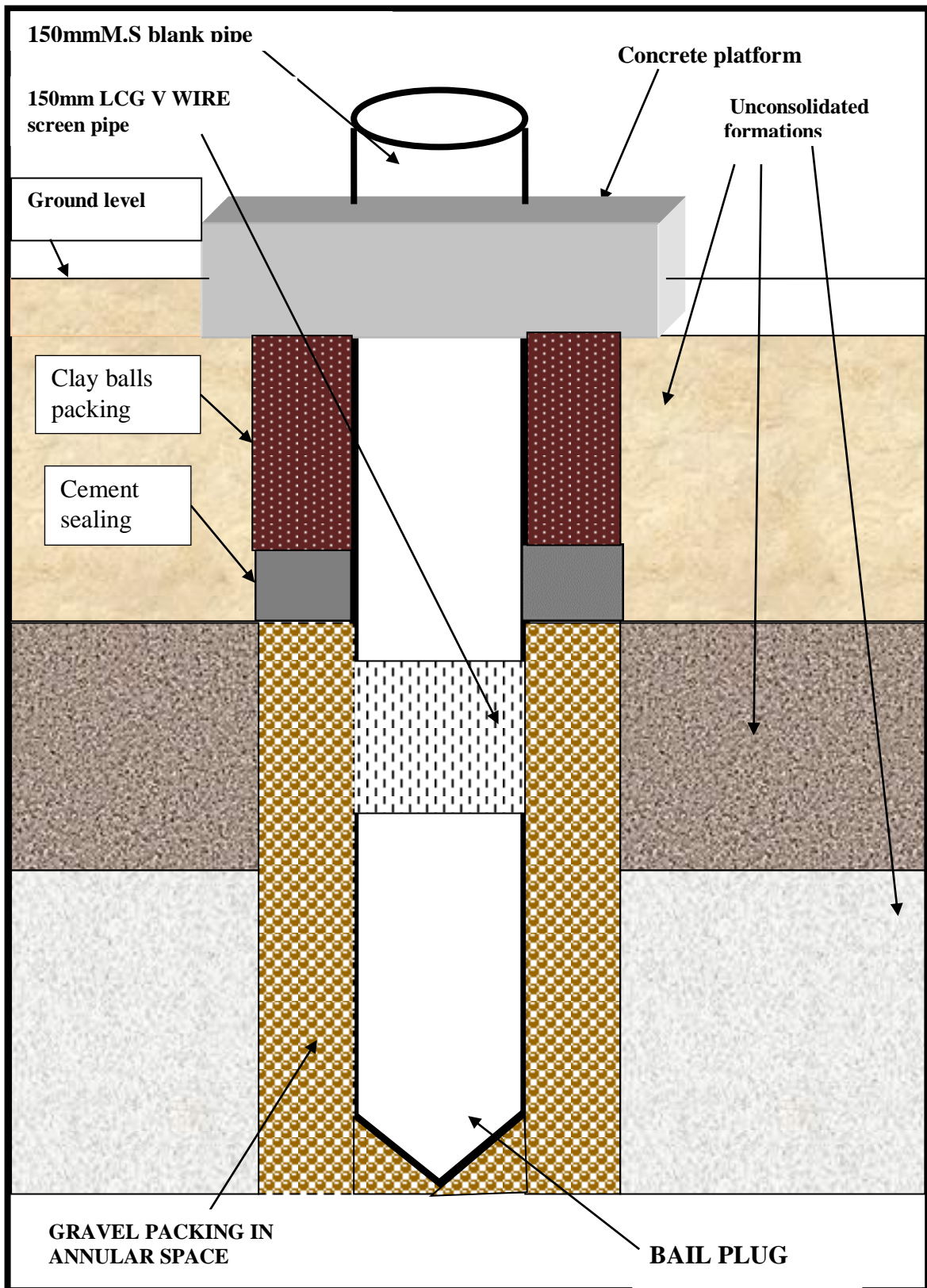

SAMPLE DESIGN OF PIEZOMETER WELL IN SOFT ROCK FORMATIONS.THE ACTUAL DESIGN WILL BE DECIDED BY THE SITE HYDROGEOLOGIST WITH THE APPROVAL OF REGIONAL DIRECTOR.

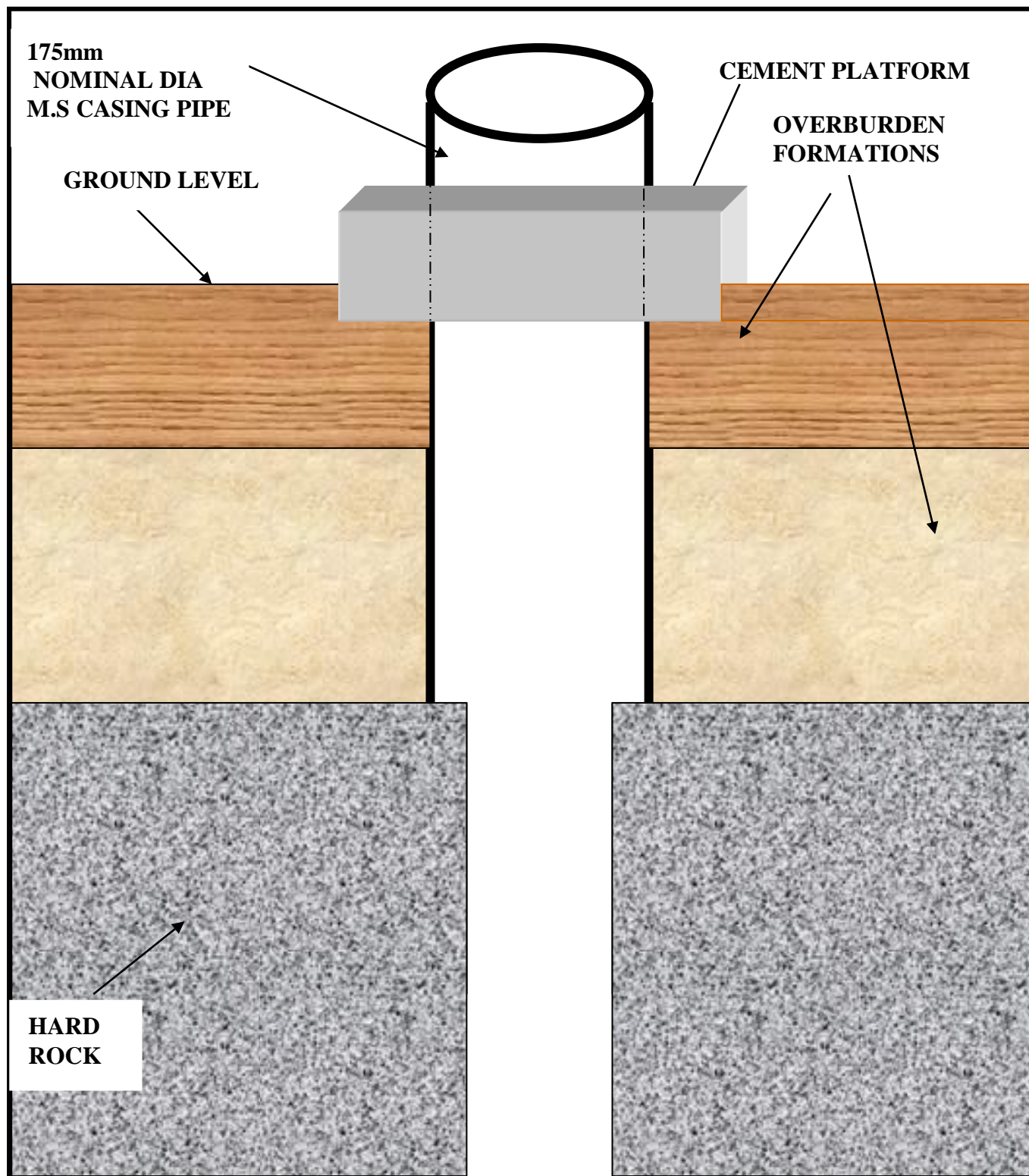

FIG: SAMPLE DESIGN OF 200m Depth PZ/ EW& OW IN HARD ROCK FORMATION (sample figure)

SECTION- X
BIDDING DATA

SECTION- X

BIDDING DATA

Summary of Works:

(Construction of 810 Piezometer Wells and supply , Installation, Commissioning of DWLRs and telemetry, establishment of Data Acquisition System and its maintenance for real time Ground Water Level Monitoring and supply of Ground Water Level, Ground Water Temperature Data from site and receipt of Data at National Data Centre, CHQ, Faridabad in a desired format from above constructed Piezometer wells through telemetry systems 05 years warranty and 02 years AMC in the state of Uttar Pradesh, Bihar, Jharkhand, West Bengal And Odisha.

Name and address of the employer- **Chairman, Central Ground Water Board, Bhujal Bhawan, NH-IV Faridabad-121001 (Haryana)**

Period of bid validity- **120 Days**

Amount of earnest money

Tender ID	Name of Package	Region	Estimated Cost in INR excluding GST	EMD in INR
	Package 6	Uttar Pradesh, Bihar, Jharkhand, West Bengal And Odisha	66,84,70,500/-	1,33,69,410/-

Venue, time and date of bid opening- Bhujal Bhawan, NH-IV, **Central Ground Water Board, Faridabad-121001**

Standard form and amount of performance guarantee acceptable to the employer in **Section-XIII and 3% of the Bid Price**

Security Deposit:**As per tender document**

Bill of Quantities (as per standard form)-

The summary of package has been provided in Section-VI (Bill of Quantities and Summary of package). The detailed Bill of Quantities for PACKAGE-6 of Uttar Pradesh, Bihar, Jharkhand, West Bengal And Odisha may be seen in the BOQ section uploaded in the e-tendering system which is an integral part of this tender document.

Clause 3.1

- i) Time allowed for submission of Performance Guarantee from the date of issue of letter of acceptance. - **21 days**
- ii) Maximum allowable extension beyond the period provided in i) above- **7 days**

Clause 4.1

Specifications to be followed
for execution of work – **As defined in following sections:**
Section-V Scope of work and Technical Specifications
Section-VI Bill of Quantities and Summary of Packages

Clause 4.2 Maximum percentage for quantity of items of work to be executed beyond which rates are to be determined in Accordance with Clauses –4.2.

Clause 4.3 Competent authority for deciding reduced rates

Chairman, CGWB

Clause 4.4 Defects Liability Period

365 days from the date of completion of work

Clause 4.6

Requirement of Technical Representative(s) and Recovery Rate

S.No.	Minimum Qualification of Technical Representative	Discipline	Designation (Principal Technical/Technical representative)	Minimum experience	Number	Rate at which recovery shall be made from the contractor in the event of not fulfilling provision of Clause 4.6	
						Figures	Words
1	Graduate Degree in Engineering / Master's Degree in Geosciences	Engineering / Geosciences	Groundwater Professional	Minimum 3 years of experience in construction of water wells, borehole logging, conducting pumping tests, interpreting/analysing related data and preparation of reports.	Minimum one	Rs.2000/- per day	Rupees Two Thousand per day

Retired Government Officer served at minimum level of Assistant Engineer or equivalent with Diploma qualification will be treated at par with Graduate Engineers.

Clause 8.1

Number of days from the date of issue of letter of acceptance for reckoning date of start **15 days**

Time allowed for execution of work **660 days**

Authority to give fair and reasonable extension of time for completion of work with and without Liquidated Damages

S.N	Authority	Extension of time
1	DoWR, RD&GR	Full Powers

Clause 8.2

Competent authority for fixing compensation **Chairman CGWB**

Clause 9.1

Dispute resolution board shall consists of following members

- i) **The concerned Member, CGWB under whose jurisdiction the work is being executed**
- ii) **The FAO, CGWB**
- iii) **The Regional Director, CGWB of the concerned Region/s.**
- iv) **The Superintending Engineer, CGWB under concerned Member.**

Clause 9.2

Appointing authority for Arbitrator **Chairman, CGWB**

SECTION- XI
FORMATS
FOR
QUALIFICATION INFORMATION

SECTION- XI

FORMATS FOR QUALIFICATION INFORMATION

- 1 The information to be filled in by the Bidder in the following pages will be used to ascertain responsiveness of the bidder as per eligibility criteria provided for in Clause 2 of the Instructions to Bidders. This information will not be incorporated in the Contract.

1.1 For Individual Bidders

(Refer Clause 2.2 of ITB)

Constitution or legal status of Bidder:

[Attach copy]

Place of registration:

[Attach copy of Registration Certificate]

Principal place of business:

Power of attorney of signatory of Bid:

[Attach copy]

2 Annual turnover for last three financial years

(Refer Clause 2.3 of ITB)

Financial Year	Turnover (INR)

3 (a) Details of similar works successfully completed during last seven years

(Refer Clause 2.4 of ITB)

Financial Year	S. No	Employer	Work order/ Agreement reference	Description of Work	Date of Completion	Value of Contract	Page No of documentary proof enclosed in the bid

***Documentary proof from Employer should be enclosed**

(b)Details for proof of payment in respect of Works mentioned in Table 3(a) .

(Refer Clause 2.4 of ITB)

SI No.	Name of the Employer	Work Order/ Agreement Reference	Payment Recieved	Page no of Documentary proof for payment received enclosed in the Bid

4. **Details of tubewells/ borewells constructed by the bidder during last seven years**
(Refer Clause 2.6 of ITB)

S. No.	Type of formation /strata viz. Hardrock, Softrock, Coal, Gas etc	Depth of Well	No. of Wells	Page Nos of Documentary proof given in this regard

Note: The final decision in respect of Type of formation/strata viz. Hardrock, Softrock/Alluvial etc. shall be of CGWB and shall be binding to the bidders.

5. In case of a consortium, attach certified copy of the agreement between various partners identifying the parts and components of the system for which the concerned partner is responsible for execution. Furnish the information as required under Clause 1 to 4 for each partner individually (Refer Clause 2.2 of ITB).
6. Please provide a complete plan of operation for executing the work of packages bid for in the timeframe prescribed for completion of work, including information about availability of drilling rigs and other drilling/ geophysical equipment (owned/ hired/ leased/ to be procured).

7. **Checklist for EMD**

S.N.	Name of item	EMD in INR	Form of EMD (Account Payee Demand Draft/Fixed Deposit Receipt/Banker's Cheque/Bank Guarantee)	Amount of EMD (Amount shouldn't be less than the amount mentioned in Col.3)	Date of issue of EMD	EMD Expiry Date (EMD shall be valid for a period of (120 + 60) = 180 days from the last date of submission of bid*)
1	2	3	4	5	6	7

*In case last date of submission of bid has been extended, 180 days shall be counted from extended date.

----XXXXXXXXXX----

SECTION- XII

BANK GUARANTEE FORM FOR EMD

SECTION- XII

BANK GUARANTEE FORM FOR EMD

To

The President of India
Acting through
Drawing & Disbursing Officer, Central Ground Water Board, Bhujal Bhawan, NH-IV,
Faridabad-121001.

WHEREAS {Name and Address of Tenderer} (hereinafter called "the tenderer") has submitted its quotation (hereinafter called the "tender") dated {} for supply of {Short Description of Goods and Services} against the Employer's tender inquiry No. {} dated {}

Know all persons by these presents that we {Name of Bank}(hereinafter called the "Bank") having our registered office at {Address of Bank}are bound unto {Name of Employer}(hereinafter called the "Employer") in the sum of {Amount} for which payment will and truly to be made to the said Employer, the Bank binds itself, its successors and assigns by these presents.

Sealed with the Common Seal of the said Bank this{Specify Day} day of {Specify Month and Year}.

The conditions of this obligation are:

- (a) If the Tenderer withdraws or amends, impairs or derogates from the tender in any respect within the period of validity of this tender.
- (b) If the Tenderer having been notified of the acceptance of his tender by the Employer during the period of its validity:
 - (i) fails or refuses to furnish the performance security for the due performance of the contract.
 - (ii) fails or refuses to accept/execute the contract.

We undertake to pay the Employer up to the above amount upon receipt of its first written demand, without the Employer having to substantiate its demand, provided that in its demand the Employer will note that the amount claimed by it is due to it owing to the occurrence of one or both the two conditions, specifying the occurred condition(s).

This guarantee will remain in force for a period of 60 (sixty) days after the period of tender validity and any demand in respect thereof should reach the Bank not later than the above date.

{Signature of the Authorised Officer of the Bank}
{Name and Designation of the Officer}
{Seal, Name & Address of the Branch of the Bank}

SECTION- XIII
BANK GUARANTEE FORM
FOR
PERFORMANCE SECURITY AND MOBILISATION ADVANCE

SECTION- XIII

BANK GUARANTEE FORM FOR PERFORMANCE SECURITY

To
The President of India
Acting through
Drawing & Disbursing Officer, Central Ground Water Board, Bhujal Bhawan,
Faridabad

WHEREAS {Name and Address of Supplier} (hereinafter called "the supplier") has undertaken, in pursuance of Contract No {} dated {} to supply {Short Description of Goods and Services} (herein after called "the contract").

AND WHEREAS it has been stipulated by you in the said contract that the supplier shall furnish you with a bank guarantee by a scheduled commercial bank recognised by you for the sum specified therein as security for compliance with its obligations in accordance with the contract;

AND WHEREAS we have agreed to give the supplier such a bank guarantee;

NOW THEREFORE we hereby affirm that we are guarantors and responsible to you, on behalf of the supplier, up to a total of {amount of the guarantee in words and figures}, and we undertake to pay you, upon your first written demand declaring the supplier to be in default under the contract and without cavil or argument, any sum or sums within the limits of {amount of the guarantee }, as aforesaid, without your needing to prove or to show grounds or reasons for your demand or the sum specified therein.

We hereby waive the necessity of your demanding the said debt from the supplier before presenting us with the demand.

We further agree that no change or addition to or other modification of the terms of the contract to be performed thereunder or of any of the contract documents which may be made between you and the supplier shall in any way release us from any liability under this guarantee and we hereby waive notice of any such change, addition or modification.

This guarantee shall be valid up to and including the {Specify Day} day of {Specify Month and Year}.

{Signature of the Authorised Officer of the Bank}
{Name and Designation of the Officer}
{Seal, Name & Address of the Branch of the Bank}

PROFORMA FOR BANK GUARANTEE FOR ADVANCE FOR MOBILISATION

To
The President of India
Acting through
Drawing & Disbursing Officer, Central Ground Water Board, Bhujal Bhawan, Faridabad

In consideration of Central Ground Water Board (hereinafter referred to as "the Employer") which expression shall, unless repugnant to the context or meaning thereof include its successors, administrators and assigns) having awarded to _____ (Contractor's name) with its Registered /Head Office at _____ (hereinafter referred to as "the Contractor " which expression shall unless repugnant to the context or meaning thereof, include its successors, administrators, executors and assigns) a contract, by issue of Employer's Notification of Award No. _____ dt. _____ and the same having been unequivocally accepted by the Contractor, resulting into a contract valued at Rs. _____ (Rupees) _____ only) for _____ (hereinafter called " the contract") and the Employer having agreed to make an advance payment to the Contractor for performance of the above Contract amounting to Rs. _____ (Rupees _____ only) as an advance against bank guarantee to be furnished by the Contractor.

We, _____ (name & address of bank) having its Head Office at _____ (hereinafter referred to as "the Bank" which expression shall, unless repugnant to the context or meaning thereof, include its successors, administrators, executors and assigns) do hereby guarantee and undertake to pay the Employer immediately on demand any or, all monies payable by the Contractor to the extent of Rs. _____ (Rupees _____ only) as aforesaid at any time upto _____ without any demur, reservation, contest , recourse or protest and/or without any reference to the Contractor. Any such demand made by the Employer on the bank shall be conclusive and binding notwithstanding any difference between the Employer and the Contractor or any dispute pending before any Court, Tribunal, Arbitrator or any other authority. We agree that the Guarantee herein contained shall be irrevocable and shall continue to be enforceable till the Employer discharges this guarantee. We further agree that no change in the constitution of the Bank or of the Employer shall affect this guarantee.

The Employer shall have the fullest liberty without affecting in any way the liability of the Bank under this guarantee, from time to time, to vary the advance or to extend the time for performance of the Contract by the Contractor. The Employer shall have the fullest liberty without affecting this guarantee, to postpone from time to time the exercise of any powers vested in them or of any right which they might have against the Contractor and to exercise the same at any time in any manner, and either to enforce or to for bear to enforce any covenants, contained or implied, in the Contract between the Employer and the Contractor or any other course or remedy or security available to the Employer. The bank shall not be released of its obligations under these presents by any exercise by the Employer of its liberty with reference to the matters aforesaid or any of them or by reason of any other act or forbearance or other acts of omission or commission on the part of the Employer or any other indulgence shown by the Employer or by any other matter or thing whatsoever which under law would but for this provision, have the effect of relieving the Bank.

The bank also agrees that the Employer at its option shall be entitled to enforce this Guarantee against the Bank as a principal debtor, in the first instance without proceeding against the Contractor and not withstanding any security or other guarantee that the Employer may have in relation to the Contractor's liabilities.

We the said bank do hereby declare and undertake that your claim under the guarantee shall not be affected by any deficiency or other defect in the powers of the bank or its officials and the guarantee

shall be deemed to have been issued as if the bank and its officials have all the powers and authorization to give this guarantee on behalf of the bank.

We the said bank does hereby certify the genuineness and appropriateness of the Stamp paper and stamp value used for issuing the guarantee. We the said bank do hereby declare and undertake that your claim under the guarantee shall not be affected by any deficiency or other defect in the stamp paper or its stamp value.

We the said bank do hereby declare that our payments hereunder shall be made to you , free and clear of and without and deduction, reduction on account of any reasons including any and all present and future taxes, levies, charges of withholding whatsoever imposed or collected with respect thereto.

Notwithstanding anything contained hereinabove our liability under this guarantee is limited to Rs. _____ (Rupees _____ only) and it shall remain in force upto and including _____ and shall be extended from time to time for such period (not exceeding one year), as may be desired by M/S _____ on whose behalf this bank guarantee has been given.

Notwithstanding anything contained herein

i) our liability under this guarantee shall not exceed Rs. _____ (Rupees _____ only);

ii) This bank guarantee shall be valid upto and till _____ only, being the date of expiry of the guarantee and

iii) We are liable to pay up to the guaranteed amount only and only if we receive from you a written claim or demand within the claim period not later than 12 months from the said expiry date relating to default that happened during the guarantee period and all your rights under this bank guarantee shall be extinguished and our liability under the bank guarantee shall stand discharged unless such written claim or demand is received by us from you on or before being the date of expiry of the guarantee

Dated this _____ day of _____ at Faridabad.

WITNESS

(Signature)

(Name)

(Official address)

(Signature)

(Name)

(Signature)

(Name)

(Designation with bank stamp)

Attorney as Power of Attorney

No. _____ dt. _____

SECTION- XIV
TENDER ACCEPTANCE LETTER
AND
INTEGRITY PACT

SECTION- XIV

TENDER ACCEPTANCE LETTER

From
{Name and Address of Tenderer}

Date

To
The Superintending Engineer
Central Ground Water Board
Bhujal Bhawan, NH-IV,
Faridabad, Pin-121001

Subject: Construction of PiezometerWells and supply , Installation, Commisioning of DWLRs and telemetry, establishment of Data Acquisition System and its maintenance for real time Ground Water Level Monitoring and supply of Ground Water Level, Ground Water Tremperature Data from site and receipt of Data at National Data Centre, CHQ, Faridabad in a desired format from above constructed Piezometer wells through telemetry sytems 05 years warranty and 02 years AMC in the state of Uttar Pradesh, Bihar, Jharkhand, West Bengal And Odisha

Reference: Your Tender Enquiry Document No.{Number} dated {Date}

Dear sir,

1. I/ We have downloaded/ obtained the tender document(s) for the above mentioned 'Goods/Work' from <http://cgwb.gov.in> or the Central Public Procurement portal of Government of India <http://eprocure.gov.in/eprocure/app> as per your advertisement, given in the above mentioned websites.
2. I/ We hereby certify that I/ we have read the entire terms and conditions of the tender documents from Page No. _____ to _____ {including all documents like annexure(s), schedule(s), etcetera}, which form part of the contract agreement and I/ we shall abide by the terms/ conditions/ clauses contained therein.
3. The corrigendum(s) issued from time to time by your department/ organization too has also been taken into consideration, while submitting this acceptance letter.
4. I/ We hereby unconditionally accept the tender conditions of above mentioned tender document(s)/ corrigendum(s) in its totality / entirety.
5. I/ We hereby declare that our firm have never been under a declaration of non-ineligibility for corrupt and fraudulent practices issued by any Court or Government Department or Public Sector Undertaking and not blacklisted for non-compliance of any contract by any Government Department or Public Sector Undertaking.
6. I / We certify that all information furnished by us is true and correct and in the event that the information is found to be untrue/ incorrect or found violated, then your department/ organization shall, without giving any notice or reason thereof, summarily reject the bid or terminate the contract, without prejudice to any other rights or remedy including the forfeiture of the earnest money deposited by us.

Yours faithfully,

(Signature of the Tenderer, with Official Seal)

INTEGRITY PACT

(To be signed on Plain Paper)
(To be submitted as part of Technical Bid)

Integrity Pact for Tender Document No. Tender No. _____, Tender Title: Construction of Piezometer Wells and supply , Installation, Commissioning of DWLRs and telemetry, establishment of Data Acquisition System and its maintenance for real time Ground Water Level Monitoring and supply of Ground Water Level, Ground Water Temperature Data from site and receipt of Data at National Data Centre, CHQ, Faridabad in a desired format from above constructed Piezometer wells through telemetry systems 05 years warranty and 02 years AMC in the state of UTTARPRADESH, BIHAR, JHARKHAND, WEST BENGAL and ODISHA

This Agreement (hereinafter called the Integrity Pact) is made on _____ day of the month of _____ 202__ at _____, India

BETWEEN

Procuring Organisation, ----- through Head of Procuring Organisation, for and on behalf of President of India (hereinafter called the "The Principal", which expression shall mean and include, unless the context otherwise requires, his successors in office and assigns) of the First Part

AND

M/ s. _____ (hereinafter called the "The Bidder/ Contractor" which expression shall mean and include, unless the context otherwise requires, his successors and permitted assigns) of the Second Part.

PREAMBLE

'The Principal' intends to award, under laid down organizational procedures, contract/ s for _____, 'The Principal' values full compliance with all relevant laws of the land, rules, regulations, economic use of resources and of fairness/ transparency in its relations with its Bidder(s) and/ or Contractor(s).

In order to achieve these goals, the Principal shall appoint Independent External Monitors (IEMs) who shall monitor the tender process and the execution of the contract for compliance with the principles mentioned above.

Section 1 - Commitments of the 'The Principal' 1.

1. 'The principal' commits itself to take all measures necessary to prevent corruption and to observe the following principles:
 - a. No employee of the principal, personally or through family members, shall in connection with the tender for, or the execution of a contract, demand, take a promise for or accept, for self or third person, any material or immaterial benefit which the person is not legally entitled to.
 - b. The principal shall, during the tender process treat all Bidder(s) with equity and reason. The principal shall in particular, before and during the tender process, provide to all Bidder(s) the same information and shall not provide to any Bidder(s) confidential/ additional information through which the Bidder(s) could obtain an advantage in relation to the tender process or the contract execution.
 - c. The Principal shall exclude from the process all known prejudiced persons.
2. If the Principal obtains information on the conduct of any of its employees which is a criminal offence under the IPC/ PC Act, or if there be a substantive suspicion in this regard, the Principal

shall inform the Chief Vigilance Officer and in addition can initiate disciplinary actions.

Section 2 - Commitments of the 'Bidder/ Contractor'

1. The 'Bidder/ Contractor' commit themselves to take all measures necessary to prevent corruption. The 'Bidder/ Contractor' commit themselves to observe the following principles during participation in the tender process and during the contract execution.

a. The 'Bidder/ Contractor' shall not, directly or through any other person or firm, offer, promise, or give to any of the Principal's employees involved in the tender process or the execution of the contract or to any third person any material or other benefit which he/ she is not legally entitled to, in order to obtain in exchange any advantage of any kind whatsoever during the tender process or during the execution of the contract.

b. The 'Bidder/ Contractor' shall not enter with other Bidders into any undisclosed agreement or understanding, whether formal or informal. This applies in particular to prices, specifications, certifications, subsidiary contracts, submission or non-submission of bids or any other actions to restrict competitiveness or to introduce cartelization in the bidding process.

c. The 'Bidder/ Contractor' shall not commit any offence under the relevant IPC/ PC Act; further the 'Bidder/ Contractor' shall not use improperly, for purposes of competition or personal gain, or pass on to others, any information or document provided by the Principal as part of the business relationship, regarding plans, technical proposals, and business details, including information contained or transmitted electronically.

d. The 'Bidder/ Contractor' of foreign origin shall disclose the name and address of the Agents/ representatives in India, if any. Similarly, the Bidder/ Contractors of Indian Nationality shall furnish the name and address of the foreign principals, if any. Further details as mentioned in the "Guidelines on Indian Agents of Foreign Suppliers" shall be disclosed by the Bidder/ Contractor. Further, as mentioned in the Guidelines all the payments made to the Indian agent/ representative have to be in Indian Rupees only. Copy of the "Guidelines on Indian Agents of Foreign Suppliers" is placed at Annexe to this agreement.

e. The 'Bidder/ Contractor' shall, when presenting their bid, disclose any and all payments made, is committed to, or intends to make to agents, brokers, or any other intermediaries in connection with the award of the contract.

f. Bidder/ Contractor who have signed the Integrity Pact shall not approach the Courts while representing the matter to IEMs and shall wait for their decision in the matter.

2. The 'Bidder/ Contractor' shall not instigate third persons to commit offences outlined above or be an accessory to such offences.

Section 3 - Disqualification from tender process and exclusion from future contracts

If the 'Bidder/ Contractor', before award or during execution has committed a transgression through a violation of Section 2, above or in any other form such as to put their reliability or credibility in question, the Principal is entitled to disqualify the 'Bidder/ Contractor' from the tender process or take action as per the procedure mentioned in the "Guidelines on Banning of business dealings".

Section 4 - Compensation for Damages

1. If the Principal has disqualified the 'Bidder/ Contractor' from the tender process prior to the award according to Section 3, the Principal is entitled to demand and recover from 'Bidder/Contractor' the damages equivalent to Earnest Money Deposit/ Bid Security.

2. If the Principal has terminated the contract according to Section 3, or if the Principal is entitled to terminate the contract according to Section 3, the Principal shall be entitled to demand and recover from the Contractor liquidated damages of the Contract value or the amount equivalent to Performance Bank Guarantee.

Section 5 - Previous transgression

1. The Bidder declares that no previous transgressions occurred in the last three years with any other Company in any country conforming to the anti-corruption approach or with any Public Sector Enterprise in India that could justify his exclusion from the tender process.

2. If the Bidder makes incorrect statement on this subject, he can be disqualified from the tender process or action can be taken as per the procedure mentioned in "Guidelines on Banning of business dealings".

Section 6 - Equal treatment of all Bidders/ Contractors/ Subcontractors

1 In case of Sub-contracting, the Principal Contractor shall take the responsibility of the adoption of Integrity Pact by the Sub-contractor.

2 The Principal shall enter into agreements with identical conditions as this one with all Bidders and Contractors.

3 The Principal shall disqualify from the tender process all bidders who do not sign this Pact or violate its provisions.

Section 7 - Criminal charges against violating Bidder(s)/ Contractor(s)/ Subcontractor(s)

If the Principal obtains knowledge of conduct of a Bidder, Contractor or Subcontractor, or of an employee or a representative or an associate of a Bidder, Contractor or Subcontractor which constitutes corruption, or if the principal has substantive suspicion in this regard, the principal shall inform the same to the Chief Vigilance Officer.

Section 8 - Independent External Monitor

1 The Principal appoints competent and credible Independent External Monitor for this Pact after approval by Central Vigilance Commission. The task of the Monitor is to review independently and objectively, whether and to what extent the parties comply with the obligations under this agreement.

2 The Monitor is not subject to instructions by the representatives of the parties and performs his/her functions neutrally and independently. The Monitor would have access to all Contract documents, whenever required. It shall be obligatory for him/ her to treat the information and documents of the Bidders/ Contractors as confidential. He/ she reports to Head of Procuring Organization of Procuring Organization.

3 The Bidder(s)/ Contractor(s) accepts that the Monitor has the right to access without restriction to all Project documentation of the Principal including that provided by the Contractor. The Contractor shall also grant the Monitor, upon his/ her request and demonstration of a valid interest, unrestricted and unconditional access to their project documentation. The same is applicable to Sub-contractors.

4 The Monitor is under contractual obligation to treat the information and documents of the Bidder/ Contractor(s)/ Sub-contractor(s) with confidentiality. The Monitor has also signed declarations on 'Non-Disclosure of Confidential Information' and of 'Absence of Conflict of Interest'. In case of any conflict of interest arising at a later date, the IEM shall inform Head of Procuring Organization of Procuring Organization and recues himself/ herself from that case.

5. The Principal shall provide to the Monitor sufficient information about all meetings among the

parties related to the Project provided such meetings could have an impact on the contractual relations between the Principal and the Contractor. The parties offer to the Monitor the option to participate in such meetings.

6. As soon as the Monitor notices, or believes to notice, a violation of this agreement, he/ she shall so inform the Management of the Principal and request the Management to discontinue or take corrective action, or to take other relevant action. The monitor can in this regard submit non-binding recommendations. Beyond this, the Monitor has no right to demand from the parties that they act in a specific manner, refrain from action, or tolerate action.

7. The Monitor shall submit a written report to Head of Procuring Organisation of Procuring Organisation within 8 to 10 weeks from the date of reference or intimation to him by the principal and, should the occasion arise, submit proposals for correcting problematic situations.

8. If the Monitor has reported to Head of Procuring Organisation of Procuring Organisation, a substantiated suspicion of an offence under relevant IPC/ PC Act, and Head of Procuring Organisation of Procuring Organisation has not, within the reasonable time taken visible action to proceed against such offence or reported it to the Chief Vigilance Officer, the Monitor may also transmit this information directly to the Central Vigilance Commissioner.

9. The word 'Monitor' would include both singular and plural.

Section 9 - Pact Duration

This Pact begins when both parties have legally signed it. It expires for the Contractor 12 months after the last payment under the contract, and for all other Bidders 6 months after the contract has been awarded. Any violation of the same would entail disqualification of the bidders and exclusion from future business dealings.

If any claim is made/ lodged during this time, the same shall be binding and continue to be valid despite the lapse of this pact as specified above, unless it is discharged/ determined by Head of Procuring Organisation of Procuring Organisation.

Section 10 - Other provisions

1 This agreement is subject to Indian Law. Place of performance and jurisdiction is the Registered Office of the Principal, i.e., Faridabad.

2 Changes and supplements as well as termination notices need to be made in writing. Side agreements have not been made.

3 If the Contractor is a partnership or a consortium, this agreement must be signed by all partners or consortium members.

4 Should one or several provisions of this agreement turn out to be invalid, the remainder of this agreement remains valid. In this case, the parties shall strive to come to an agreement to their original intentions.

5 Issues like Warranty/ Guarantee etc. shall be outside the purview of IEMs.

6 In the event of any contradiction between the Integrity Pact and its Annexure, the Clause in the Integrity Pact shall prevail.

For and on behalf of the principal

(Name of the Officer and Designation)

(Office Seal)

For and on behalf of 'Bidder/ Contractor'

(Name of the Officer and Designation)

(Office Seal)

For and on Behalf of the Principal

Place

Date

Witness 1:

(Name & Address)

Witness 2:

(Name & Address)

Date:

Annexe to Integrity Pact

Guidelines for Indian Agents of Foreign Bidders

1.0 There shall be compulsory registration of agents for all Global (Open) Tender and Limited Tender. An agent who is not registered with 'The Principal' shall apply for registration in the registration form with appropriate unit.

1.1 Registered agents shall file an authenticated Photostat copy duly attested by a Notary Public/ Original certificate of the Principal confirming the agency agreement. It should cover - the precise relationship, services to be rendered, mutual interests in business - generally and/ or specifically for the tender. Any commission/ remuneration/ salary/ retainer ship, which the agent or associate receives in India or abroad from the OEM, whether should be brought on record in the Agreement and be made explicit.

1.2 Wherever the Indian representatives have communicated on behalf of their principals and the foreign parties have stated that they are not paying any commission to the Indian agents, and the Indian representative is working on the basis of salary or as retainer, a written declaration to this effect should be submitted by the party (i.e., Principal) before finalizing the order.

2.0 Disclosure of particulars of agents/ representatives in India, if any.

2.1 Bidders of Foreign nationality shall furnish the following details in their offers:

2.1.1 The 'Bidder/ Contractor' of foreign origin shall disclose the name and address of the agents/ representatives in India if any and the extent of authorization and authority given to commit the Principals. In case the agent/ representative be a foreign Company, it shall be confirmed whether it is existing Company and details of the same shall be furnished.

2.1.2 The amount of commission/ remuneration included in the quoted price(s) for such agents/ representatives in India.

2.1.3 Confirmation of the Bidder that the commission/ remuneration, if any, payable to his agents/ representatives in India, may be paid by 'The Principal' in Indian Rupees only.

2.2 Bidders of Indian Nationality shall furnish the following details in their offers:

2.2.1 The 'Bidder/ Contractor' of Indian Nationality shall furnish the name and address of the foreign principals, if any, indicating their nationality as well as their status, i.e., whether manufacturer or agents of manufacturer holding the Letter of Authority of the Principal specifically authorizing the agent to make an offer in India in response to tender either directly or through the agents/ representatives.

2.2.2 The amount of commission/ remuneration included in the price (s) quoted by the Bidder for himself.

2.2.3 Confirmation of the foreign principals of the Bidder that the commission/ remuneration, if any, reserved for the Bidder in the quoted price(s), may be paid by 'The Principal' in India in equivalent Indian Rupees on satisfactory completion of the Project or supplies of Stores and Spares in case of operation items.

2.3 In either case, in the event of contract materializing, the terms of payment shall provide for payment of the commission/ remuneration, if any payable to the agents/ representatives in India in Indian Rupees on expiry of 90 days after the discharge of the obligations under the contract.

2.4 Failure to furnish correct and detailed information as called for in clauses above shall render the concerned tender liable to rejection or in the event of a contract materializing, the same liable to termination by 'The Principal'. Besides this there would be a penalty of banning business dealings with 'The Principal' or damage or payment of a named sum.

SECTION- XV

INSTRUCTIONS

FOR

ONLINE BID SUBMISSION

	SECTION- XV
	INSTRUCTIONS FOR ONLINE SUBMISSION OF BIDS
	<p>The bidders are required to submit soft copies of their bids electronically on the CPP Portal, using valid Digital Signature Certificates. The instructions given below are meant to assist the bidders in registering on the CPP Portal, prepare their bids in accordance with the requirements and submitting their bids online on the CPP Portal.</p> <p>More information useful for submitting online bids on the CPP Portal may be obtained at: https://eprocure.gov.in/eprocure/app.</p> <p>REGISTRATION</p> <ol style="list-style-type: none"> 1) Bidders are required to enroll on the e-Procurement module of the Central Public Procurement Portal (URL: https://eprocure.gov.in/eprocure/app) by clicking on the link “Online bidder Enrollment” on the CPP Portal which is free of charge. 2) As part of the enrolment process, the bidders will be required to choose a unique username and assign a password for their accounts. 3) Bidders are advised to register their valid email address and mobile numbers as part of the registration process. These would be used for any communication from the CPP Portal. 4) Upon enrolment, the bidders will be required to register their valid Digital Signature Certificate (Class II or Class III Certificates with signing key usage) issued by any Certifying Authority recognized by CCA India (e.g. Sify / TCS / nCode / eMudhra etc.), with their profile. 5) Only one valid DSC should be registered by a bidder. Please note that the bidders are responsible to ensure that they do not lend their DSC’s to others which may lead to misuse. 6) Bidder then logs in to the site through the secured log-in by entering their user ID / password and the password of the DSC / e-Token. <p>SEARCHING FOR TENDER DOCUMENTS</p> <ol style="list-style-type: none"> 1) There are various search options built in the CPP Portal, to facilitate bidders to search active tenders by several parameters. These parameters could include Tender ID, Organization Name, Location, Date, Value, etc. There is also an option of advanced search for tenders, wherein the bidders may combine a number of search parameters such as Organization Name, Form of Contract, Location, Date, Other keywords etc. to search for a tender published on the CPP Portal. 2) Once the bidders have selected the tenders they are interested in, they may download the required documents / tender schedules. These tenders can be moved to the respective ‘My Tenders’ folder. This would enable the CPP Portal to intimate the bidders through SMS / e-mail in case there is any corrigendum issued to the tender document. 3) The bidder should make a note of the unique Tender ID assigned to each tender, in case they want to obtain any clarification / help from the Helpdesk.

PREPARATION OF BIDS

- 1) Bidder should take into account any corrigendum published on the tender document before submitting their bids.
- 2) Please go through the tender advertisement and the tender document carefully to understand the documents required to be submitted as part of the bid. Please note the number of covers in which the bid documents have to be submitted, the number of documents - including the names and content of each of the document that need to be submitted. Any deviations from these may lead to rejection of the bid.
- 3) Bidder, in advance, should get ready the bid documents to be submitted as indicated in the tender document / schedule and generally, they can be in PDF / XLS / RAR / DWF/JPG formats. Bid documents may be scanned with 100 dpi with black and white option which helps in reducing size of the scanned document.
- 4) To avoid the time and effort required in uploading the same set of standard documents which are required to be submitted as a part of every bid, a provision of uploading such standard documents (e.g. PAN card copy, annual reports, auditor certificates etc.) has been provided to the bidders. Bidders can use "My Space" or "Other Important Documents" area available to them to upload such documents. These documents may be directly submitted from the "My Space" area while submitting a bid, and need not be uploaded again and again. This will lead to a reduction in the time required for bid submission process.

SUBMISSION OF BIDS

- 1) Bidder should log into the site well in advance for bid submission so that they can upload the bid in time i.e. on or before the bid submission time. Bidder will be responsible for any delay due to other issues.
- 2) The bidder has to digitally sign and upload the required bid documents one by one as indicated in the tender document.
- 3) Bidder has to select the payment option as "offline" to pay the tender fee / EMD as applicable and enter details of the instrument.
- 4) Bidder should prepare the EMD as per the instructions specified in the tender document. The original should be posted/couriered /given in person to the concerned official, latest by the last date of bid submission or as specified in the tender documents. The details of the DD/any other accepted instrument, physically sent, should tally with the details available in the scanned copy and the data entered during bid submission time. Otherwise the uploaded bid will be rejected.
- 5) Bidders are requested to note that they should necessarily submit their financial bids in the format provided and no other format is acceptable. If the price bid has been given as a standard BoQ format with the tender document, then the same is to be downloaded and to be filled by all the bidders. Bidders are required to download the BoQ file, open it and complete the white colored (unprotected) cells with their respective financial quotes and other details (such as name of the bidder). No other cells should be changed. Once the details have been completed, the bidder should save it and submit it online, without changing the filename. If the BoQ file is found to be modified by the bidder, the bid will be rejected.

	<p>6) The server time (which is displayed on the bidders' dashboard) will be considered as the standard time for referencing the deadlines for submission of the bids by the bidders, opening of bids etc. The bidders should follow this time during bid submission.</p> <p>7) All the documents being submitted by the bidders would be encrypted using PKI encryption techniques to ensure the secrecy of the data. The data entered cannot be viewed by unauthorized persons until the time of bid opening. The confidentiality of the bids is maintained using the secured Socket Layer 128 bit encryption technology. Data storage encryption of sensitive fields is done. Any bid document that is uploaded to the server is subjected to symmetric encryption using a system generated symmetric key. Further this key is subjected to asymmetric encryption using buyers/bid opener's public keys. Overall, the uploaded tender documents become readable only after the tender opening by the authorized bid openers.</p> <p>7) The uploaded tender documents become readable only after the tender opening by the authorized bid openers.</p> <p>8) Upon the successful and timely submission of bids (i.e. after Clicking "Freeze Bid Submission" in the portal), the portal will give a successful bid submission message and a bid summary will be displayed with the bid no. and the date and time of submission of the bid with all other relevant details.</p> <p>9) The bid summary has to be printed and kept as an acknowledgement of the submission of the bid. This acknowledgement may be used as an entry pass for any bid opening meetings.</p> <p>ASSISTANCE TO BIDDERS</p> <p>1) Any queries relating to the tender document and the terms and conditions contained therein should be addressed to the Tender Inviting Authority or the relevant contact person indicated in the tender.</p> <p>2) Any queries relating to the process of online bid submission or queries relating to CPP Portal in general may be directed to the 24x7 CPP Portal Helpdesk. The contact number for the helpdesk is Toll Free No. 1800 3070 2232 and Mobile Nos 91 7878007972 and 91 7878007973.</p> <p style="text-align: center;">****</p>

SECTION-XVI

SAFETY CODE

SECTION-XVI

SAFETY CODE

1. Suitable scaffolds should be provided for workmen for all works that cannot safely be done from the ground, or from solid construction except such short period work as can be done safely from ladders. When a ladder is used, an extra mazdoor shall be engaged for holding the ladder and if the ladder is used for carrying materials as well suitable footholds and hand-hold shall be provided on the ladder and the ladder shall be given an inclination not steeper than $\frac{1}{4}$ to 1 ($\frac{1}{4}$ horizontal and 1 vertical.)
2. Scaffolding of staging more than 3.6 m (12ft.) above the ground or floor, swung or suspended from an overhead support or erected with stationary support shall have a guard rail properly attached or bolted, braced and otherwise secured at least 90 cm. (3ft.) high above the floor or platform of such scaffolding or staging and extending along the entire length of the outside and ends there of with only such opening as may be necessary for the delivery of materials. Such scaffolding or staging shall be so fastened as to prevent it from swaying from the building or structure.
3. Working platforms, gangways and stairways should be so constructed that they should not sag unduly or unequally, and if the height of the platform or the gangway or the stairway is more than 3.6 m (12ft.) above ground level or floor level, they should be closely boarded, should have adequate width and should be suitably fastened as described in (2) above.
4. Every opening in the floor of a building or in a working platform shall be provided with suitable means to prevent the fall of person or materials by providing suitable fencing or railing whose minimum height shall be 90 cm. (3ft.)
5. Safe means of access shall be provided to all working platforms and other working places. Every ladder shall be securely fixed. No portable single ladder shall be over 9m. (30ft.) in length while the width between side rails in rung ladder shall in no case be less than 29 cm. ($11\frac{1}{2}$ ") for ladder upto and including 3 m. (10 ft.) in length. For longer ladders, this width should be increased at least $\frac{1}{4}$ " for each additional 30 cm. (1 foot) of length. Uniform step spacing of not more than 30 cm shall be kept. Adequate precautions shall be taken to prevent danger from electrical equipment. No materials on any of the sites or work shall be so stacked or placed as to cause danger or inconvenience to any person or the public. The contractor shall provide all necessary fencing and lights to protect the public from accident and shall be bound to bear the expenses of defence of every suit, action or other proceedings at law that may be brought by any person for injury sustained owing to neglect of the above precautions and to pay any damages and cost which may be awarded in any such suit, action or proceedings to any such person or which may, with the consent of the contractor, be paid to compensate any claim by any such person.
6. Excavation and Trenching - All trenches 1.2 m. (4ft.) or more in depth, shall at all times be supplied with at least one ladder for each 30 m. (100 ft.) in length or fraction thereof Ladder shall extend from bottom of the trench to at least 90 cm. (3ft.) above the surface of the ground. The side of the trenches which are

1.5 m. (5ft.) or more in depth shall be stepped back to give suitable slope or securely held by timber bracing, so as to avoid the danger of sides collapsing. The excavated materials shall not be placed within

1.5m. (5ft.) of the edges of the trench or half of the depth of the trench whichever is more. Cutting shall be done from top to bottom. Under no circumstances undermining or undercutting shall be done.

7. Demolition - Before any demolition work is commenced and also during the progress of the work,
 - i) All roads and open areas adjacent to the work site shall either be closed or suitably protected
 - ii) No electric cable or apparatus which is liable to be a source of danger or a cable or apparatus used by the operator shall remain electrically charged.
 - ii) All practical steps shall be taken to prevent danger to persons employed from risk of fire or explosion or flooding. No floor, roof or other part of the building shall be so overloaded with debris or materials as to render it unsafe.
8. All necessary personal safety equipment as considered adequate by the Employer should be kept available for the use of the person employed on the site and maintained in a condition suitable for immediate use, and the contractor should take adequate steps to ensure proper use of equipment by those concerned:- The following safety equipment shall invariably be provided.
 - i) Workers employed on mixing asphaltic materials, cement and lime mortars shall be provided with protective footwear and protective goggles.
 - ii) Those engaged in white washing and mixing or stacking of cement bags or any material which is injurious to the eyes, shall be provided with protective goggles.
 - iii) Those engaged in welding works shall be provided with welder's protective eye-shields.
 - iv) Stone breaker shall be provided with protective goggles and protective clothing and seated at sufficiently safe intervals.
 - v) When workers are employed in sewers and manholes, which are in active use, the contractors shall ensure that the manhole covers are opened and ventilated at least for an hour before the workers are allowed to get into the manholes, and the manholes so opened shall be cordoned off with suitable railing and provided with warning signals or boards to prevent accident to the public. In addition, the contractor shall ensure that the following safety measure are adhered to :-
 - a) Entry for workers into the line shall not be allowed except under supervision of the JE or any other higher officer.
 - b) At least 5 to 6 manholes upstream and downstream should be kept open for at least 2 to 3 hours before any man is allowed to enter into the manhole for working inside.
 - c) Before entry presence of Toxic gases should be tested by inserting wet lead acetate paper which changes colour in the presence of such gases and gives indication of their presence.
 - d) Presence of Oxygen should be verified by lowering a detector lamp into the manhole. In case, no Oxygen is found inside the sewer line, workers should be sent only with

Oxygen kit.

- e) Safety belt with rope should be provided to the workers. While working inside the manholes such rope should be handled by two men standing outside to enable him to be pulled out during emergency.
- f) The area should be barricaded or cordoned off by suitable means to avoid mishaps of any kind. Proper warning signs should be displayed for the safety of the public whenever cleaning works are undertaken during night or day.
- g) No smoking or open flames shall be allowed near the blocked manhole being cleaned.
- h) The malba obtained on account of cleaning of blocked manholes and sewer lines should be immediately removed to avoid accidents on account of slippery nature of the malba.
- i) Workers should not be allowed to work inside the manhole continuously. He should be given rest intermittently. The Employer may decide the time up to which a worker may be allowed to work continuously inside the manhole.
- j) Gas masks with Oxygen Cylinder should be kept at site for use in emergency.
- k) Air-blowers should be used for flow of fresh air through the manholes. Whenever called for portable air blowers are recommended for ventilating the manholes. The Motors for these shall be vapour proof and of totally enclosed type. Non sparking gas engines also could be used but they should be placed at least 2 metres away from the opening and on the leeward side protected from wind so that they will not be a source of friction on any inflammable gas that might be present.
- l) The workers engaged for cleaning the manholes/sewers should be properly trained before allowing to work in the manhole.
- m) The workers shall be provided with Gumboots or non sparking shoes bump helmets and gloves non sparking tools safety lights and gas masks and portable air blowers (when necessary). They must be supplied with barrier cream for anointing the limbs before working inside the sewer lines.
- n) Workmen descending a manhole shall try each ladder stop or rung carefully before putting his full weight on it to guard against insecure fastening due to corrosion of the rung fixed to manhole well.
- o) If a man has received a physical injury, he should be brought out of the sewer immediately and adequate medical aid should be provided to him.
- p) The extent to which these precautions are to be taken depend on individual situation but the decision of the Employer regarding the steps to be taken in this regard in an individual case will be final.
- vi) The Contractor shall not employ men and women below the age of 18 years on the work of painting with products containing lead in any form. Wherever men above the age of 18 are employed on the work of lead painting, the following precaution should be taken:-
 - a) No paint containing lead or lead products shall be used except in the form of paste or ready made paint.
 - b) Suitable face masks should be supplied for use by the workers when paint is applied in the form of spray or a surface having lead paint is dry rubbed and scraped.

- c) Overalls shall be supplied by the contractors to the workmen and adequate facilities shall be provided to enable the working painters to wash during and on the cessation of work.
- 9 The Contractor shall not employ women and men below the age of 18 on the work of painting with product containing lead in any form. wherever men above the age of 18 are employed on the work of lead painting, the following principles must be observed for such use :
- (i) White lead, sulphate of lead or product containing these pigment, shall not be used in painting operation except in the form of pastes or paint ready for use.
 - ii) Measures shall be taken, wherever required in order to prevent danger arising from the application of paint in the form of spray.
 - iii) Measures shall be taken, wherever practicable, to prevent danger arising out of from dust caused by dry rubbing down and scraping.
 - iv) Adequate facilities shall be provided to enable working painters to wash during and on cessation of work.
 - v) Overall shall be worn by working painters during the whole of working period.
 - vi) Suitable arrangement shall be made to prevent clothing put off during working hours being spoiled by painting materials.
 - vii) Cases of lead poisoning and suspected lead poisoning shall be notified and shall be subsequently verified by medical man appointed by the Employer.
 - viii) The Employer may require, when necessary medical examination of workers.
 - ix) Instructions with regard to special hygienic precautions to be taken in the painting trade shall be distributed to working painters.
10. When the work is done near any place where there is risk of drowning, all necessary equipments should be provided and kept ready for use and all necessary steps taken for prompt rescue of any person in danger and adequate provision, should be made for prompt first aid treatment of all injuries likely to be obtained during the course of the work.
11. Use of hoisting machines and tackle including their attachments, anchorage and supports shall conform to the following standards or conditions :-
- i) (a) These shall be of good mechanical construction, sound materials and adequate strength and free from patent defects and shall be kept repaired and in good working order.
 - (b) Every rope used in hoisting or lowering materials or as a means of suspension shall be of durable quality and adequate strength, and free from patent defects.
 - ii) Every crane driver or hoisting appliance operator, shall be properly qualified and no person under the age of 21 years should be in charge of any hoisting machine including any scaffolding winch or give signals to operator.
 - iii) In case of every hoisting machine and of every chain ring hook, shackle swivel and pulley block used in hoisting or as means of suspension, the safe working load shall be ascertained by adequate means. Every hoisting machine and all gear referred to above shall be plainly marked with the safe working load. In case of a hoisting machine having a variable safe working load each safe working load and the condition under which it is applicable shall be clearly indicated. No part of any machine or any gear referred to

above in this paragraph shall be loaded beyond the safe working load except for the purpose of testing.

- iv) In case of departmental machines, the safe working load shall be notified by the Electrical Employer. As regards contractor's machines the contractors shall notify the safe working load of the machine to the Employer whenever he brings any machinery to site of work and get it verified by the Electrical Engineer concerned.
12. Motors, gearing, transmission, electric wiring and other dangerous parts of hoisting appliances should be provided with efficient safeguards. Hoisting appliances should be provided with such means as will reduce to the minimum the risk of accidental descent of the load. Adequate precautions should be taken to reduce to the minimum the risk of any part of a suspended load becoming accidentally displaced. When workers are employed on electrical installations which are already energized, insulating mats, wearing apparel, such as gloves, sleeves and boots as may be necessary should be provided. The worker should not wear any rings, watches and carry keys or other materials which are good conductors of electricity.
 13. All scaffolds, ladders and other safety devices mentioned or described herein shall be maintained in safe condition and no scaffold, ladder or equipment shall be altered or removed while it is in use. Adequate washing facilities should be provided at or near places of work.
 14. These safety provisions should be brought to the notice of all concerned by display on a notice board at a prominent place at work spot. The person responsible for compliance of the safety code shall be named therein by the contractor.
 15. To ensure effective enforcement of the rules and regulations relating to safety precautions the arrangements made by the contractor shall be open to inspection by the Labour Officer or Employer of the department or their representatives.
 1. Notwithstanding the above clauses from (1) to (15) there is nothing in these to exempt the contractor from the operations of any other Act or Rule in force in the Republic of India.

WP(C) 36/2009

ITEM NO.11

COURT NO.1

SECTION PIL

S U P R E M E C O U R T O F I N D I A
R E C O R D O F P R O C E E D I N G S

WRIT PETITION (CIVIL) NO(s). 36 OF 2009

IN RE: MEASURES FOR PREVENTION OF FATAL
ACCIDENTS OF SMALL CHILDREN DUE TO THEIR
FALLING INTO ABANDONED BORE WELLS AND TUBE WELLS

Petitioner(s)

VERSUS

UNION OF INDIA & ORS.

Respondent(s)

(With office report)

Date: 11/02/2010

This Petition was called on for hearing today.

CORAM :

HON'BLE THE CHIEF JUSTICE
HON'BLE DR. JUSTICE B.S. CHAUHAN
HON'BLE MR. JUSTICE C.K. PRASAD

Mr. Paramjit Singh Patwalia, Sr. Adv.

(A.C.)
For Petitioner(s)

For Respondent(s)

Ms. Indira JaiSing, ASG
Mr. Ashok Bhan, Adv.
Ms. Sadhna Sandhu, Adv.
Mr. C.K. Sharma, Adv.
Mr. D.S. Mahra, Adv.

For State of Haryana

Mr. Manjit Singh, AAG for Haryana
Mr. Kamal Mohan Gupta, Adv.
Ms.Reeta Chaudhary, Adv.
Mr. Gaurav Teotia,Adv.

For State of Punjab

Mrs. JayshreeAnand, AAG for Punjab
Mr. K.K. Mahalik, Adv.
Mrs. Noor Jahan, Adv.
Mr. Kuldeep Singh, Adv.

For State of Raj.

Dr. Manish Singhvi, AAG for Rajasthan
Mr. Devanshu Kumar Devesh, Adv.
Mr. Milind Kumar, Adv.
Mr. T. Harish Kumar, Adv.

For State of U.P.

Mr. Shail Kumar Dwivedi, AAG for U.P.
Mr. Manoj Kr. Dwivedi, adv.
Ms. Vandana Mishra, Adv.
Mr. Ashutosh Kr. Sharma, Adv.
Mr. GunnamVenkateswara Rao, Adv.

For State of T.N.

Ms. Promila, adv.
Mr. S. Thananjayan, Adv.

UPON hearing counsel the Court made the following O R D E R

Certain safety measures/guidelines have been given in the signed order which are to be observed by all the States. The guidelines given in the signed order Shall be given wide publicity through the national television channels. A copy of this order be sent to the Chief Secretaries of all the States/Union Territories who shall forward the same to the District Collectors of all Districts of their respective State.

For further directions post this matter after 12 weeks.

(Ajay Kr. Jain)
Court Master

(Veera Verma)
Court Master

(Signed order is placed on the file)

IN THE SUPREME COURT OF INDIA
CIVIL ORIGINAL JURISDICTION

WRIT PETITION(C)NO.36 OF 2009

In Re: Measures for Prevention of Fatal Accidents of Small Children Due to Their Falling Into Abandoned Bore Wells and Tube Wells	Petitioner
	Versus	
Union of India &Ors.	Respondents

ORDER

Heard the learned Amicus Curiae and the learned Addl. Solicitor General appearing for the Union of India.

It has been brought to the notice of this Court that in a number of cases children had been trapped and fallen into bore wells and tube wells or abandoned wells. These reports have been coming from various States. Accordingly, we took suo motu initiative and issued notice to the various States to take immediate measures to prevent such kind of incidents.

The Union of India has filed its counter affidavit giving certain guidelines to be followed by the States.

We have perused the affidavit and the guidelines suggested by the Union of India.

Having regard to the number of incidents that have taken place during the recent past and immediate need for preventing such incidents in future, we direct that the following safety measures/guidelines are to be observed by all the States :-

(i)"The owner of the land/premises, before taking any steps for constructing bore well/ tube well must inform in writing at least 15 days in advance to the concerned authorities in the area, i.e., District Collector/ District Magistrate/Sarpanch of the Gram Panchayat/ concerned officers of the Department of Ground Water/ Public Health/ Municipal Corporation, as the case may be, about the construction of bore well/tube well.

(ii)Registration of all the drilling agencies,viz., Govt./Semi Govt./Private etc. should be mandatory with the district administration.

(iii)Erection of signboard at the time of construction near the well with the following details :-

a)Complete address of the drilling agency at the time of construction/
rehabilitation of well. (b)Complete address of the user agency/ owner
of the well.

(iv)Erection of barbed wire fencing or any other suitable barrier around the well during construction.

(v) Construction of cement/concrete platform measuring 0.50 x 0.50x 0.60 meter (0.30 meter above ground level and 0.30 meter below ground level) around the well casing.

(vi) Capping of well assembly by welding steel plate or by providing a strong cap to be fixed to the casing pipe with bolts & nuts.

(vii) In case of pump repair, the tube well should not be left uncovered.

(viii) Filling of mud pits and channels after completion of works.

(ix) Filling up abandoned borewells by clay/sand /boulders/pebbles/drill cuttings etc. from bottom to ground level.

(x) On completion of the drilling operations at a particular location, the ground conditions are to be restored as before the start of drilling.

(xi) District Collector should be empowered to verify that the above guidelines are being followed and proper monitoring check about the status of boreholes/tubewells are being taken care through the concerned State/Central Government agencies.

(xii) District/Block/Village wise status of bore wells/tubewells drilled viz. No. of wells in use, No. of abandoned bore wells/tube wells found open, No. of abandoned borewells/tubewells properly filled up to ground level and balance number of abandoned borewells/tubewells to be filled up to ground level is to be maintained at District Level.

In rural areas, the monitoring of the above is to be done through Village Sarpanch and the Executive from the Agriculture Department.

In case of urban areas, the monitoring of the above is to be done through Junior Engineer and the Executive from the concerned Department of Ground Water/Public Health/ Municipal Corporation etc.

(xiii) If a borewell/tubewell is 'Abandoned' at any stage, a certificate from the concerned department of Ground Water/Public health/Municipal Corporation/Private contractor etc. must be obtained by the aforesaid agencies that the 'Abandoned' borewell/tubewell is properly filled upto the ground level. Random inspection of the abandoned wells is also to be done by the Executive of the concern agency/department. Information on all such data on the above are to be maintained in the District Collector/ Block Development Office of the State.

The guidelines abovementioned shall be given wide publicity through the national television channels. A copy of this order be sent to the Chief Secretaries of all the States/Union Territories who shall forward the same to the District Collectors of all Districts of their respective State for further directions post this matter after 12 weeks.

.....CJI.

.....J.
(Dr. B.S. CHAUHAN)

.....J. (C.K. PRASAD)

NEW DELHI;
FEBRUARY 11, 2010

SECTION- XVII

MODEL RULES FOR THE PROTECTION OF HEALTH AND SANITARY ARRANGEMENTS FOR WORKERS

SECTION- XVII

MODEL RULES FOR THE PROTECTION OF HEALTH AND SANITARY ARRANGEMENTS FOR WORKERS

1. APPLICATION

These rules shall apply to all buildings and construction works in which twenty or more workers are ordinarily employed or are proposed to be employed in any day during the period during which the contract work is in progress.

2. DEFINITION

Work place means a place where twenty or more workers are ordinarily employed in connection with construction work on any day during the period during which the contract work is in progress.

3. FIRST-AID FACILITIES

- i) At every work place there shall be provided and maintained, so as to be easily accessible during working hours, first-aid boxes at the rate of not less than one box for 150 contract labour or part thereof ordinarily employed.
- ii) The first-aid box shall be distinctly marked with a red cross on white back ground and shall contain the following equipment:-
 - a) For work places in which the number of contract labour employed does not exceed 50-Each first-aid box shall contain the following equipments :-
 1. 6 small sterilized dressings.
 2. 3 medium size sterilized dressings.
 3. 3 large size sterilized dressings.
 4. 3 large sterilized burn dressings.
 5. 1 (30 ml.) bottle containing a two per cent alcoholic solution of iodine.
 6. 1 (30 ml.) bottle containing salvolatile having the dose and mode of administration indicated on the label.
 7. 1 snakebite lancet.
 8. 1 (30 gms.) bottle of potassium permanganate crystals.
 9. 1 pair scissors.
 10. 1 copy of the first-aid leaflet issued by the Director General, Factory Advice Service and Labour Institutes, Government of India.
 11. 1 bottle containing 100 tablets (each of 5 gms.) of aspirin.
 12. Ointment for burns.
 13. A bottle of suitable surgical antiseptic solution.
 - b) For work places in which the number of contract labour

exceed 50. Each first-aid box shall contain the following equipments.

1. 12 small sterilized dressings.
2. 6 medium size sterilized dressings.
3. 6 large size sterilized dressings.
4. (15 gms.) Packets sterilized cotton wool.
5. 1 (60 ml.) bottle containing two per cent alcoholic solution iodine.
6. 1 (60 ml.) bottle containing salvolatile having the dose and mode of administration indicated on the label.
7. 1 rolls of adhesive plaster.
8. 1 snake bite lancet.
9. 1 (30 gms.) bottle of potassium permanganate crystals.
10. 1 pair scissors.
11. 1 copy of the first-aid leaflet issued by the Director General Factory Advice Service and Labour Institutes /Government of India.
12. A bottle containing 100 tablets (each of 5 gms.) of aspirin.
13. Ointment for burns.
14. A bottle of suitable surgical antiseptic solution.

- iii) Adequate arrangements shall be made for immediate recoupment of the equipment when necessary.
- iv) Nothing except the prescribed contents shall be kept in the First-aid box.
- v) The first-aid box shall be kept in charge of a responsible person who shall always be readily available during the working hours of the work place.
- vi) A person in charge of the First-aid box shall be a person trained in First-aid treatment, in the work places where the number of contract labour employed is 150 or more.
- vii) In work places where the number of contract labour employed is 500 or more and hospital facilities are not available within easy distance from the works. First-aid posts shall be established and run by a trained compounder. The compounder shall be on duty and shall be available at all hours when the workers are at work.
- viii) Where work places are situated in places which are not towns or cities, a suitable motor transport shall be kept readily available to carry injured person or person suddenly taken ill to the nearest hospital.

4. DRINKING WATER

- i) In every work place, there shall be provided and maintained at suitable places, easily accessible to labour, a sufficient supply of cold water fit for drinking.
- ii) Where drinking water is obtained from an Intermittent public water supply, each work place shall be provided with storage where such drinking water shall be stored.

- iii) Every water supply or storage shall be at a distance of not less than 50 feet from any latrine drain or other source of pollution. Where water has to be drawn from an existing well which is within such proximity of latrine, drain or any other source of pollution, the well shall be properly chlorinated before water is drawn from it for drinking. All such wells shall be entirely closed in and be provided with a trap door which shall be dust and waterproof.
- iv) A reliable pump shall be fitted to each covered well, the trap door shall be kept locked and opened only for cleaning or inspection which shall be done at least once a month.

5. WASHING FACILITIES

- i) In every work place adequate and suitable facilities for washing shall be provided and maintained for the use of contract labour employed therein.
- ii) Separate and adequate cleaning facilities shall be provided for the use of male and female workers.
- iii) Such facilities shall be conveniently accessible and shall be kept in clean and hygienic condition.

6. LATRINES AND URINALS

- i) Latrines shall be provided in every work place on the following scale namely :-
 - a) Where female are employed there shall be at least one latrine for every 25 females.
 - b) Where males are employed, there shall be at least one latrine for every 25 males.

Provided that where the number of males or females exceeds 100, it shall be sufficient if there is one latrine for 25 males or females as the case may be up to the first 100, and one for every 50 thereafter.

- ii) Every latrine shall be under cover and so partitioned off as to secure privacy, and shall have a proper door and fastenings.
- iii) Construction of latrines : The inside walls shall be constructed of masonry or some suitable heat-resisting nonabsorbent materials and shall be cement washed inside and outside at least once a year, Latrines shall not be of a standard lower than borehole system.
- iv) a) Where workers of both sexes are employed, there shall be displayed outside each block of
 - latrine and urinal, a notice in the language understood by the majority of the workers "For Men only" or "For Women Only" as the case may be.
 - b) The notice shall also bear the figure of a man or of a woman, as the case may be.
- v) There shall be at least one urinal for male workers up to 50 and one for female workers up to fifty employed at a time, provided that where the number of male or female workmen, as the case may be exceeds 500, it shall be sufficient if there is one urinal for every 50 males or females up to the first 500 and one for every 100 or

part thereafter.

- vi) a) The latrines and urinals shall be adequately lighted and shall be maintained in a clean and sanitary condition at all times.
b) Latrines and urinals other than those connected with a flush sewage system shall comply with the requirements of the Public Health Authorities.
- vii) Water shall be provided by means of tap or otherwise so as to be conveniently accessible in or near the latrines and urinals.
- viii) Disposal of excreta :- Unless otherwise arranged for by the local sanitary authority, arrangements for proper disposal of excreta by incineration at the work place shall be made by means of a suitable incinerator. Alternately excreta may be disposed of by putting a layer of night soil at the bottom of a pucca tank prepared for the purpose and covering it with a 15 cm. layer of waste or refuse and then covering it with a layer of earth for a fortnight (when it will turn to manure).
- (ix) The contractor shall at his own expense, carry out all instructions issued to him by the Employer to effect proper disposal of night soil and other conservancy work in respect of the contractor's workmen or employees on the site. The contractor shall be responsible for payment of any charges which may be levied by Municipal or Cantonment Authority for execution of such on his behalf.

7. PROVISION OF SHELTER DURING REST

At every place there shall be provided, free of cost, four suitable sheds, two for meals and the other two for rest separately for the use of men and women labour. The height of each shelter shall not be less than 3 metres (10 ft.) from the floor level to the lowest part of the roof. These shall be kept clean and the space provided shall be on the basis of 0.6 sq.m. (6 sft) per head.

Provided that the Employer may permit subject to his satisfaction, a portion of the building under construction or other alternative accommodation to be used for the purpose.

8. CRECHES

- i) At every work place, at which 20 or more women worker are ordinarily employed, there shall be provided two rooms of reasonable dimensions for the use of their children under the age of six years. One room shall be used as a play room for the children and the other as their bedroom.
- ii) The rooms shall be provided with suitable and sufficient openings for light and ventilation. There shall be adequate provision of sweepers to keep the places clean.
- iii) The contractor shall supply adequate number of toys and games in the play room and sufficient number of cots and beddings in the bed room.
- iv) The contractor shall provide one ayaa to look after the children in the creche when the number of women workers does not exceed 50 and two when the number of women workers exceed 50.
- v) The use of the rooms earmarked as creches shall be restricted to children, their attendants and mothers of the children.

9. CANTEENS

- i) In every work place where the work regarding the employment of contract labour is likely to continue for six months and where in contract labour numbering one hundred or more are ordinarily employed, an adequate canteen shall be provided by the contractor for the use of such contract labour.
- ii) The canteen shall be maintained by the contractor in an efficient manner.
- iii) The canteen shall consist of at least a dining hall, kitchen, storeroom, pantry and washing places separately for workers and utensils.
- iv) The canteen shall be sufficiently lighted at all times when any person has access to it.
- v) The floor shall be made of smooth and impervious materials and inside walls shall be lime-washed or colour washed at least once in each year.
Provided that the inside walls of the kitchen shall be lime-washed every four months.
- vi) The premises of the canteen shall be maintained in a clean and sanitary condition.
- vii) Waste water shall be carried away in suitable covered drains and shall not be allowed to accumulate so as to cause a nuisance.
- viii) Suitable arrangements shall be made for the collection and disposal of garbage.
- ix) The dining hall shall accommodate at a time 30 per cent of the contract labour working at a time.
- x) The floor area of the dining hall, excluding the area occupied by the service counter and any furniture except tables and chairs shall not be less than one square meter (10 sft) per diner to be accommodated as prescribed in sub-Rule 9.
- xi) a) A portion of the dining hall and service counter shall be partitioned off and reserved for
 women workers in proportion to their number.
 b) Washing places for women shall be separate and screened to secure privacy.
- xii) Sufficient tables stools, chair or benches shall be available for the number of diners to be accommodated as prescribed in sub-Rule 9.
- xiii) a) 1. There shall be provided and maintained sufficient utensils crockery, furniture and any other equipments necessary for the efficient running of the canteen.
 2. The furniture utensils and other equipment shall be maintained in a clean and hygienic condition.
 b) 1. Suitable clean clothes for the employees serving in the canteen shall be provided and maintained.
 2. A service counter, if provided, shall have top of smooth and impervious material.
 3. Suitable facilities including an adequate supply of hot water shall be

provided for the cleaning of utensils and equipments.

- xiv) The food stuffs and other items to be served in the canteen shall be in conformity with the normal habits of the contract labour.
- xv) The charges for food stuffs, beverages and any other items served in the canteen shall be based on 'No profit, No loss' and shall be conspicuously displayed in the canteen.
- xvi) In arriving at the price of foodstuffs, and other article served in the canteen, the following items shall not be taken into consideration as expenditure namely:-
 - a) The rent of land and building.
 - b) The depreciation and maintenance charges for the building and equipments provided for the canteen.
 - c) The cost of purchase, repairs and replacement of equipments including furniture, crockery, cutlery and utensils.
 - d) The water charges and other charges incurred for lighting and ventilation.
 - e) The interest and amounts spent on the provision and maintenance of equipments provided for the canteen.
- xvii) The accounts pertaining to the canteen shall be audited once every 12 months by registered accountants and auditors.

10. ANTI-MALARIAL PRECAUTIONS

The contractor shall at his own expense, conform to all anti-malarial instructions given to him by the Employer including the filling up of any borrow pits which may have been dug by him.

- 11. The above rules shall be incorporated in the contracts and in notices inviting tenders and shall form an integral part of the contracts.

12. AMENDMENTS

Government may, from time to time, add to or amend these rules and issue directions - it may consider necessary for the purpose of removing any difficulty which may arise in the administration thereof.

SECTION- XVIII
CONTRACTOR'S LABOUR REGULATIONS

SECTION- XVIII

CONTRACTOR'S LABOUR REGULATIONS

1. SHORT TITLE

These regulations may be called Contractors Labour Regulations.

2. DEFINITIONS

- i) **Workman** means any person employed by contractor directly or indirectly through a subcontractor to do any skilled, semiskilled or unskilled manual, supervisory, technical or clerical work for hire or reward, whether the terms of employment are expressed or implied but does not include any person :-
- a) Who is employed mainly in a managerial or administrative capacity : or
 - b) Who, being employed in a supervisory capacity draws wages exceeding five hundred rupees per mensem or exercises either by the nature of the duties attached to the office or by reason of powers vested in him, functions mainly of managerial nature : or
 - c) Who is an out worker, that is to say, person to whom any article or materials are given out by or on behalf of the principal employers to be made up, cleaned, washed, altered, ornamental finished, repaired, adopted or otherwise processed for sale for the purpose of the trade or business of the principal employers and the process is to be carried out either in the home of the out worker or in some other premises, not being premises under the control and management of the principal employer.

No person below the age of 14 years shall be employed to act as a workman.

- ii) **Fair Wages** means wages whether for time or piece work fixed and notified under the provisions of the Minimum Wages Act from time to time.
 - iii) **Contractors** shall include every person who undertakes to produce a given result other than a mere supply of goods or articles of manufacture through contract labour or who supplies contract labour for any work and includes a subcontractor.
 - iv) **Wages** shall have the same meaning as defined in the Payment of Wages Act.
3. i) Normally working hours of an adult employee should not exceed 9 hours a day. The working day shall be so arranged that inclusive of interval for rest, if any, it shall not spread over more than 12 hours on any day.
- ii) When an adult worker is made to work for more than 9 hours on any day or for more than 48 hours in any week, he shall be paid over time for the extra hours put in by him at double the ordinary rate of wages.
 - iii) a) Every worker shall be given a weekly holiday normally on a Sunday, in

accordance with

the provisions of the Minimum Wages (Central) Rules 1960 as amended from time to time irrespective of whether such worker is governed by the Minimum Wages Act or not.

- b) Where the minimum wages prescribed by the Government under the Minimum Wages Act are not inclusive of the wages for the weekly day of rest, the worker shall be entitled to rest day wages at the rate applicable to the next preceding day, provided he has worked under the same contractor for a continuous period of not less than 6 days.
- c) Where a contractor is permitted by the Employer to allow a worker to work on a normal weekly holiday, he shall grant a substituted holiday to him for the whole day on one of the five days immediately before or after the normal weekly holiday and pay wages to such worker for the work performed on the normal weekly holiday at overtime rate.

4. DISPLAY OF NOTICE REGARDING WAGES ETC.

The contractor shall before he commences his work on contract, display and correctly maintain and continue to display and correctly maintain in a clear and legible condition in conspicuous places on the work, notices in English and in the local Indian languages spoken by the majority of the workers giving the minimum rates of wages fixed under Minimum Wages Act, the actual wages being paid, the hours of work for which such wage are earned, wages periods, dates of payments of wages and other relevant information..

5. PAYMENT OF WAGES

- i) The contractor shall fix wage periods in respect of which wages shall be payable.
- ii) No wage period shall exceed one month.
- iii) The wages of every person employed as contract labour in an establishment or by a contractor where less than one thousand such persons are employed shall be paid before the expiry of seventh day and in other cases before the expiry of tenth day after the last day of the wage period in respect of which the wages are payable.
- iv) Where the employment of any worker is terminated by or on behalf of the contractor the wages earned by him shall be paid before the expiry of the second working day from the date on which his employment is terminated.
- v) All payment of wages shall be made on a working day at the work premises and during the working time and on a date notified in advance and in case the work is completed before the expiry of the wage period, final payment shall be made within 48 hours of the last working day.
- vi) Wages due to every worker shall be paid to him direct or to other person authorized by him in this behalf.
- vii) All wages shall be paid in current coin or currency or in both.
- viii) Wages shall be paid without any deductions of any kind except those specified by the Central Government by general or special order in this behalf or permissible under the Payment of Wages Act 1956.
- ix) A notice showing the wages period and the place and time of disbursement of wages

shall be displayed at the place of work and a copy sent by the contractor to the Employer under acknowledgment.

- x) It shall be the duty of the contractor to ensure the disbursement of wages in the presence of the Engineer or any other authorized representative of the Employer who will be required to be present at the place and time of disbursement of wages by the contractor to workmen.
- xi) The contractor shall obtain from the Junior Engineer or any other authorized representative of the Employer as the case may be, a certificate under his signature at the end of the entries in the "Register of Wages" or the "Wage-cum-Muster Roll" as the case may be in the following form:-

"Certified that the amount shown in column No..... has been paid to the workman concerned in my presence on at"

6. FINES AND DEDUCTIONS WHICH MAY BE MADE FROM WAGES

- (i) The wages of a worker shall be paid to him without any deduction of any kind except the following :-
 - (a) Fines
 - (b) Deductions for absence from duty i.e. from the place or the places where by the terms of his employment he is required to work. The amount of deduction shall be in proportion to the period for which he was absent.
 - (c) Deduction for damage to or loss of goods expressly entrusted to the employed person for custody, or for loss of money or any other deduction which he is required to account, where such damage or loss is directly attributable to his neglect or default.
 - (d) Deduction for recovery of advances or for adjustment of overpayment of wages, advances granted shall be entered in a register.
 - (e) Any other deduction which the Central Government may from time to time allow.
- (ii) No fines should be imposed on any worker save in respect of such acts and omissions on his part as have been approved of by the Chief Labour Commissioner.
Note :- An approved list of Acts and Omissions for which fines can be imposed is enclosed at Appendix-I
- (iii) No fine shall be imposed on a worker and no deduction for damage or loss shall be made from his wages until the worker has been given an opportunity of showing cause against such fines or deductions.
- (iv) The total amount of fine which may be imposed in any one wage period on a worker shall not exceed an amount equal to three paise in a rupee of the total wages, payable to him in respect of that wage period.
- (v) No fine imposed on any worker shall be recovered from him by instalment, or after the expiry of sixty days from the date on which it was imposed.
- (vi) Every fine shall be deemed to have been imposed on the day of the act or omission in respect of which it was imposed.

7. LABOUR RECORDS

- (i) The contractor shall maintain a **Register of persons employed** on work on contract in Form XIII of the CL (R&A) Central Rules 1971
- (ii) The contractor shall maintain a **Muster Roll** register in respect of all workmen employed by him on the work under Contract in Form XVI of the CL (R&A) Rules 1971.
- (iii) The contractor shall maintain a **Wage Register** in respect of all workmen employed by him on the work under contract in Form XVII of the CL (R&A) Rules 1971
- (iv) **Register of accident** - The contractor shall maintain a register of accidents in such form as maybe convenient at the work place but the same shall include the following particulars:
 - a) Full particulars of the labourers who met with accident.
 - b) Rate of Wages.
 - c) Sex
 - d) Age
 - e) Nature of accident and cause of accident.
 - f) Time and date of accident.
 - g) Date and time when admitted in Hospital.
 - h) Date of discharge from the Hospital.
 - i) Period of treatment and result of treatment.
 - j) Percentage of loss of earning capacity and disability as assessed by Medical Officer.
 - k) Claim required to be paid under Workmen's Compensation Act.
 - l) Date of payment of compensation.
 - m) Amount paid with details of the person to whom the same was paid.
 - n) Authority by whom the compensation was assessed.
 - o) Remarks
- v) The contractor shall maintain a **Register of Fines** in the Form XII of the CL (R&A) Rules 1971

The contractor shall display in a good condition and in a conspicuous place of work the approved list of acts and omissions for which fines can be imposed
- vi) The contractor shall maintain a **Register of deductions for damage or loss** in Form XX of the CL (R&A) Rules 1971.
- vii) The contractor shall maintain a **Register of Advances** in Form XXIII of the CL (R&A) Rules 1971.
- viii) The contractor shall maintain a **Register of Overtime** in Form XXIII of the CL (R&A) Rules 1971.

8. ATTENDANCE CARD-CUM-WAGE SLIP

- i) The contractor shall issue an **Attendance card-cum-wage slip** to each workman

employed by him.

- ii) The card shall be valid for each wage period.
- iii) The contractor shall mark the attendance of each workman on the card twice each day, once at the commencement of the day and again after the rest interval, before he actually starts work.
- iv) The card shall remain in possession of the worker during the wage period under reference.
- v) The contractor shall complete the wage slip portion on the reverse of the card at least a day prior to the disbursement of wages in respect of the wage period under reference.
- vi) The contractor shall obtain the signature or thumb impression of the worker on the wage slip at the time of disbursement of wages and retain the card with himself.

9. EMPLOYMENT CARD

The contractor shall issue an **Employment Card** in Form XIV of the CL (R&A) Central Rules 1971 to each worker within three days of the employment of the worker.

10. SERVICE CERTIFICATE

On termination of employment for any reason whatsoever the contractor shall issue to the workman whose services have been terminated, a **Service certificate** in Form XV of the CL (R&A) Central Rules 1971.

11. PRESERVATION OF LABOUR RECORDS

All records required to be maintained under Regulations Nos. 6&7 shall be preserved in original for a period of three years from the date of last entries made in them and shall be made available for inspection by the Employer or Labour Officer.

12. POWER OF LABOUR OFFICER TO MAKE INVESTIGATIONS OR ENQUIRY

The Labour Officer or any person authorized by Central Government on their behalf shall have power to make enquires with a view to ascertaining and enforcing due and proper observance of Fair Wage Clauses and the Provisions of these Regulations. He shall investigate into any complaint regarding the default made by the contractor or subcontractor in regard to such provision.

13. REPORT OF LABOUR OFFICER

The Labour Officer or other persons authorized as aforesaid shall submit a report of result of his investigation or enquiry to the Employer indicating the extent, if any, to which the default has been committed with a note that necessary deductions from the contractor's bill be made and the wages and other dues be paid to the labourers concerned. In case an appeal is made by the contractor under Clause 13 of these regulations, actual payment to labourers will be made by the Engineer after the Employer has given his decision on such appeal.

- i) The Engineer shall arrange payments to the labour concerned within 45 days from the receipt of the report from the Labour Officer or the Employer as the case may be.

14. APPEAL AGAINST THE DECISION OF LABOUR OFFICER

Any person aggrieved by the decision and recommendations of the Labour Officer or other person so authorised may appeal against such decision to the Employer within 30 days

from the date of decision, forwarding simultaneously a copy of his appeal to the Engineer concerned but subject to such appeal, the decision of the officer shall be final and binding upon the contractor.

15. PROHIBITION REGARDING REPRESENTATION THROUGH LAWYER

- i) A workman shall be entitled to be represented in any investigation or enquiry under these regulations by:-
 - a) An officer of a registered trade union of which he is a member.
 - b) An officer of a federation of trade unions to which the trade union referred to in clause (a) is affiliated.
 - c) Where the employer is not a member of any registered trade union, by an officer of a registered trade union, connected with the industry in which the worker is employed or by any other workman employed in the industry in which the worker is employed.

- ii) An employer shall be entitled to be represented in any investigation or enquiry under these regulations by :-
 - a) An officer of an association of employers of which he is a member.
 - b) An officer of a federation of associations of employers to which association referred to in clause (a) is affiliated.
 - c) Where the employers is not a member of any association of employers, by an officer of association of employer connected with the industry in which the employer is engaged or by any other employer, engaged in the industry in which the employer is engaged.

- (iii) No party shall be entitled to be represented by a legal practitioner in any investigation or enquiry under these regulations.

16. INSPECTION OF BOOKS AND SLIPS

The contractor shall allow inspection of all the prescribed labour records to any of his workers or to his agent at a convenient time and place after due notice is received or to the Labour Officer or any other person, authorized by the Central Government on his behalf.

17. SUBMISSIONS OF RETURNS

The contractor shall submit periodical returns as may be specified from time to time.

18. AMENDMENTS

The Central Government may from time to time add to or amend the regulations and on any question as to the application/Interpretation or effect of those regulations the decision of the Employer shall be final.

(Note: Necessary Formats in which records are to be maintained and returns to be submitted shall be provided by the Employer.)

SECTION- XIX
CHECKLIST

SECTION- XIX CHECKLIST

(Please ensure that you have serially numbered each and every page of scanned documents forming your bid and furnished following documents in the manner prescribed mentioning the page number(s) of your bid in appropriate box)

This Checklist should be the first document of your bid numbered as page 1.

CHECKLIST MUST BE FILLED & SUBMITTED BY THE BIDDER

Clause No.	Duly Self Attested following documents	Reference Page No(s) where the documents are uploaded
Section II (ITB Clause 2.9)	(a) Copy of valid registration/enlistment with the respective authorities (Reference: clause 2.2 of eligibility criteria). (Sl.No.1 of Section XI)	
	(b) In case of a consortium, certified copy of the agreement between various partners. (Reference : Clause 2.2 of eligibility criteria)	
	(c) Scanned copy of undertaking of having employed the ground water professional during execution of work. (Reference : Clause 2.2 of eligibility criteria)	
	(d) Scanned copy of undertaking as per eligibility criteria 2.2 (d).	
	(e) Current Available Bid Capacity of Bidder duly certified by CA (as per clause 2.2 (i)) with documentary proof of "A value i.e. Maximum value of engineering works executed during any last five year" and "B value i.e. value of existing commitments and ongoing works to be completed in the next "N" years."	
	(f) Turnover for last three years duly certified by Chartered Accountant. (Reference: Clause 2.3 of eligibility criteria). (Sl.No.2 of Section XI)	
	(g) Details of works completed as per table at Sl. No.3 (a) of Section XI. (Reference : Clause 2.4 of eligibility criteria) along with documentary proof	
	(h) Details of payment received for completed works alongwith documentary proof as per table at Sl. No 3(B) of Section XI (Reference : Clause 2.4 of eligibility criteria)	
	(i) Scanned copy of undertaking as per eligibility criteria 2.5	
	(j) Details of Borewells/Tubewells constructed as per table at Sl. No.4 of Section XI. (Reference : Clause 2.6 of eligibility criteria) along with documentary proof.	
	(k) Scanned copy of EMD: As per clause 13 of Section II Instructions to Bidders.	
	(l) Scanned copy of tender fee.	
	(m) Scanned copy of Tender Acceptance letter: As per format in Section XIV	
	(n) Undertaking as per clause 2.5 of eligibility criteria	
(o) The proof of supply in respect of DWLR and telemetry as per supply order along with delivery challan and Commissioning report/ Installation report/ Performance certificate in respect of successful commissioning.(Reference : Clause 2.4 of eligibility criteria) along		

	<p>with documentary proof.</p> <p>(p) Certificate for After Sales support certificate. (Reference: Clause 2.4 of eligibility criteria) along with documentary proof in respect of DWLR and telemetry.</p> <p>(q) Details fo DWLR's supplied installed and commissioned alongwith undertaking for no adverse report for atleast 1 year</p> <p>(r) Descriptive Documents, drawings, notes and references of operating and assembly of mechanical parts in respect of DWLR and telemetry alongwith detailed description of the goods' essential technical and performance characteristics.</p> <p>(s) A clause-by-clause commentary on the Purchaser's technical specifications demonstrating substantial responsiveness of the Goods and Services to those specifications or a statement of deviations and exceptions to the provisions of the Technical Specifications. For purposes of the commentary to be furnished above, the Bidder shall note that standards for workmanship, material and goods, and references to brand names or catalogue numbers designated by the Purchaser in its Technical Specifications are intended to be descriptive only and not restrictive. The Bidder may substitute alternative standards, brand names and/or catalogue numbers in its bid, provided that it demonstrates to the Purchaser's satisfaction that the substitutions ensure substantial equivalence to those designated in the Technical Specifications along with the certificates/ documents as specified in the Scope of Work and Technical Specifications Part C, para 1.0 Scope of Work (xix).</p> <p>(t) Non-manufacturer bidders in respect of DWLR and telemetry will submit the manufacturer's authorization Form as per Proforma in Section XIX</p> <p>(u) Tender document duly signed in all pages, scam amd submite online alongwith above.</p> <p>(v) Duly Signed copy of Integrity Pact as per format in Section XIV</p>	
<p>Section II (ITB Clause 2.10</p>	<p>(a) Copy of completion certificate and other documents indicating the contract number, amount of the contract and the date of completion in support of details of work submitted by the bidder, duly certified by the competent authority of the respective organisation be submitted. (Reference : Clause 2.4 of eligibility criteria)</p>	
	<p>(b) Documents establishing receipt of payment in respect of details of works submitted by bidder. Form 26 AS of Income Tax returns, bank statement or any other documentary proof clearly indicating the name of the firm/organisations, payment received be submitted. (Reference : Clause 2.4 of eligibility criteria)</p>	
	<p>(c) Following documents duly certified by the organisation under whom the work has been executed shall be submitted (Reference: Clause 2.4 of eligibilitycriteria) Documents in support of number of wells drilled upto a depth of 200 m.</p>	

NOTE: THE BIDDERS SHALL PUT SERIAL NUMBER ON ALL THE PAGES AS PER CHECKLIST BEFORE UPLOADING ON THE PORTAL. BIDDERS WILL BE RESPONSIBLE IF THEIR BIDS BECOME NON RESPONSIVE DUE TO SUBMISSION WITHOUT PAGE NUMBER AND AS PER CHECKLIST.

MANUFACTURER'S AUTHORIZATION

[The Bidder shall require the Manufacturer to fill in this Form in accordance with the instructions indicated. This letter of authorization should be on the letter head of the Manufacturer and should be signed by a person with the proper authority to sign documents that are legally binding on the Manufacturer. The Bidder shall include it in its bid.]

Date: *[insert date (as day, month and year) of Bid Submission]*
e-Tender Inquiry No. NIET-*[insert number _____]*

To: *[insert complete name of Purchaser]*

WHEREAS

We *[insert complete name of Manufacturer]*, who are official manufacturers of *[DWLR and Telemetry]*, having factories at *[insert full address of Manufacturer's factories]*, do hereby authorize *[insert complete name of Bidder]* to submit a bid the purpose of which is to provide the following Goods, manufactured by us *[insert name and or brief description of the Goods]*, and to subsequently negotiate and sign the Contract against the above e-tender.

We here by extend our full guarantee and warranty in accordance with Clauses of the General Conditions of Contract and Special Conditions of the Contract, with respect to the Goods offered by the above firm against this e-tender.

We as a manufacturer of *[insert type of goods manufactured]* confirm to provide the spare & service support for a minimum period of 10 years after commissioning

Signed:*[insert signature(s)of authorized representative(s) of the Manufacturer]*

Name:*[insert complete name(s)of authorized representative(s)of the Manufacturer]*

Title:*[insert title]*

Duly authorized to sign this Authorization on behalf of:*[insert complete name of Bidder]*

Dated on _____ day of __, _____*[insert date of signing]*

PERFORMA FOR PERFORMANCE STATEMENT

Proforma for Performance Statement (for a period of last seven years)

Bid No..... Date of opening..... Time..... Hours

Name of Firm.....

Order placed by purchaser	Order No. and Date	Description and quantity of ordered equipment	Value of order	Date of completion of delivery		Remarks indicating reasons for late delivery, if any	Has the equipment been satisfactorily functioning? (Attach certificate from purchaser/consignee)
				As per contract	Actual		
1							
2							
3							
4							
.							
.							
.							
.							
.							
.							

Note:

- A) Delivery means the commencement of supply of data on commissioning
- B) *Performance certificate from the client indicating successful receipt of data for the period from..... To..... from..... no of locations, should be submitted for each order failing which the same will not considered.

Signature and seal of the Bidder

BIDDER INFORMATION FORM

Date: *[insertdate(asday,monthandyear) of Bid Submission]*

Page _____ of _____ pages

1. Bidder's Legal Name <i>[insertBidder'slegalname]</i>
2. Bidder's actual or intended Country of Registration: <i>[insertactualorintendedCountryofRegistration]</i>
3. Bidder's Year of Registration: <i>[insertBidder'syearofregistration]</i>
4. Bidder's Legal Address in Country of Registration: <i>[insertBidder'slegaladdressin countryof registration]</i>
5. Bidder's Authorized Representative Information Name: <i>[insertAuthorizedRepresentative'sname]</i> Address: <i>[insertAuthorizedRepresentative'sAddress]</i> Telephone/Faxnumbers: <i>[insertAuthorizedRepresentative'stelephone/faxnumbers]</i> EmailAddress: <i>[insertAuthorizedRepresentative'semailaddress]</i>
6. Attached are copies of original documents of: <i>[check thebox(es)oftheattachedoriginaldocuments]</i> <input type="checkbox"/> Articles of Incorporation or Registration of firm <input type="checkbox"/> In case of government owned entity from the Purchaser's country, documents establishing legal and financial autonomy and compliance with commercial law <input type="checkbox"/> Included are the organizational chart, a list of Board of Directors, and the beneficial ownership

BIDDER'S JV MEMBERS INFORMATION FORM

1. Bidder's Legal Name: <i>[insert Bidder's legal name]</i>
2. Bidder's JV Member's Legal Name: <i>[insert JV's Member legal name]</i>
3. Bidder's JV Member's country of registration: <i>[insert JV's Member country of registration]</i>
4. Bidder's JV Member's year of registration : <i>[insert JV's Member year of registration]</i>
5. Bidder's JV Member's legal address in country of registration: <i>[insert JV's Member legal address in country of registration]</i>
6. Bidder's JV Member's authorized representative information Name : <i>[insert name of JV's Member authorized representative]</i> Address: <i>[insert address of JV's Member authorized representative]</i> Telephone/Fax numbers: <i>[insert telephone/fax numbers of JV's Member authorized representative]</i> Email Address: <i>[insert email address of JV's Member authorized representative]</i>
7. Attached are copies of original documents of <i>[check the box(es) of the attached original documents]</i> <input type="checkbox"/> Articles of Incorporation (or equivalent documents of constitution or association), and/or registration documents of the legal entity named above <input type="checkbox"/> In case of a Government-owned enterprise or institution, documents establishing legal and financial autonomy.
8. Included are the organizational chart, a list of Board of Directors, and the beneficial ownership.

SECTION XX
CONTRACT FORM

SECTION XX

CONTRACT FORM

THIS AGREEMENT made the _____ day of _____ between
_____ (Name, city, Country) (herein after called " The Purchaser" of one part and
_____ (Name, city, Country) (herein after called " The Contractor") of the other part:

WHEREAS the Purchaser is desirous that certain work/ services should be provided by the contractor, viz. (brief description of work and services) and has accepted a bid by the contractor for Construction of PIEZOMETERS 810 Nos in SOFT ROCK/ HARD Rock and Supply, Installation, Commissioning of DWLRs and telemetry, Establishment of Data Acquisition system & its maintenance for Real Time Ground Water Level monitoring and supply of Ground water level, ground water temperature data from site and receipt of data at National Data Centre, CHQ, Faridabad, in a desired format from 810 Nos CONSTRUCTED Piezometers wells Through telemetry systems with 05 years warranty and 02 years AMC in STATES of Uttar Pradesh, Bihar, Jharkhand, West Bengal And Odisha in the sum of (contract price in words and figures)(hereinafter referred to as " the Contract Price").

NOW THIS AGREEMENT WITNESSETH AS FOLLOWS:

- 1) In this agreement words and expression shall have the same meanings as are respectively assigned to them in the conditions of contract referred to.
- 2) The following documents shall be deemed to form and be read and construed as part of this agreement:
 - a) The Technical Bid and the Price Bid submitted by the Bidder,
 - b) The Requirement of work,
 - c) The Technical Specifications,
 - d) The General Conditions of Contract,
 - e) The Special Conditions of Contract, and
 - f) The Purchaser's Notification of Award.
- 3) In consideration of the payments to be made by the Purchaser to the Contractor as hereinafter mentioned, the Contractor hereby covenants with the Purchaser to provide the works and services and to remedy defects therein in conformity in all respects under the provisions of the Contract.
- 4) The Purchaser hereby covenants to pay the Contractor in consideration of the provision of the Goods and services and the remedying of defects therein, the Contract Price or such other sum as may become payable under the provisions of the Contract at the times and in the manner prescribed by the Contract.

IN WITNESS WHEREOF THE parties hereto have caused this Agreement to be executed in accordance with their respective laws and day and year first above written.

Signed, sealed and delivered by the
Said _____ (For the Purchaser)
In the presence of _____

Signed, sealed and delivered by the
Said _____ (For the Supplier)
In the presence of _____