

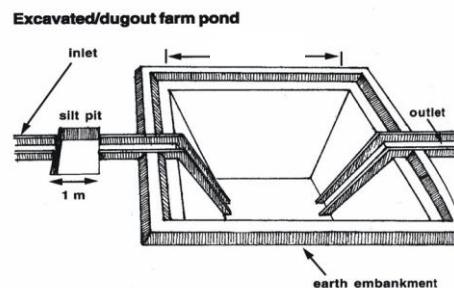

Plan on Artificial Recharge to Groundwater and Water Conservation in Vedasandur Firka, Vedasandur Taluk, Dindigul District, Tamil Nadu

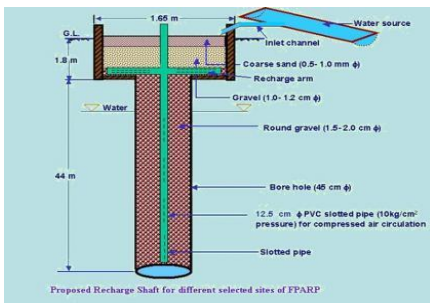

By

Central Ground Water Board
South Eastern Coastal Region
Rajaji Bhawan, Besant Nagar
Chennai
September 2015

Content

S.No.	TOPIC
	At a Glance
1	Introduction
2	Objectives
3.	Study area details
	3.1 Location
	3.2 Geomorphological Setup
	3.3 Landuse and Soil
	3.4 Drainage
	3.5 Rainfall
	3.6 Hydrogeology
	3.7 Dynamic Ground water Resources
4	Spatial data integration/ conservation
5	Planning for recharge
	5.1 Justification of the artificial recharge
	5.2 Availability of surplus surface water for artificial recharge or conservation
	5.3 Proposed interventions including tentative location of artificial recharge structures and water conservation
	5.3.1 Artificial recharge
	5.3.1.1 Check Dam /Nala Bund
	5.3.1.2 Recharge shaft
	5.3.1.3. Revival , repair of water bodies
	5.3.2. Water Conservation Measure
	5.3.2.1 Farm Pond
	5.3.2.2 Micro irrigation system
6.	Tentative Cost Estimation
7.	Implication modalities
	a) Time schedule
	b) Operation and Maintenance

AT GLANCE	
Name of Firka	Vedasandur
Taluk	Vedasandur
District	Dindigul
State	Tamil Nadu
Total area	144.05
Total Suitable area	139.73
Lat. & Lon.	10° 29' 59" to 10° 38' 21" & 77° 52' 40" to 77° 58' 48"
Rainfall	724.7 mm
Monsoon	594.35 mm
Non- Mon soon	130.35 mm
Geology	Crystalline metamorphic gneisses and Charnockites
WATER LEVEL	
Pre - Monsoon	5 to 15 m bgl.
Post - Monsoon	2 to 12 m bgl.
GROUND WATER RESOURCES ESTIMATION	
Replenish able ground water resources	9.6 MCM
Net ground water available	8.64 MCM
Ground water draft for irrigation	15.42 MCM
Groundwater draft for domestic & industrial water supply	0.45 MCM
Total ground water draft	15.86 MCM
Stage of ground water development (%)	184 %
Uncommitted surface runoff available for the Firka	12.84 MCM
Total volume of weathered zone	1728 MCM
Total volume available for recharge (considering 5 m depth from 3 m bgl)	720 MCM
ARTIFICIAL RECHARGE / CONSERVATION MEASURES	
Structures Proposed (tentative)	
Masonry Check dam	1
Nalla Bund	9
Revival, repair of pond, tanks with recharge shaft	11
Improving Water Efficiency / saving	0.7 MCM
Micro irrigation system for 100 ha	
Excepted groundwater recharge	1.21
Total expected groundwater recharge/ saving	1.91
Tentative total cost of the project	Rs.3.79 Cr
Expected rise in water level by recharging/saving	0.89 m

Plan on Artificial Recharge to Groundwater and Water Conservation in Vedasandur Firka, Vedasandur Taluk, Dindigul district, Tamil Nadu

1. Introduction

India is the largest user of groundwater in the world. Food grain security of the country is mainly dependent on water resources and groundwater play major role in irrigation sector. Imprints of Over-Exploitation on groundwater resources are being observed as steep deepening of water levels, drying up of shallow groundwater abstraction structures, ingress of salinity in fresh aquifers etc. which signal towards taking necessity of emergent action for artificial recharge and rainwater harvesting by utilizing surplus runoff and maintaining groundwater resources.

In Tamil Nadu dependency on groundwater has increased many folds during the recent years and the groundwater extraction for irrigation, domestic and industries have resulted in lowering of water levels, long-term water level declining trend and even drying up of wells. In order to regulate the groundwater development, Central Ground Water Board in association with State Ground Water Departments has computed Dynamic Groundwater Resources and categorized firkas as Over Exploited, Critical, Semi Critical and Safe.

Out of 1129 firkas (assessment units) of Tamil Nadu the category of groundwater development is over-exploited in 374 firkas, critical in 48 firkas, semi-critical in 235 firkas, safe in 437 firkas. And the rest 35 firkas are saline. Various measures such as rainwater harvesting, artificial recharge and water use efficiency are successfully practiced by some NGOs, Central and State governments which need replication at larger scale in close coordination with State government agencies and stakeholders, so that capacity building of state implementing agencies and awareness among stakeholders towards artificial recharge and rainwater harvesting can be made.

2. Objectives of the scheme

Objectives of the proposed scheme are

- To upscale recharge activities, supplement additional groundwater resources by harvesting surplus runoff, sustainability of groundwater resources at shallow depths
- Recovery of over-exploited groundwater areas by implementing artificial recharge measures in groundwater stress areas.
- Conservation, development and sustainable management of natural resources including their usage.

3. Study area details

3.1 Location

The total area of Vedasandur firka is 93.69 sq.km and Vedasandur firka lies between North latitudes 10°29'59" to 10°38'21" and east longitudes 77°52'40" to 77°58'48" and falls in Survey of India toposheet number 58F/14 . Location map of Vedasandur firka is given in Figure 1.

Figure - 1

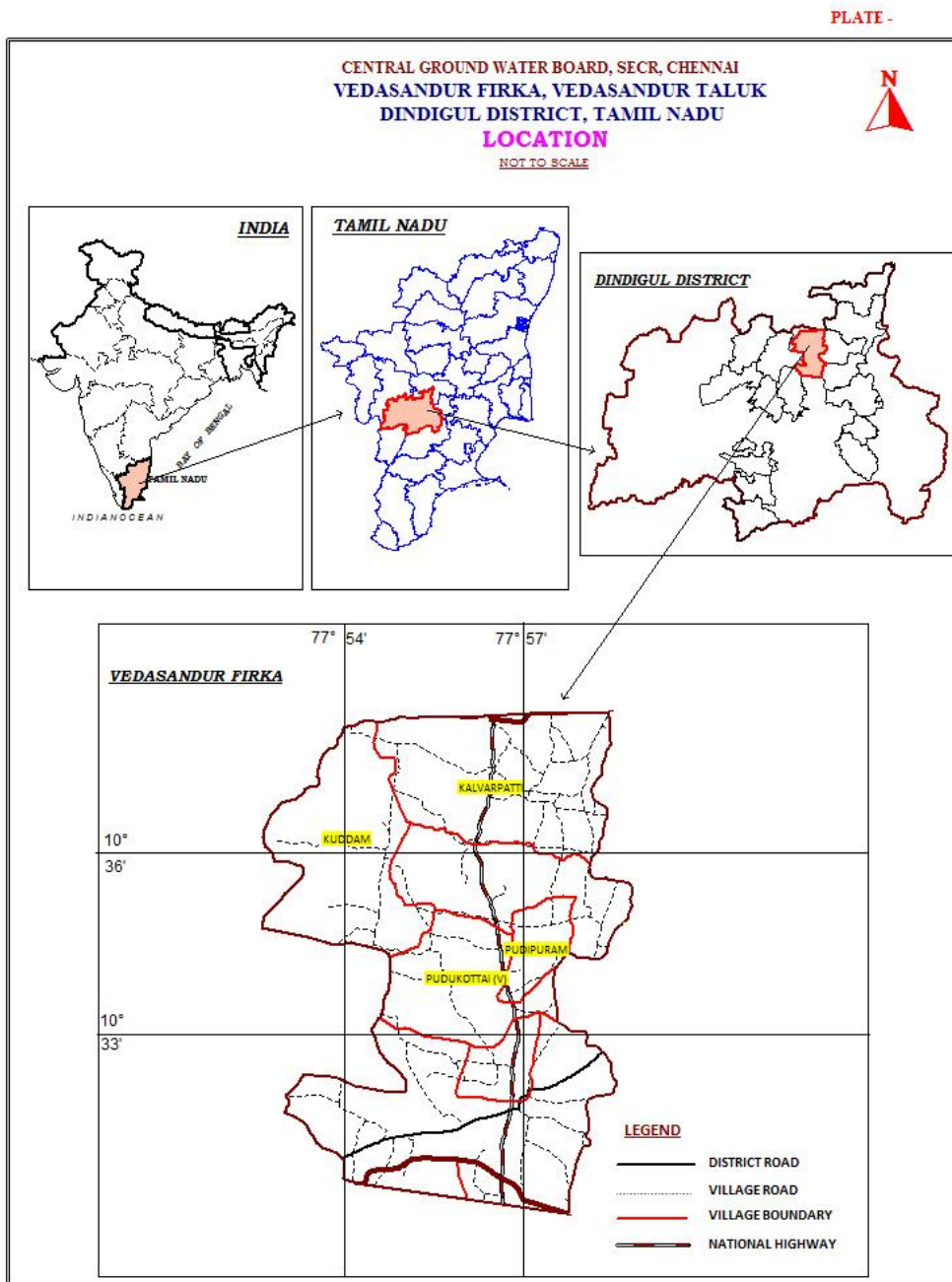

3.2 Geomorphological Set up

Geomorphologically, the area consists of hills (4%) and plain landforms(96%). In plain landforms, Shallow weathered pediplain and dissected/ undissected pediments are occupied almost entire area of the firka. These landforms are influencing the ground water recharge. Hill landforms, namely Structural hills located on western border of the firka as shown in the map occupy 4% area of the firka and these structural hills act as runoff zone. (*Source: IRS, Anna university, Chennai Tamil Nadu*). Geomorphological map prepared using IRS- 1D data on 1: 50,000 scale and units are as per NNRMS standards..The various geomorphological units with its % of coverage area are given in table 1. and shown in figure 2.

Table 1. Various geomorphological units with its % of coverage area in Vedasandur firka

LANDFORMS	% of Area
PEDIPLAIN (WEATHERED) MODERATE	1
STRUCTURAL HILLS	4
DISSECTED/UNDISSECTED	65
PEDIPLAIN (WEATHERED) SHALLOW	30

Figure-2

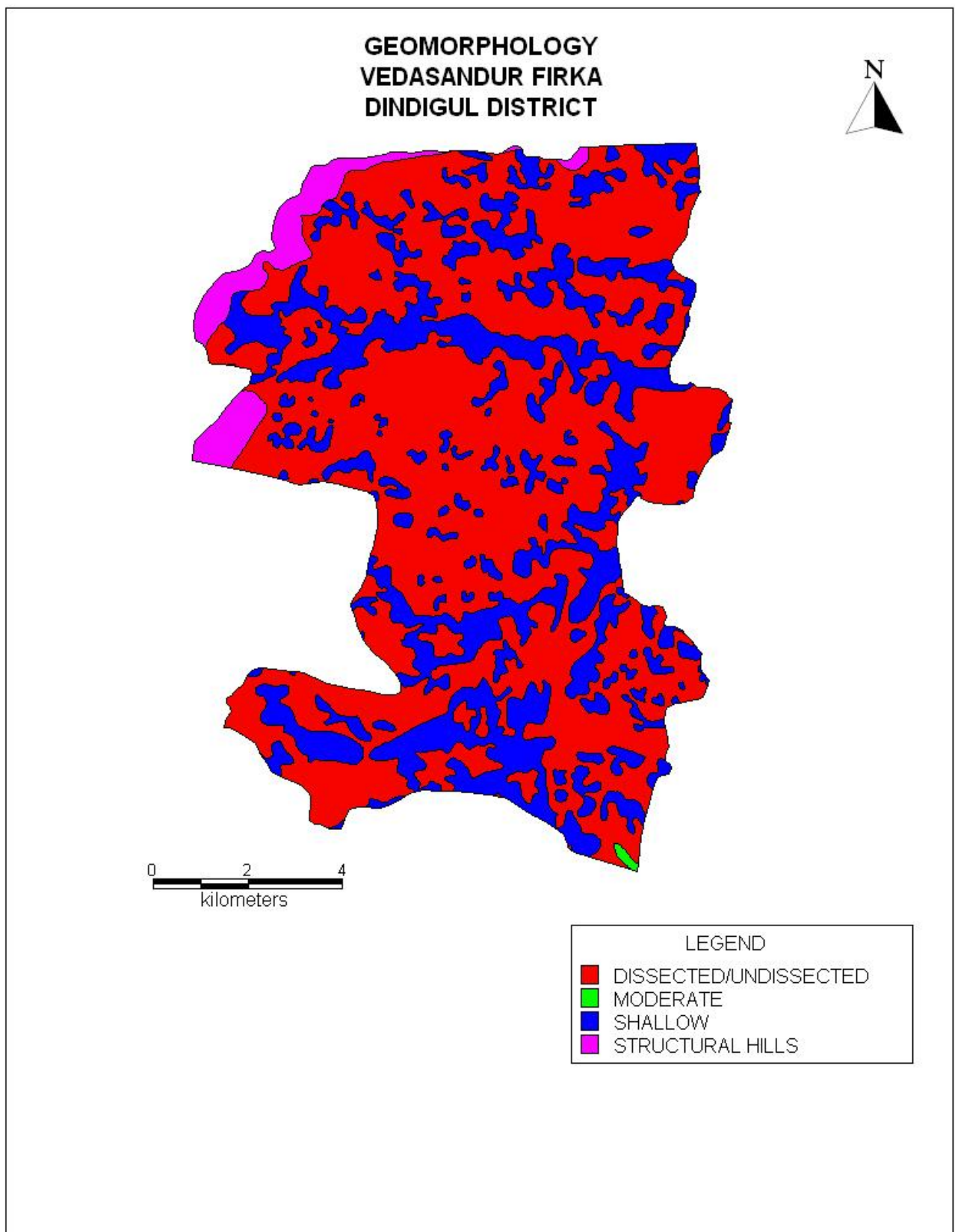

3.3 Land use and soil

The land use pattern of the Vedasandur Firka is given in figure 3. Predominantly the most of the area is characterised by the wet crop, plantation and dry crop (i.,e agricultural field)and accounts for 50 % of the total area of the firka(Source: IRS, Anna university, Chennai Tamil Nadu). This area is highly suitable for water conservation and recharge. The entire Firkas is occupied by rock outcrops with loamy soil.

Figure – 3

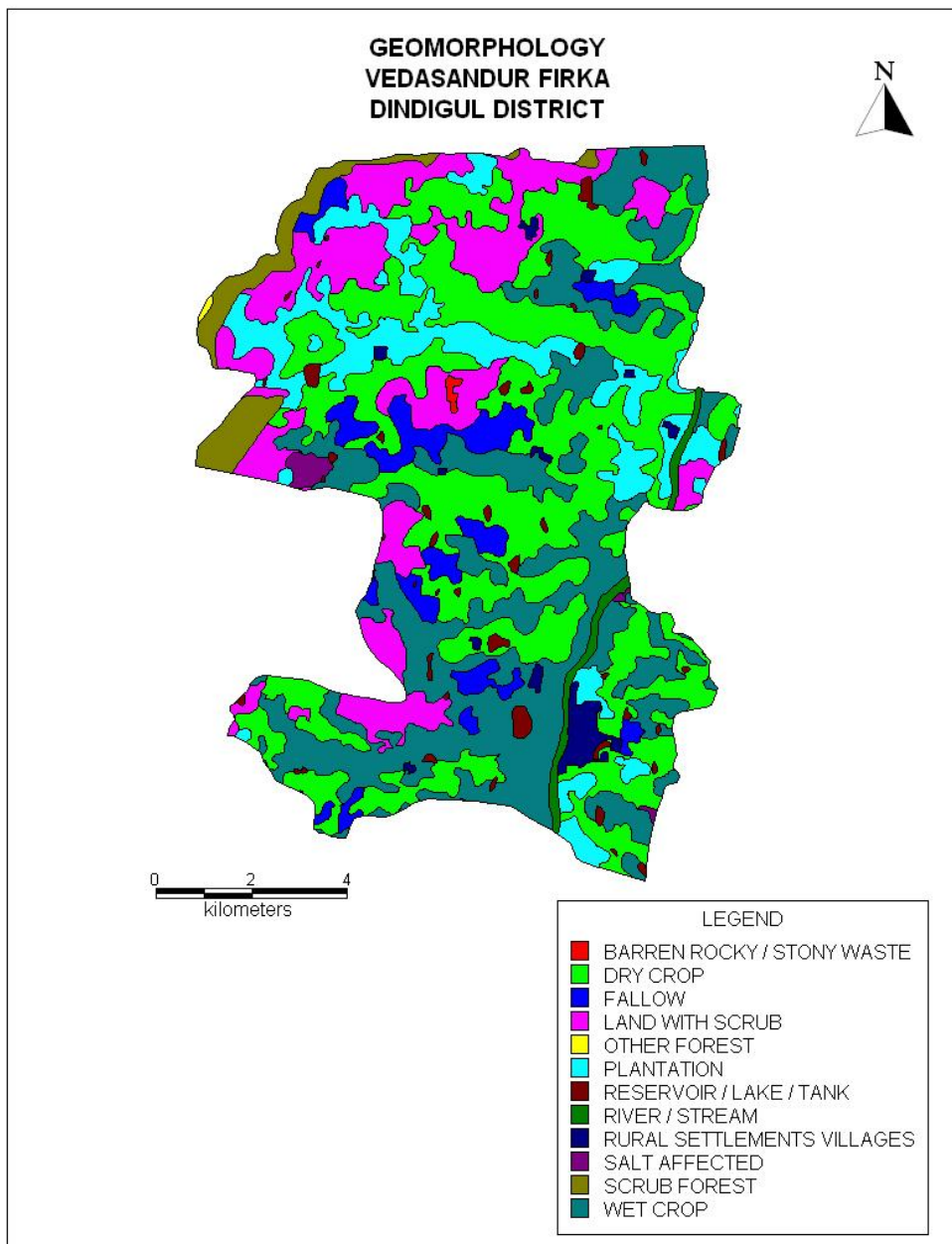

3.4 Drainage

The entire Firka area is within the Kodavanar river sub-basin, which is a tributary of Cauvery river. Basin sub soil water is used to irrigate the lands. Tanks and surface water bodies are spread over the entire firka. The drainage pattern is the dendritic and sub- dendritic. The drainage map of Vedasandur firka is given in Fig 4.

Figure – 4

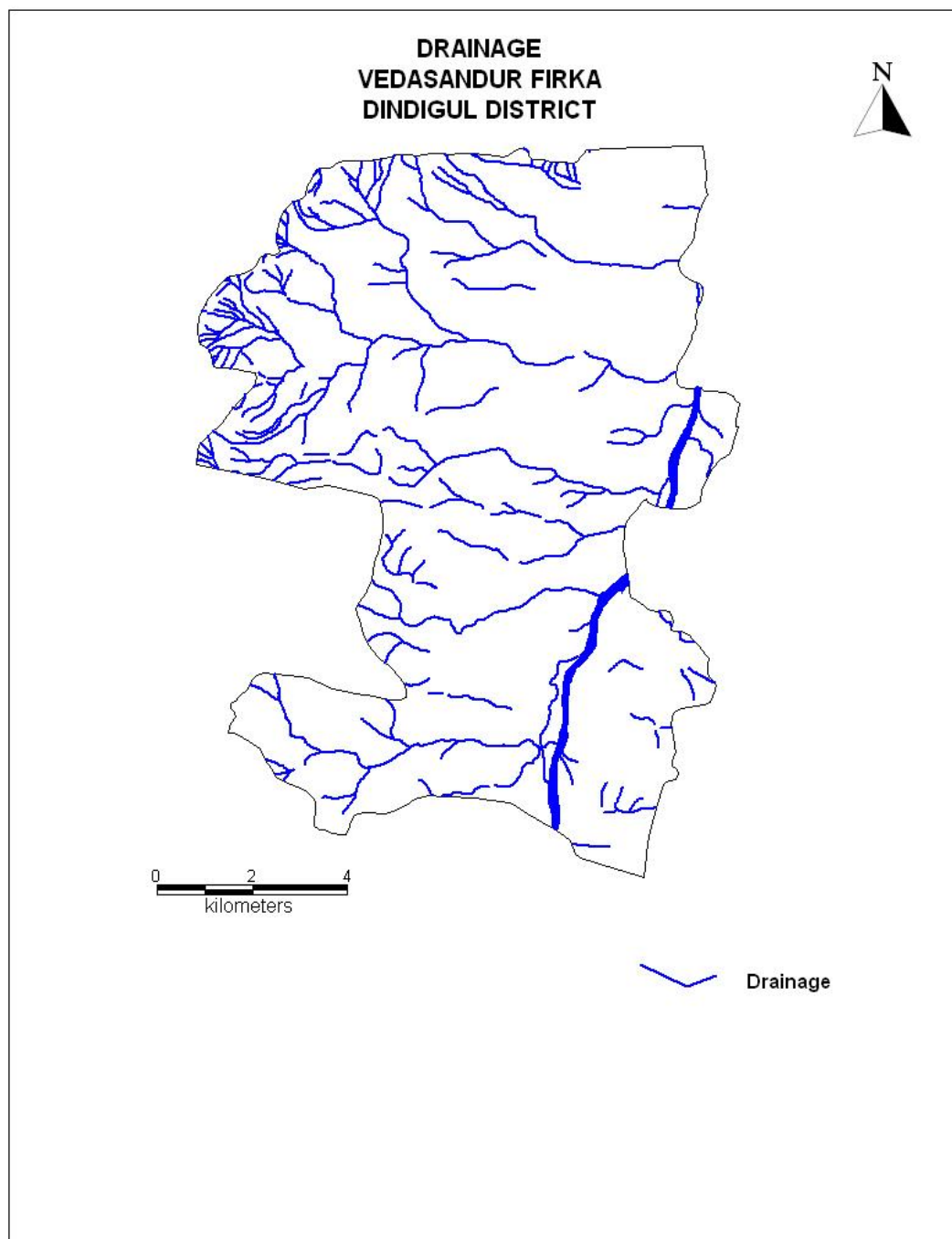

3.5 Rainfall

Vedasandur area falls under tropical climate. The period from April to June is generally hot and dry. The average temperature varies from 26 to 41° C. The humidity is relatively high in the mornings and varies between 65 and 85%. While in the afternoons it varies between 40 and 70%. Vedasandur Firkas receives rainfall from southwest monsoon (June – September), northeast monsoon (October – December) and non-monsoon periods (January – May). The area receives the major rainfall from northeast monsoon and the normal annual rainfall is 724.7mm.

Taluk	Name of Firkas	Area in sq.km	Monsoon rainfall (Jun to Dec) In mm	Non monsoon rainfall (Jan – May) In mm	Total Rainfall In mm
Vedasandur	Vedasandur	144.05	594.35	130.35	724.7

3.6 Hydrogeology

The entire firka is underlain by the crystalline rocks consisting of Charnockites, Hornblede –Biotite gneiss, Epidote-Hornblede gneiss. Ground water occurs in pheratic condition in weathered and fractured gneiss rock formations. The weathering is highly erratic and the depth of abstraction structures is controlled by the degree of weathering and fracturing. Large diameter dug wells are more common ground water abstraction structures in the area. The diameter of the dug well is in the range of 5 to 10 m and depth of dug wells range from 10 to 18 m bgl. The dug wells yield up to 30-100 cu.m in summer months and few wells remains dry. The yield is adequate for irrigation for one or two crops in monsoon period. In summer it is inadequate as the groundwater storage reduces.

Water levels in observation wells tapping shallow aquifers varied from 7.5 to 15 m bgl during pre-monsoon and it varies from 5 to 12 bgl during post monsoon. The hydrogeological map of Vedasandur firka is given in Figure 5. Decadal mean water level of pre-monsoon and post monsoon are given as fig 6a & 6b. The decadal maps reveal that, mean water level during pre-monsoon in majority area is < 6 m bgl likewise during post monsoon majority part is under < 5m ground water level.

Figure – 5

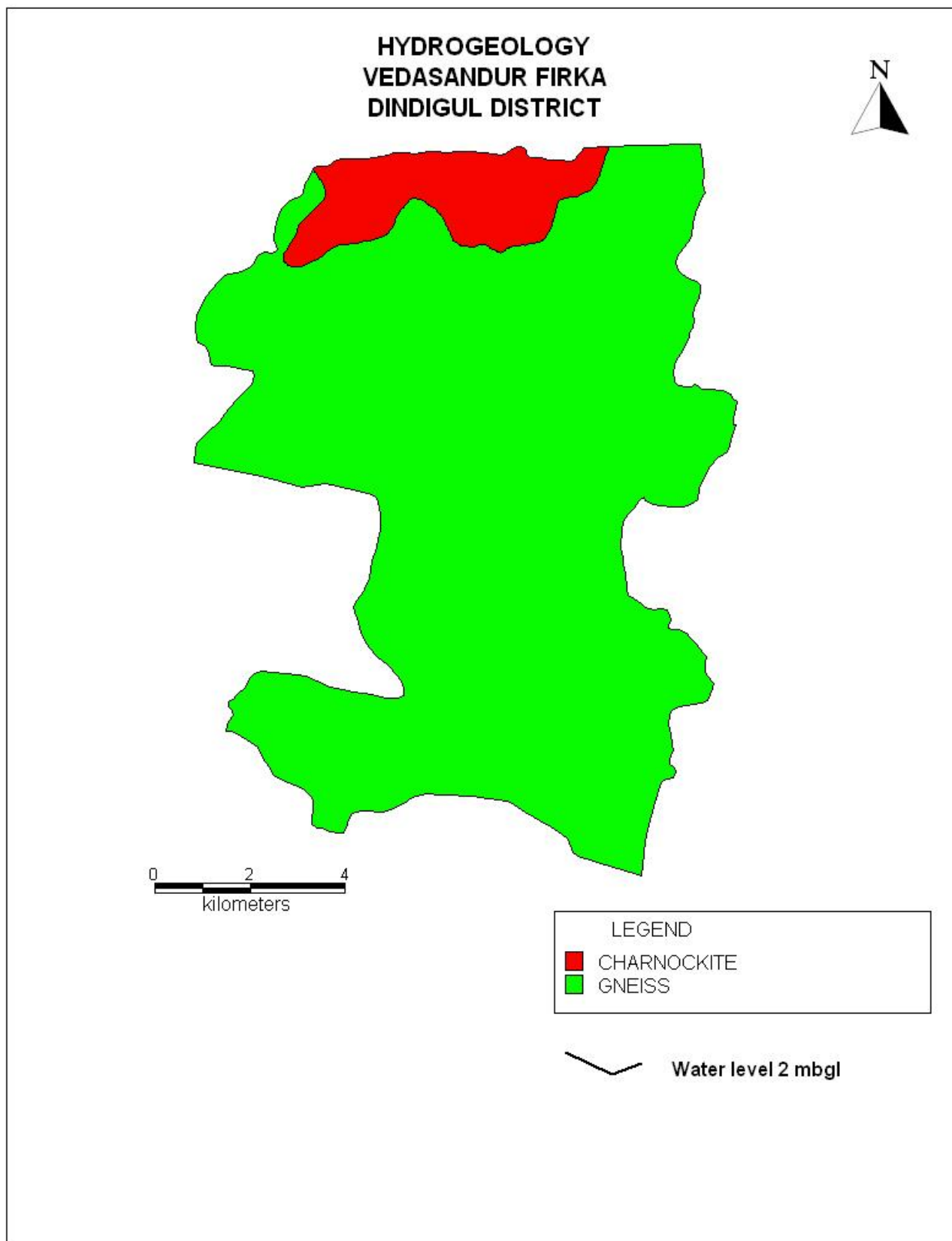

Figure 6A

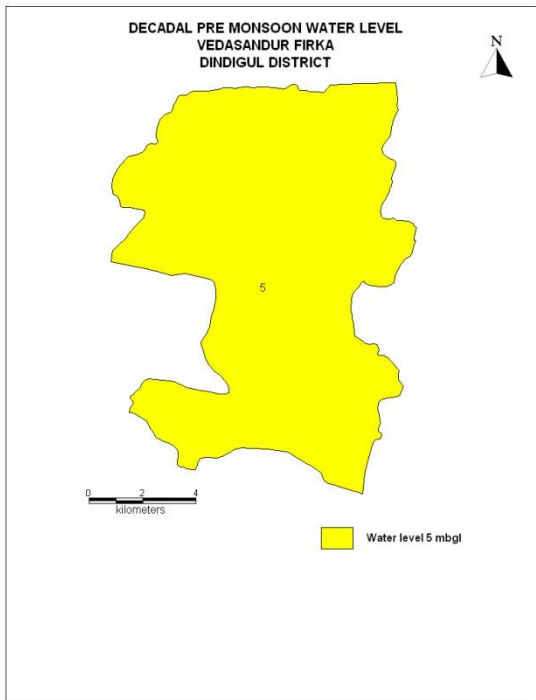
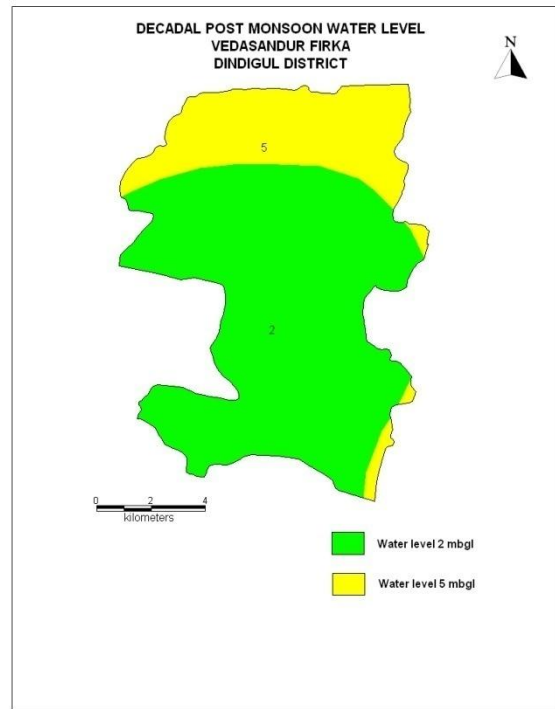

Figure 6B



3.7 Dynamic Ground water Resources

The ground water resources have been computed jointly by Central Ground Water Board and State Ground Water Resources Data Centre (PWD, WRO, Govt. of Tamil Nadu) as on 31st March 2011. The computation has been done using GEC1997 methodology. The salient features of the computations are furnished in table 2.

Table 2. Dynamic Ground water resources estimation of Vedasandur firka

Firka	GW WORTHY AREA	REPLENISH ABLE GROUND WATER RESOURCES	NET GROUND WATER AVAILABLE	GROUND WATER DRAFT FOR IRRIGATION	GROUNDWATER DRAFT FOR DOMESTIC & INDUSTRIAL WATER SUPPLY	TOTAL GROUND WATER DRAFT	STAGE OF GROUND WATER DEVELOPMENT (%)	CATEGORY
	(Sq.Km)	(In MCM)					%	
Vedasan dur	120.58	9.6	8.64	15.42	0.45	15.87	184	OVER EXPLOITED

4. Spatial Data Integration

The potential area for groundwater recharge is highly influenced by Geology, Geomorphology, Land use /land cover, Drainage, Surface Water Body, Weathered Thickness and first fractured Depth in the area. In order to ascertain the suitable area for groundwater recharge in firka, spatial data integration has been attempted using index overlay model in GIS environ. In this model, above seven layers have been integrated by assigning weightage to each layer either 20 or 10 and cumulative weight for all layers as 100. Geomorphology, weathered thickness and surface water bodies are assigned weightage of 20 each and the rest 4 layers viz., geology, land use, drainage and fractured depth have been assigned 10 each out of the total 100 scale, so as the total score would be 100 for all seven layers. Sub-classes of each theme has been assigned scores of 1-10 scale and then all the seven layers have been integrated and a map with feasible recharge zones has been generated. The resultant map has been reclassified into four classes (Very High-low integrated values) indicating the suitable area for artificial recharge and given in fig-7 and described below.

ZONE	% OF AREA COVERAGE	SIGNIFICANCE*
Very high	1	Suitable for all major recharge structures like Percolation pond and stop dam, check dam etc.,
High	15	Suitable for all major recharge structures like stop dam, check dam etc.,
Moderate	81	Suitable for all major recharge structures like earthen check dam, Boulder check dam and Nala bund etc.,
Poor	3	Hilly/Forest /Catchment area

* However, the field verification is required to confirm above potential area for groundwater recharge.

Figure - 7

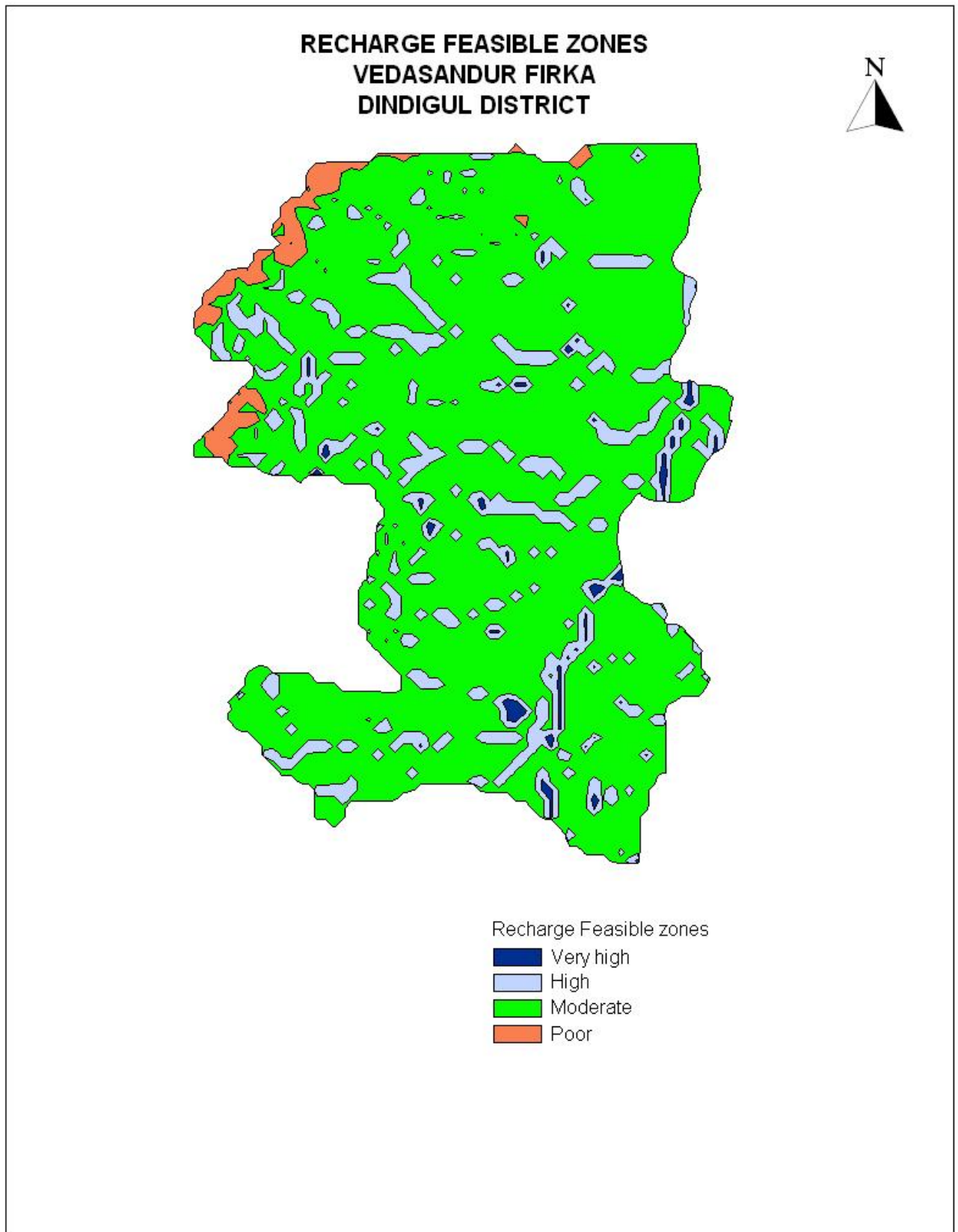

5. Planning for groundwater recharge /conservation

5.1 Justification of the artificial recharge & conservation measures

- ❖ The Vendasandur Firka is with high stage of groundwater development i.e, 184 % and with sufficient amount of uncommitted surface runoff/flow of 12.84 MCM.
- ❖ The total weathered zone available beneath the ground in the firka is 1728 MCM. Out of these total volume available for recharge considering 5 m depth from 3 m) is 720 MCM.
- ❖ The Vendasandur Firka consists of 47 surface water bodies /lakes (cover more than 1 % of the total area of the firka) which are well connected by the drainage. Revival and Recharge of these ponds will enhance the sustainability of the ground water abstraction structures.
- ❖ The water levels in the pre and post season are within range of 2 to 12 m
- ❖ However, most of the ground water developments for agricultural purposes are met through dug-cum bore well and bore wells only. Hence, there is sufficient scope of recharge.
- ❖ Model generated in the Vendasandur areas reveals that more than 80 % of area is moderately suitable for recharge while a limited area of 20 sq.km is highly suitable for artificial recharge.
- ❖ In Vendasandur firka more than 60 % area is characterised by the agricultural activities, there is sufficient scope for the water conservation measures for enhance the crop production and better ground water development.

5.2 Availability of surplus surface water for artificial recharge or conservation

The uncommitted surface flow for Vendasandur Firka is estimated as per the norms followed by State Ground & Surface Water Resources data centre, PWD, Taramani, Chennai (Aug 2015). The available of surplus surface water for Vendasandur Firka is 12.84 MCM.

5.3 Proposed interventions including tentative location of artificial recharge /conservation measures

On basis of above description the following three type of approach have been made to propose artificial recharge or conservation structures.

- a. Artificial recharge
- b. Water conservation measure
- c. Water Efficiency

5.3.1 Artificial recharge

The details of artificial recharge structures proposed along with justification are given below.

5.3.1.1 Check dam/Nala bund

Vedasandur firka area is covered by the seasonal nallahs/drains which carry heavy discharge during monsoon period along with heavy silt load and this is debauched into the water bodies within a short duration. It is proposed that such seasonal nala rivers will be identified and the rain water will be harnessed through construction of series of check dams, nala bund and gabion structures so as to harness this water thereby increasing the resident period of the water in these channels and to increase the soil moisture content. As per the integrated model prediction, it is proposed to construct 1 Check dam and 9 Nala bunds. The tentative location of these 10 ARs are given below and shown in Plate 1. The size and location of these structures are tentative and details field survey is essential to ascertain the exact size and location.

Tentative location of proposed one Check dam in Vedasandur firka

S. NO.	LATITUDE(DD)	LONGITUDE(DD)	TYPE OF ARS
1	10.6248	77.9247	Check Dam

Tentative location of proposed 9 Nalla bund in Vedasandur firka

SL.NO	LATITUDE (DD)	LONGITUDE(DD)	TYPE OF ARS
1	10.6332	77.9303	NALLA BUND
2	10.6297	77.9296	NALLA BUND
3	10.6356	77.941	NALLA BUND
4	10.6295	77.9203	NALLA BUND
5	10.6288	77.912	NALLA BUND
6	10.6315	77.9104	NALLA BUND
7	10.6262	77.908	NALLA BUND
8	10.6045	77.886	NALLA BUND
9	10.5796	77.8895	NALLA BUND

5.3.1.2. Revival, repair of water bodies

The existing ponds and tanks in loose their storage capacity as well as the natural ground water recharge through these water bodies has also become negligible due to siltation and encroachment by farmers for agriculture purposes. There are several such villages where ponds/ tanks are in dilapidated condition. These existing village tanks which are normally silted and damaged can be modified to serve as recharge structure in case these are suitably located to serve as percolation tanks. Through desilting, coupled with providing proper waste weir, the village tanks can be converted into recharge structure. Several such tanks are available in the area which can be modified for enhancing ground water recharge. Studies, however, are needed to ascertain whether the village tanks are suitably located to serve as recharge structures. The locations of about 11 existing ponds/tanks having an area of less than 200 sq.m have been identified with latitude and longitude given below and marked on Plate 1. The above 11 tanks/ponds could be taken up for the renovation with recharge shaft on priority. The design of the recharge shaft is shown as Figure – 8. This shaft structure augment groundwater recharge substantially during flood time. Thus total 16 lakh cu. m of rainwater could be harvested by revival of ponds/tanks alone.

Figure – 8
Recharge Shaft

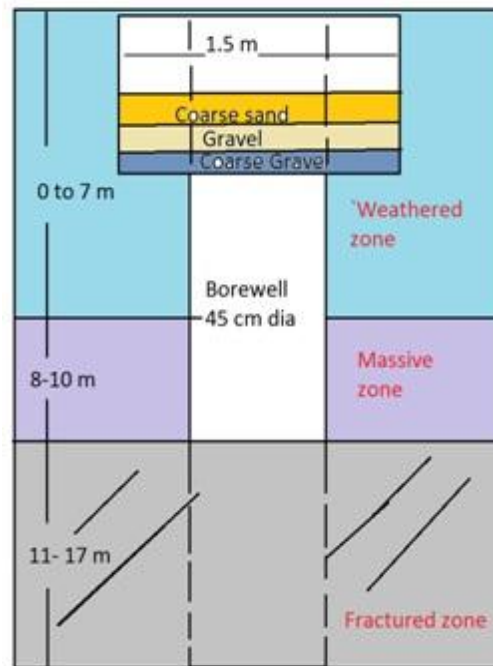

Tentative location of proposed de-siltation of pond/tanks with recharge shaft in Vedasandur firka.

Sl. No.	LATITUDE	LONGITUDE	STRUCTURE	ACTION
1	10.5221	77.9644	TANK/ RESERVOIR	DESILTATION AND RECHARGE
2	10.5951	77.8897	TANK/ RESERVOIR	DESILTATION AND RECHARGE
3	10.5409	77.9698	TANK/ RESERVOIR	DESILTATION AND RECHARGE
4	10.6107	77.8938	TANK/ RESERVOIR	DESILTATION AND RECHARGE
5	10.5296	77.9648	TANK/ RESERVOIR	DESILTATION AND RECHARGE
6	10.5063	77.9565	TANK/ RESERVOIR	DESILTATION AND RECHARGE
7	10.5393	77.9545	TANK/ RESERVOIR	DESILTATION AND RECHARGE
8	10.6094	77.9485	TANK/ RESERVOIR	DESILTATION AND RECHARGE
9	10.6112	77.9415	TANK/ RESERVOIR	DESILTATION AND RECHARGE
10	10.536	77.9243	TANK/ RESERVOIR	DESILTATION AND RECHARGE
11	10.5554	77.9265	TANK/ RESERVOIR	DESILTATION AND RECHARGE

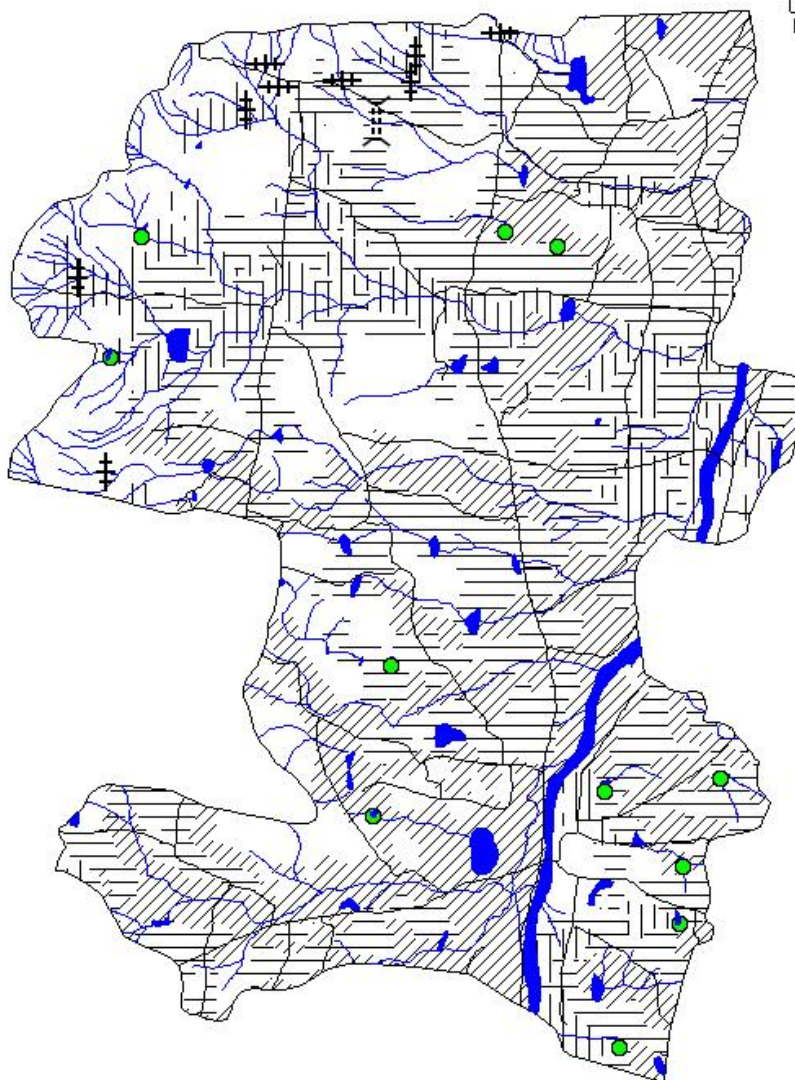

**PROPOSED ARTIFICIAL RECHARGE STRUCTURES
VEDASANDUR FIRKA, DINDIGUL TALUK
DINDIGUL DISTRICT, TAMIL NADU**





LEGEND

-  Drainage
-  Tank/Reservoir
-  Road

PROPOSED TYPE OF ARS

-  Nala Bund (9)
-  Check Dams (1)
-  Desilatanation and Recharge shaft (11)

AREA SUITABLE FOR MICRO IRRIGATION & FARM PONDS

-  Dry crop area
-  Plantation area
-  Wet crop area

5.3.2 Water conservation measure

5.3.2.1 Farm Pond

A farm pond is a large dug out in the earth, usually square or rectangular in shape, which harvests rainwater and stores it for future use. It has an inlet to regulate inflow and an outlet to discharge excess water. The pond is surrounded by a small bund, which prevents erosion on the banks of the pond. The size and depth depend on the amount of land available, the type of soil, the farmer's water requirements, the cost of excavation, and the possible uses of the excavated earth. Water from the farm pond is conveyed to the fields manually, by pumping, or by both methods.

Advantages of Farm Ponds

- They provide water to start growing crops, without waiting for rain to fall.
- They provide irrigation water during dry spells between rainfalls. This increases the yield, the number of crops in one year, and the diversity of crops that can be grown.
- Bunds can be used to raise vegetables and fruit trees, thus supplying the farm household with an additional source of income and of nutritious food.
- Farmers are able to apply adequate farm inputs and perform farming operations at the appropriate time, thus increasing their productivity and their confidence in farming.
- They check soil erosion and minimize siltation of waterways and reservoirs.
- They supplies water for domestic purposes and livestock
- They promote fish rearing.
- They recharge the ground water.
- They improve drainage.
- The excavated earth has a very high value and can be used to enrich soil in the fields, levelling land, and constructing farm roads

As per the Landuse classification of the firka, majority of the area is covered by the agricultural field. Hence it is proposed to construct 100 farm ponds as per the specification of AED, Govt. of Tamil Nadu (30 x 30 x 1.5 m). These 100 farm ponds can hold/ harvest about 135000 cum of rainfall runoff in Single Filling. Considering 4 filling this can accommodate 0.54 MCM of runoff rainfall.

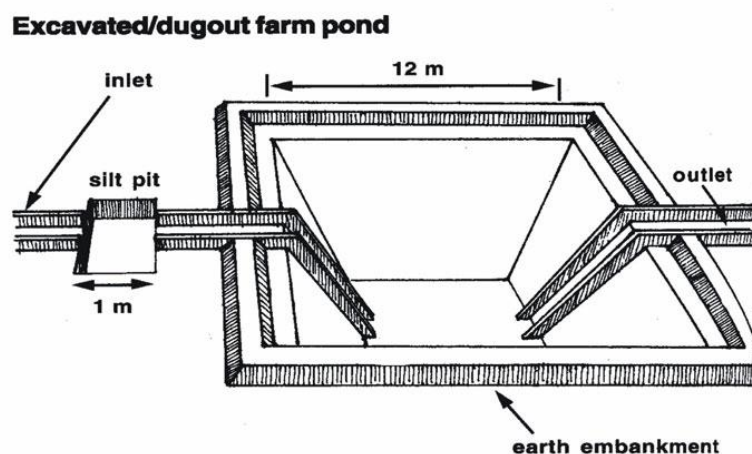

5.3.2.2. Micro Irrigation System (Sprinkler/ drip/ HDPE pipes)

Micro irrigation is defined as the frequent application of small quantities of water directly above and below the soil surface; usually as discrete drops, continuous drops or tiny streams through emitters placed along a water delivery line.

In flood/furrow irrigation method more than 50% of applied water is wasted through seepage to deeper level, localized inundation causes loss through evaporation and it leaches out the nutrients from the plant. While through drip & sprinkler irrigation wastage of irrigational water could be minimized. The studies on different crops, has revealed that irrigation water is saved drastically. The conveyance losses (mainly seepage & evaporation) can be saved up to 25 to 40% through utilization of HDPE pipes. Initially the scheme is proposed to be implemented in worst affected areas showing deepest water levels and significant declining trends. So with micro irrigation system the irrigation draft can be minimised by 50% and an amount of 325000 cum water can be saved for 100 ha of dry crop area.

It is proposed to take up micro irrigation system in 100 ha. The cost estimation for this component has been taken from SOR of Agricultural Engineering Department (AED), Govt. of Tamil Nadu. Tentative locations of proposed micro irrigation are shown in Plate 1.

6. Tentative Cost Estimation

The tentative cost for different activities is given in table below. The unit rates are as followed by the PWD, Govt. of Tamil Nadu (Sources the total estimated cost of the project is Rs 5.35 crores. It is expected that annually about 127 ham (1.27 MCM) of available monsoon runoff can be recharged to ground water. It is also expected to reduce ground water withdrawal by about 30 ham through best irrigational and on-farm practices. A tentative number of feasible structures and cost is given in the table 7.

Table 7. Showing the Cost Estimation of proposed Artificial Recharge Structures

Feasible Artificial Recharge & Water Conservation structures/ activities	Tentative Design	quantity (in nos. or area in sq. m)	Total volume (cu.m)	Tentative unit cost (in Rs lakh)	Total tentative cost (in Rs lakh)	Expected Annual GW recharge (cu.m)
Recharge Structures/ Activities						
Masonry Check dams (4 Fillings)	Crest- 10 -15 m; Height- 0.5 m to 1 m	1	17000	9	9	13600
Nala bunds/ Gabion (4 Fillings)	Width: 5 to 15 m	9	27000	2.0	18	21600
Revival, repair of water bodies (3 fillings)	(~100mx100mx1m)	11	825000	12	132	660000
Recharge shaft with the pond /tanks	(1.5 m dia. with bore well up to 17 m)	11		2.0	22	
Water Conservation Activities						
Farm Pond (in ha) (4 filling)	(30 m x 30m x 1.5 m)	100 unit	600000	1	100	510000
Sprinkler/ drip/ HDPE pipes for 300 ha select area	For 1 ha with 5 m interval HDPE pipe	100 ha	1000000	0.6 /ha	60	700000
Sub total					341	1905200
Impact assessment and O & M						
Piezometers Up to 50 m bgl – 6nos. @ 0.6 lakh					3.6	
Total cost of the project					344.6	
O & M - 5 % of total cost of the scheme					17.23	
Impact assessment to be carried out by the implementing agencies @ 5% of total cost					17.23	
TOTAL					379.06	

Note: The type, number and cost of structure may vary according to site, after the ground truth verification

7. Implication modalities

The implementation of the scheme will be done by the line department of the state selected by the respective State authority. Further, it is to add that more than 50 % MGNREGA works related to water conservation/sustainable management, accordingly a convergence guideline has been made between National Rural Employment Guarantee Act (NREGA) (Ministry of Rural Development) & Programmes of Water Resources (MoWR , RD & GR). The district Dindigul is one among the list of districts identified for Convergence between NREGS and schemes of MoWR. The details of permissible works under convergence are envisaged in the Joint Convergence Guideline.

a.) Time schedule

Steps	1 st Quarter	2 th Quarter	3 rd Quarter	4 th Quarter	5 th Quarter	6 th Quarter	7 th Quarter	8 th Quarter
❖ Identification of line department /implementing agency and preparation of DPR								
❖ Approval of scheme and release of sanction of funds								
❖ Implementation of ARS								

Phase = one quarter or 3 months or equivalent to financial quarter

b.) Operation and maintenance

In all projects Impact assessment has to be carried out to ensure that projects is economically viable, socially equitable and environmentally sustainable by inter-related socio-economic, cultural and human-health impacts, both beneficial and adverse. Accordingly it is proposed a have impact assessment at rate of 5 % of the total cost of the project for 5 years from the completion of artificial recharge.

Prepared under Supervision of

Shri. A. Subburaj, Head of Office, CGWB, SECR, Chennai

Nodal Officer

Dr.S.Subramanian, Senior Hydrogeologist, CGWB, SECR, Chennai

Program – Core Working Committee

Shri. A. Ravi, Sr.Hg (Scientist- D, **CGWB, SECR, Chennai**)

Dr. S. Subramanian, Sr.Hg (Scientist- D, **CGWB, SECR, Chennai**)

Ms. D. Dhayamalar, Sr.Hg (Scientist- D, **CGWB, SECR, Chennai**)

Dr.B. Umapathi, Sr.Hg (Scientist- D, **CGWB, SECR, Chennai**)

Shri. R. Arumugam , Scientist D, **CGWB, SECR, Chennai**

Compiled by

Dr.S.Subramanian, Senior Hydrogeologist, **CGWB, SECR, Chennai**

जीविका, समृद्धि एवं सुशहलीकेलिएजलसंचयनकरें

CONSERVE WATER FOR SUSTENANCE, PROSPERITY AND HAPPINESS

विस्तृतजानकारीकेलिएसंपर्ककरें:-

क्षेत्रीयनिदेशक

केन्द्रीयभूमिजलबोर्ड

दक्षिणपूर्वीतटीयक्षेत्र

ई-1,सी-ब्लॉक,राजाजीभवन

बेसंतनगर

Contact for further details

The Regional Director

Central Ground Water Board

South Eastern Coastal Region

E1, C Block, Rajaji Bhawan

Besant Nagar

Chennai –600090