	Government eProcurement System	eProcurement System Government of India
	Tender Details	Date : 25-Feb-2025 02:00 PM

 Print

Basic Details

Organisation Chain	Central Ground Water Board Superintending Engineer-CHQ-Faridabad-CGWB		
Tender Reference Number	NIET No. 19/2022-23/MMS-I		
Tender ID	2023_CGWB_769358_3	Withdrawal Allowed	Yes
Tender Type	Open Tender	Form of contract	Works
Tender Category	Works	No. of Covers	2
General Technical Evaluation Allowed	No	ItemWise Technical Evaluation Allowed	No
Payment Mode	Offline	Is Multi Currency Allowed For BOQ	No
Is Multi Currency Allowed For Fee	No	Allow Two Stage Bidding	No

Payment Instruments

Offline	S.No	Instrument Type
	1	Bank Guarantee
	2	Demand Draft
	3	FDR

Cover Details, No. Of Covers - 2

Cover No	Cover	Document Type	Description
1	Fee/PreQual/Technical	.pdf	Documents as listed in Checklist of tender document with index and proper page numbering
		.pdf	Additional Documents as listed in Checklist of tender document with index and proper page numbering
		.pdf	Any other document in support of eligibility of bidder as per tender document
		.pdf	Additional Documents if any
		.pdf	Scanned copy of EMD and tender fees
2	Finance	.xls	Duly filled BOQ

Tender Fee Details, [Total Fee in ₹ * - 5,000]

Tender Fee in ₹	5,000	Fee Payable At	Bhujal Bhawan,
Fee Payable To	DDO, CGWB,		

EMD Fee Details

EMD Amount in ₹	10,29,680	EMD Exemption Allowed	No
EMD Fee Type	percentage	EMD Percentage	2.0%

	CHQ, Faridabad	CGWB, CHQ, Faridabad 121001	EMD Payable To	DDO, CGWB, CHQ, Faridabad	EMD Payable At	Bhujal Bhawan, CGWB, CHQ, Faridabad 121001
Tender Fee Exemption Allowed	Yes					

[Click to view modification history](#)

Work /Item(s)					
Title	FOR CONSTRUCTION OF PIEZOMETERS 61 NOS IN HARD ROCK / BOULDRARY IN THE UT OF LADDAKH FOR CONSTRUCTION OF PIEZOMETERS 61 NOS IN HARD ROCK / BOULDRARY IN THE UT OF LADDAKH				
Work Description	FOR CONSTRUCTION OF PIEZOMETERS 61 NOS IN HARD ROCK / BOULDRARY IN THE UT OF LADDAKH				
Pre Qualification Details	As per Tender Document				
Independent External Monitor/Remarks	NA				
Show Tender Value in Public Domain	Yes				
Tender Value in ₹	5,14,84,000	Product Category	Drilling Works	Sub category	NA
Contract Type	Tender	Bid Validity(Days)	120	Period Of Work (Days)	300
Location	Faridabad	Pincode	121001	Pre Bid Meeting Place	CGWB, CHQ, Faridabad
Pre Bid Meeting Address	Bhujal Bhawan, CGWB, CHQ, Faridabad 121001	Pre Bid Meeting Date	05-Mar-2025 03:00 PM	Bid Opening Place	Bhujal Bhawan, CGWB, CHQ, Faridabad 121001
Should Allow NDA Tender	No	Allow Preferential Bidder	No		

Critical Dates			
Publish Date	25-Feb-2025 06:00 PM	Bid Opening Date	20-Mar-2025 01:00 PM
Document Download / Sale Start Date	25-Feb-2025 06:00 PM	Document Download / Sale End Date	19-Mar-2025 12:00 PM
Clarification Start Date	25-Feb-2025 06:00 PM	Clarification End Date	05-Mar-2025 03:00 PM
Bid Submission Start Date	25-Feb-2025 06:00 PM	Bid Submission End Date	19-Mar-2025 12:00 PM

Tender Documents				
NIT Document	S.No	Document Name	Description	Document Size (in KB)
	1	Tendernotice_1.pdf	Tender Document	3510.79
Work Item Documents	S.No	Document Type	Document Name	Description
	1	Tender Documents	TenderDocumentPackage8CLadakh.pdf	Tender Document
	2	BOQ	BOQ_894360.xls	BoQ
				2792.16
				293.00

Bid Openers List			
S.No	Bid Opener Login Id	Bid Opener Name	Certificate Name
1.	dkshaunak-cgwb@gov.in	Dinesh Kumar Shaunuck	DINESH KUMAR SHAUNUCK
2.	tarang-cgwb@gov.in	TARANG BHATT	TARANG BHATT
3.	eediv3-cgwb@nic.in	Keshab Chandra Nayak	SATYENDRA NARAYAN SINGH

Tender Properties

Auto Tendering Process allowed	No	Show Technical bid status	Yes
Show Finance bid status	Yes	Stage to disclose Bid Details in Public Domain	Technical Bid Opening
BoQ Comparative Chart model	Normal	BoQ Comparative chart decimal places	2
BoQ Comparative Chart Rank Type	L	Form Based BoQ	No

TIA Undertaking

S.No	Undertaking to Order	Tender complying with Order	Reason for non compliance of Order
1	PPP-MII Order 2017	Agree	
2	MSEs Order 2012	Agree	

Tender Inviting Authority

Name	Superintending Engineer
Address	Superintending Engineer, Bhujal Bhawan, CGWB, CHQ, Faridabad 121001

Tender Creator Details

Created By	Dinesh Kumar Shaunuck
Designation	AE
Created Date	25-Feb-2025 01:50 PM

**Government of India
Ministry of Jal Shakti,
Department of Water Resources, River Development and
Ganga Rejuvenation
Central Ground Water Board Bhujal Bhawan, NH-IV,
Faridabad, Pin - 121001**

**E-TENDER INQUIRY
FOR CONSTRUCTION OF PIEZOMETERS 61 NOS IN HARD ROCK /
BOULDARY IN THE UT OF LADDAKH**

e-Tender Inquiry Number : **NIET No. 19/2022-23/MMS-I**

TENDER DOCUMENT

INDEX

Section		Contents	Page
Section	A.	Cover Page	1
Section	B.	INDEX	2
Section	I.	Notice Inviting e-Tenders (NIT)	3-5
Section	II.	Instructions to Bidders (ITB)	6-20
Section	III.	General Conditions of Contract (GCC)	21-49
Section	IV.	Special Conditions of Contract (SCC)	50-60
Section	V.	Scope of Work and Technical Specifications	61-79
Section	VI.	Bill of Quantities and Summary of Packages	80-94
Section	VII.	Tentative List of Locations	95-97
Section	VIII.	Formats for Submission of Data	98-110
Section	IX.	Drawings	111-122
Section	X.	Bidding Data	123-126
Section	XI.	Formats for Qualification Information	127-130
Section	XII.	Bank Guarantee Form for EMD	131-132
Section	XIII.	Bank Guarantee Form for Performance Security and Mobilisation Advance	133-136
Section	XIV.	Tender Acceptance Form and Integrity Pact	137-144
Section	XV.	Instructions for Online Submission of Tenders	145-148
Section	XVI.	Safety Code	149-158
Section	XVII.	Model Rules for the Protection of Health and Sanitary Arrangements for Workers	159-165
Section	XVIII.	Contractor's Labour Regulations	166-172
Section	XIX.	Checklist	173-178
Section	XX.	Contract form	179-180

SECTION- I

NOTICE INVITING TENDERS (NIT)

Government of India

Ministry of Water Resources, River Development and Ganga Rejuvenation
Bhujal Bhawan, NH-IV, Central Ground Water Board,
Faridabad, Pin - 121001
Phone:0129247721
Email: seop-cgwb@nic.in

e-Tender Inquiry No. NIET No. 19/2022-23/MMS-I

NOTICE INVITING TENDERS (National Competitive Bidding)

- 1 For and on behalf of President of India, The Chairman, Central Ground Water Board, invites online bid under two-bid system (technical bid and financial bid) at CPP portal <http://eprocure.gov.in/eprocure/app> from eligible and qualified bidders for Construction of PIEZOMETERS (61 Nos) in HARD Rock/Bouldary IN THE UT OF LADDAKH.

2

Tender ID	Name of Package	Region	Estimated Cost in INR excluding GST	EMD in INR
	Package 8-C	Laddakh	5,14,84,000/-	10,29,680/-

Critical Dates		Date	Time
1	Dates of Online Publication of Tender Documents in CPP portal		
2	Dates of Tender Document Download	Start	
3		End	
4	Deadline for seeking further information/ clarifications through email		
5	Date of Pre-Bid Meeting		
6	Dates of Online Submission of Tender	Start	
7		End	
8	Deadline for Physical Submission of Cost of Tender Documents and EMD/ Bid Security		
9	Time and Date for Opening of Technical Bid		
10	Time and Date for Opening of Financial Bid	Will be communicated online after technical evaluation	

- 3 Interested tenderer may obtain further information about these requirements from the above office during working hours or through email and/or from the websites <http://cgwb.gov.in> and <https://eprocure.gov.in/eprocure/app>
- 4 Tender documents may be downloaded from the above websites. The bidders must pay non-refundable fee of Rs.5000/- (Five Thousand) only in the form of Account

Payee Demand Draft from any of the commercial bank in India, in favour of Drawing & Disbursing Officer, Central Ground Water Board, payable at Faridabad on or before the deadline fixed.

- 5 All tenders must be accompanied with EMD/ Bid Security as mentioned in Para 2 in favour of The Drawing & Disbursing Officer, Bhujal Bhawan, NH-IV, Central Ground Water Board, payable at Faridabad, in the manner prescribed in bidding documents, on or before the deadline fixed.
- 6 In the event of any of the above mentioned tender opening date being declared as a holiday/ closed day or the purchase organization, the tenders will be opened on the next working day at the appointed time.
- 7 Bids shall be received online only at the website of CPP portal <https://eprocure.gov.in/eprocure/app>.
- 8 Aspiring bidders who have not enrolled/ registered in CPP portal are advised to enroll/ register before participating through the portal. The portal enrolment is free of cost. The bidders are advised to go through the instructions provided at section-XV: 'Instructions for online bid submission'.
- 9 The bidders will be at liberty to be present either in person or through an authorised representative, who must carry 'Bid Acknowledgement Receipt', at the time of opening of bid or can view the bid opening event online at their remote end.
- 10 **This Tender can be Cancelled/Withdrawn any time without assigning any reasons to bidders/ tenderers.**
- 11 **NO grievances/complaints will be considered/replied during Technical Bid evaluation process. Bidders can send their grievances/complaints after uploading of Technical Bid Evaluation report and before the provided time of opening of Financial Bids (Two working days period will be given in between uploading of Technical Bid Evaluation report and the opening of Financial Bids).**

Superintending Engineer
Bhujal Bhawan, NH-IV,
Central Ground Water Board,
Faridabad, Pin - 121001

SECTION- II

INSTRUCTIONS TO BIDDERS (ITB)

	<u>SECTION- II</u>
	INSTRUCTIONS TO BIDDERS (ITB)
1.	General
	The Employer wishes to receive bids for the Construction of Piezometers in Hard Rock/Bouldary IN THE UT of LADDAKH .Throughout these bidding documents, the terms bid and tender and their derivatives (bidder/tenderer, bid/tendered, bidding/tendering, etc.) are synonymous..
1.1	The Employer has issued these tender enquiry documents for the Construction Of Piezometers in Hard Rock/Bouldary in UT OF LADDAKH and related services as mentioned in Section–V: “Scope of Work and Technical Specifications”, which also indicates, <i>interalia</i> , the Tentative List of Locations.
1.2	This section (Section II: “Instructions to Bidders”) provides the relevant information as well as instructions to assist the prospective tenderers in preparation and submission of tenders. It also includes the mode and procedure to be adopted by the Employer for receipt and opening as well as scrutiny and evaluation of tenders and subsequent placement of contract.
1.3	Before formulating the tender and submitting the same to the Employer, the tenderer should read and examine all the terms, conditions, instructions etc. contained in the tender documents. Failure to provide and/ or comply with the required information, instructions incorporated in these tender documents may result in rejection of its tender.
2	Eligibility Criteria of Bidder
2.1	This invitation to bid is open to any bidder meeting the following requirements : (a) The bidder shall be qualified for the contract as notified by the Employer in subsequent clauses.
2.2	(a) Any tenderer, (proprietorship firms, partnerships firms, companies, corporations, joint ventures) registered with Central or State Government or the Central Ground Water Authority (CGWA) are eligible to participate in the tender. A self attested copy in respect of valid registration/ enlistment with the respective authorities is to be submitted (b) Bidders are permitted to form consortium. The clauses as given below shall be applicable for consortium. i. In case of a consortium /Joint Venture, certified copy of the agreement between various partners shall be submitted with the tender. ii. In case of a consortium /Joint Venture, certified copy of the agreement between various partners shall be submitted with the tender.

- iii. In case of a consortium /Joint Venture, certified copy of the agreement between various partners shall be submitted with the tender.
- iv. The consortium /Joint Venture shall nominate a Representative who shall have the authority to conduct all business for and on behalf of any and all the members of the JV during the bidding process and, in the event the JV is awarded the Contract, during contract execution.
- v. The consortium /Joint Venture will identify a lead partner who will be authorised to execute the contract with the department. All financial transactions and liabilities shall rest with the lead partner.
- vi. JV members are jointly and severally responsible and liable for the contract. For pre- qualification, the JV should fulfil the criteria specified in the pre-qualification document. The attributes to be evaluated will be the same as for individual contractors; however, certain parameters up to the specified limits have to be essentially met by them collectively, some by the lead partner, and some by the other partner, as briefly described below:

X. Qualifying factors to be met collectively:

- (A) Annual turnover;
- (B) Nos. of Well construction experience

Y. Qualifying factors for lead partner:

- (A) *Nos. of Well construction experience*

Not less than of 50 (fifty) percent of the respective limits of above criteria prescribed in case of individual contractors may be accepted;

Z. Qualifying factors for other partner:

Same as for lead partner except that for the factors specified in (Y) above, a lower limit of 25 (twenty-five) per cent.

- vii. A tenderer shall submit only one bid in the same tendering process, either individually as a tenderer or as a partner of a consortium /Joint Venture.
- viii. Number of the members/firms in a joint venture shall not be more than **Three** including the lead partner

(c) A Bidder shall not have a conflict of interest. Any Bidder found to have a conflict of interest shall be disqualified. A Bidder may be considered to have a conflict of interest for the purpose of this bidding process, if the Bidder:

- i. directly or indirectly controls, is controlled by or is under common control with another Bidder or
- ii. receives or has received any direct or indirect subsidy from any other Bidder; or
- iii. has the same legal representative as another Bidder; or
- iv. has a relationship with another Bidder, directly or through common third parties, that puts it in a position to influence the bid of another Bidder, or influence the decisions of the Purchaser regarding this bidding process; or
- v. participates in more than one bid in this bidding process. Participation by a Bidder in more than one Bid will result in the disqualification of all Bids in which such Bidder is involved.

	<p>(d) Bidders will be required to employ at least one ground water professional with minimum qualification of graduate degree in engineering/master's degree in geosciences with minimum 3 years of experience in construction of exploratory & observation, Piezometer wells and similar works. The undertaking for employment of these ground water professional be given.</p> <p>(e) Bidders will be required to deploy at least 2 rigs for the package along with submersible pumps of various capacities, ancillaries equipments tools accessories required for construction of well and pumping test as mentioned in the section V, Scope of Work and Technical specification. An undertaking in this regard should be submitted in the technical Bid.</p> <p>(f) Bid Capacity</p> <p>The bidder should possess the bidding capacity (Equal to or more than total estimated cost specified in the tender document) as calculated by the specified formula. The formula generally used is:</p> <p>Available bid capacity = $A \times 1.5 \times N - B$, where A = Maximum value of engineering (Civil/ Electrical/ Mechanical as relevant to work being procured) works executed in any one year during the last five years (updated at the current price level), taking into account the completed as well as works in progress. N = Number of years prescribed for completion of the work in this tender. B = Value (updated at the current price level) of the existing commitments and ongoing works to be completed in the next 'N' years.</p>
<p>2.3</p>	<p>Average annual financial turnover during the last three years, ending 31st March of the previous financial year should be at least 30% of the estimated cost. (Balance Sheet duly audited and certified by Chartered Accountant)</p> <p>Note: Note: In case of last financial year Bidder may submit the Provisional Balance sheet duly signed by CA.</p>
<p>2.4</p>	<p><i>The bidder should have experience of having successfully completed similar works during last 7 years ending last day of month previous to the one in which tenders are invited:</i></p> <p>(a) <i>Three similar completed works costing not less than the amount equal to 40% of the estimated cost of the Tender</i></p> <p style="text-align: center;"><i>Or</i></p> <p><i>Two similar completed works costing not less than the amount equal to 50% of (estimated cost of the Tender</i></p> <p style="text-align: center;"><i>Or</i></p> <p><i>One similar completed work costing not less than the amount equal to 80% of the (estimated cost of the Tender</i></p> <p style="text-align: center;"><i>Or</i></p> <p><i>Sum total of similar completed works costing not less than the amount equal to 100% of the estimated cost of the Tender in a single financial year.</i></p> <p>(b) Defination of Similar works:</p> <p><i>“Any work in which drilling for exploration/exploitation of natural resources is component of scope of work”</i></p>

	<p>(c) The value of the executed work shall be brought to the current costing level by enhancing the actual value of works at simple rate of 7% per annum calculated from the date of completion to last date of submission of bid.</p> <p>(d) The tenderer shall submit details of works executed by them in last 7 years for qualification of work experiences criteria, documentary proof such as completion certificate & other documents from client clearly indicating the nature/scope of work, contract number, contract amount and actual date of completion, of such works. Rig deployment /copy of work order cannot be considered as work completion. Work completion certificate or part completion certificate is to be submitted.</p> <p>(e) In case the work is done for private/ Government clients, details as per table at Sl.No.3 (a) & 3 (b) of Section XI are to be submitted. Documents are to be submitted. Documents establishing receipt of payment for such works are to be submitted. For this purpose TDS certificate or Form 26 AS of Income Tax department or copy of Bank statement or any other document clearly indicating name of organisation making payment, amount of payment shall be submitted.</p>
2.5	The bidder must submit an undertaking for carrying out chemical analysis of water samples from any NABL accredited lab/labs.
2.6	<p>Well construction Experience</p> <p><i>They must have drilled/completed wells to a depth of at least 100 m. Number of such wells should not be less than 20% of number of wells to be constructed in the Tender during previous 7 (Seven) Financial years for Central Government/ State Government Departments or Public Sector Undertakings or any Project/ any other Public/ Private Customers in India.</i></p>
2.7	<p>After approval of Technical bid, the Financial bid will be opened only after qualifying the Technical Bid. The Financial bid will be evaluated considering the Gross total amount of BOQ including GST. Note: 1. The bidders are requested to quote the rate (excluding GST) against the item in BOQ (Financial bid). The actual Tax (GST) as applicable will be reimbursed only after producing the following proof of tax amount paid to Government (i) A copy of GSTR-1, (ii) A copy of GSTR- 3B, (iii) CA certificate indicating details of invoices against which the payment under GSTR-3B has been made and any other relevant document.</p>
2.8	Deleted

2.9	<p>Tenderers are required to submit duly self attested following documents:-</p> <ul style="list-style-type: none"> (a) Copy of valid registration/ enlistment with the respective authorities (Reference: clause 2.2 of eligibility criteria). (SI.No.1 of Section XI) (b) In case of a consortium, certified copy of the agreement between various partners. (Reference : Clause 2.2 of eligibility criteria) (c) Scanned copy of undertaking of having employed the ground water professional during execution of work. (Reference : Clause 2.2 (d) of eligibility criteria) (d) Scanned copy of Undertaking as per eligibility criteria 2.2 (e). (e) Current Available Bid Capacity of Bidder duly certified by CA (as per clause 2.2 (f)) with documentary proof of “A value i.e. Maximum value of engineering works executed during any last five year” and “B value i.e. value of existing commitments and ongoing works to be completed in the next “N” years.” (f) Details of works completed as per table at Sl. No.3 (a) of Section XI along with documentary proof.(Reference : Clause 2.4 of eligibility criteria) (g) Details of payment received for completed works alongwith documentary proofas per table at Sl. No 3(B) of Section XI (Reference : Clause 2.4 of eligibility criteria) (h) Scanned copy of undertaking as per eligibility criteria 2.5 (i) Details of Borewells/ Tubewells constructed as per table at Sl. No.4 of Section XI.(Reference : Clause 2.6 of eligibility criteria) (j) Scanned copy of EMD: As per clause 13 of Section II Instructions to Bidders. (k) Scanned copy of tender fee (l) Scanned copy of Tender Acceptance letter: As per format in Section XIV (m) Tender document duly signed in all pages, scan and submit online along with above. (n) Duly Signed copy of Integrity Pact as per format in Section XIV
2.10	<p>Bidders have the option to submit the documents listed above in Clause 2.9 online only. In addition only original EMD & Tender Fee to be submitted to Superintending Engineer, Central Ground Water Board, Bhujal Bhawan, NH-IV Faridabad, Haryana 121001on or before deadline of tender submission.</p> <p>Note: Documents listed above at Clause 2.9 are to be mandatorily submitted online along with the bid.</p>
2.11	Deleted
2.12	Non-submission of any document listed in clause 2.9 & 2.10 above, will lead to rejection of the bid of the bidder.
2.13	The eligibility of the bidder shall be decided only as per Section-II Clause 2 Eligibility Criteria of Bidder (Clause 2.1 to 2.12), irrespective of whatsoever elsewhere is mentioned in the tender document.
3	Cost of Bidding Document/ Tendering Expense
3.1	The tenderer shall bear all costs and expenditure incurred and/ or to be incurred by it in connection with its tender including preparation, mailing and submission of its tender and for subsequent processing the same. The Employer will, in no case be responsible or liable for any such cost, expenditure regardless of the conduct or outcome of the tendering process.

4	One Bid per Bidder
4.1	Each bidder shall submit only one bid either by himself or as a partner in a Joint Venture.
5	Site Visit
5.1	The bidder is advised to visit and examine the site of work and its surroundings and obtain for itself on its own responsibility all information that may be necessary for preparing the Bid and entering into a contract for construction of the wells. The costs of visiting the site shall be at the bidder's own expense.
6	Contents of Bidding Documents
6.1	In addition to Section I: "Notice inviting Tender" (NIT) the tender enquiry documents include: Section II: Instructions to Bidders (ITB) Section III: General Conditions of Contract (GCC) Section IV: Special Conditions of Contract (SCC) Section V: Scope of Work and Technical Specifications Section VI: Tentative List of Locations Section VII: Bill of Quantities and Summary of Packages Section VIII: Formats for Submission of Data Section IX: Drawings Section X: Bidding Data Section XI: Formats for Qualification Information Section XII: Bank Guarantee Form for EMD Section XIII: Bank Guarantee Form for Performance Security Section XIV: Tender Acceptance Form and Integrity Pact Section XV: Instructions for Online Submission of Tenders Section XVI: Safety Code Section XVII: Model Rules for the Protection of Health and Sanitary Arrangement for Workers Section XVIII: Contractor's Labour Regulations Section XIX: Checklist. Section XX: Contract form.
7	Pre-Bid Meeting and Clarification of Bidding Documents
7.1	The bidder or his official representative is invited to attend a pre-bid meeting which will take place at Central Ground Water Board, Bhujal Bhawan, NH-IV Faridabad, Haryana 121001 on _____ at _____ hours.
7.2	The purpose of the meeting will be to clarify issues and to answer questions on any matter that may be raised at that stage.
7.3	The bidder is requested to submit any questions in writing/ FAX/e-mail to reach the Employer not later than " <u>Deadline for seeking further information/ clarifications through email</u> ".

7.4	Any modification of the bidding documents listed in Clause 6.1 which may become necessary as a result of the pre-bid meeting shall be made by the Employer exclusively through the issue of an Addendum/ Corrigendum and the same will be available in the web site and not through the minutes of the pre-bid meeting.
7.5	A tenderer requiring any clarification or elucidation on any issue of the tender enquiry documents may take up the same with the Employer in writing or by fax/ e-mail provided that such request is received by the critical date mentioned in Para 2 of Section I (Notice Inviting Tenders). The Employer will publish the response to such queries on CPP portal prior to the prescribed date of submission of tender.
7.6	To assist in the examination, evaluation and comparison of bids, the Employer may at its discretion, ask any bidder for clarification of its bid, including breakdown of unit, rate. The request for clarification and the response shall be in writing, but no change in the price or substance of the bid shall be sought or offered or permitted.
8	Amendments to Bidding Documents
8.1	At any time prior to the deadline for submission of tenders, the Employer may, for any reason deemed fit by it, modify the tender enquiry documents by issuing suitable amendment(s) to it.
8.2	Such an amendment will be notified through website https://eprocure.gov.in/eprocure/app and will be binding on them. The tenderers are advised to visit this website from time to time till the bid submission end date and take note of amendment(s) before uploading their tender.
8.3	In order to provide reasonable time to the prospective tenderers to take necessary action in preparing their tenders as per the amendment, the Employer may, at its discretion extend the deadline for the submission of tenders and other allied time frames, which are linked with that deadline.
9	Language of the Bid
9.1	The tender submitted by the tenderer and all subsequent correspondence and documents relating to the tender exchanged between the tenderer and the Employer, shall be written in the English language.
9.2	The tender submitted by the tenderer and all subsequent correspondence and documents relating to the tender exchanged between the tenderer and the Employer, may also be written in the Hindi language, provided that the same are accompanied by English translation, in which case, for purpose of interpretation of the tender, the English translations shall prevail.
10	Bid Prices

10.1	<p>Unless stated otherwise in the bidding document, the contract shall be for the whole Work based on the unit rates and prices in the Bill of Quantities submitted by the bidder.</p> <p>The bidder shall fill in rates for all items of the Work described in the Bill of Quantities in financial bid. The rate filled in BOQ against the item wise should be exclusive of tax (GST).</p> <p>Note: Bidders are requested not to fill any rates in the technical bid section otherwise the bid will summarily be rejected.</p>
10.2	<p>Prices payable to the Contractor as stated in the contract are firm and not subject to adjustment during the performance of the contract. Prices quoted in rate should be cost per unit against each item in BOQ without GST.</p> <p>The actual Tax GST amount as applicable shall be reimbursed to the contractor only after producing the following proof of tax amount paid to Government (i) A copy of GSTR-1, (ii) A copy of GSTR- 3B, (iii) CA certificate indicating details of invoices against which the payment under GSTR-3B has been made and any other relevant document.</p>
11	Currency of Bid and Payment
11.1	The tenderer shall quote only in Indian Rupees.
12	Bid Validity
12.1	If not mentioned otherwise in the ITB, the tenders shall remain valid for acceptance for a period of 120 days (one hundred and twenty days) after the date of tender opening prescribed in the tender document. In case the last date of submission of bid has been extended, 120 days shall be counted from extended date. Any tender valid for a shorter period shall be treated as unresponsive and rejected.
12.2	If any tenderer withdraws his tender before the said period, then the Employer shall, without prejudice to any other right or remedy, be at liberty to forfeit the said Earnest Money.
12.3	In exceptional cases, the tenderers may be requested by the Employer to extend the validity of their tenders up to a specified period. Such request(s) and responses thereto shall be conveyed by post or by fax/ email followed by post. The tenderers, who agree to extend the tender validity, are to extend the same without any change or modification of their original tender and they are also to extend the validity period of the EMD accordingly. A tenderer, however, may not agree to extend its tender validity without forfeiting its EMD.
12.4	In case the day up to which the tenders are to remain valid falls on/ subsequently declared a holiday or closed day for the Employer, the tender validity shall automatically be extended up to the next working day.
13	Bid Security/ Earnest Money Deposit (EMD)
13.1	Pursuant to ITB clauses 6.1 the tenderer shall furnish along with its tender, earnest money for amount as shown in the NIT. The earnest money is required to protect the Employer against the risk of the tenderers unwarranted conduct as amplified under sub-clause 13.7 below.
13.2	The earnest money shall be denominated in Indian Rupees.

13.3	<p>The earnest money shall be furnished in one of the following forms:</p> <p>(a) Account Payee Demand Draft (b) Fixed Deposit Receipt (c) Bank Guarantee</p> <p>The demand draft, fixed deposit receipt shall be drawn on any commercial bank in India, in favour of the authority specified in the Para 5 of NIT. In case of bank guarantee, the same is to be irrevocable and operative Bank Guarantee (BG) as per the format specified under Section XII in these documents and should be issued by a Scheduled Commercial (i.e. Indian or Foreign Banks included in the Second Schedule of Reserve Bank of India Act, 1934 excluding Co-operative banks or Regional Rural Banks).</p>
13.5	<p>The earnest money shall be valid for a period of 60 (sixty) days beyond the validity period of the tender.</p>
13.6	<p>Unsuccessful tenderers' earnest money will be returned to them without any interest, after expiry of the tender validity period, but not later than 30 days after conclusion of the resultant contract. Successful tenderers earnest money will be returned without any interest, after receipt of performance security from that tenderer.</p>
13.7	<p>Earnest money of a tenderer will be forfeited, if the tenderer withdraws or amends its tender or impairs or derogates from the tender in any respect, withdraws its tender, or fails to sign the contract within the period of validity of its tender. The successful tenderers earnest money will be forfeited if it fails to furnish the required performance security within the specified period.</p>
14	Bid Submission
14.1	<p>Tenders shall be received online only at the website of CPP portal http://eprocure.gov.in/eprocure/app. All the scanned copies of documents comprising the bid shall be serially numbered and mentioned in the checklist provided in section XIX which should be the first document of the bid.</p>
14.2	Deleted
14.3	<p>The tenderer, after submitting its tender, is permitted to alter/ modify its tender within the deadline for submission of tender through online only.</p>
14.4	<p>No tender should be withdrawn after the deadline for submission of tender and before expiry of the tender validity period. If a tenderer withdraws the tender during this period, it will result in forfeiture of the earnest money furnished by the tenderer in its tender.</p>

<p>14.5</p>	<p><u>Documents Comprising the Tender</u></p> <p>The tender to be submitted by tenderer shall contain the following documents, duly filled in, as required:</p> <p>Cover 1 (Technical Bid)</p> <p>(a) Scanned copy of Tender Fee and EMD</p> <p>(b) Documentary evidence, as necessary in terms of clauses 2 and 16.3 establishing that the tenderer is eligible to submit the tender and, also, qualified to perform the contract if its tender is accepted.</p> <p>(c) Tender Acceptance Letter</p> <p>(d) Scanned copy of GST Registration/ TIN/ TAN/ PAN</p> <p>(e) Mandate form as per prescribed format for electronic clearing service.</p> <p>Cover 2</p> <p>(a) Financial Bid.</p> <p>Note: (1) Only rates without GST against each item in BOQ shall be filled up. (2) All BOQs will be evaluated put together as a single package. The bids will be summarily rejected if the bidder does not quote for all the BOQ's of the Package. If the bidder does not quote rate for any item of the BOQ, it will be deemed to be covered under the total cost of the BOQ.</p>
<p>14.6</p>	<p>A tender, which does not fulfil any of the above requirements and/ or gives evasive information/ reply against any such requirement, shall be liable to be ignored and rejected.</p>
<p>14.7</p>	<p>The tender shall either be typed or written in indelible ink and the same shall be signed by the tenderer or by a person(s) who has been duly authorized to bind the tenderer to the contract. The letter of authorization shall be by a written power of attorney, which shall also be furnished along with the tender.</p>
<p>14.8</p>	<p>The tender shall be duly signed at the appropriate places as indicated in the tender documents and all other pages of the tender including printed literature, if any shall be initialled by the same person(s) signing the tender. The tender shall not contain any erasure or overwriting, except as necessary to correct any error made by the tenderer and, if there is any such correction; the same shall be initialled by the person(s) signing the tender.</p>
<p>15</p>	<p>Bid Opening</p>
<p>15.1</p>	<p>The Employer will open the tenders at the specified date and time and at the specified place as indicated in the Para 2 of NIT (Section I).</p> <p>In case the specified date of tender opening falls on/ is subsequently declared a holiday or closed day for the Employer, the tenders will be opened at the appointed time and place on the next working day.</p>

15.2	<p>The bidders will be at liberty to be present either in person or through an authorised representative, who must carry 'Bid Acknowledgement Receipt', at the time of opening of bid or can view the bid opening event online at their remote end.</p> <p>The tender opening official(s) will prepare a list of the representatives attending the tender opening. The list will contain the representatives' names and signatures and corresponding tenderers' names and addresses.</p>
15.3	<p>The technical bids through online in CPPP shall be opened in the first stage, at the prescribed time and date. These bids shall be scrutinized and evaluated by the competent committee/ authority with reference to parameters prescribed in the tender document. Thereafter, in the second stage, the financial bids of only the technically acceptable offers (as decided in the first stage) shall be opened for further scrutiny and evaluation.</p> <p>Note: No bidders shall write the amount in anywhere in technical bid. If so the bid will be treated as non responsive and rejected such bids.</p>
16	<p>Examination of Bids and Determination of Responsiveness</p>
16.1	<p><u>Scrutiny and Evaluation of Tenders</u></p> <p>Tenders will be evaluated on the basis of the terms and conditions already incorporated in the tender enquiry document, based on which tenders have been received and the terms, conditions mentioned by the tenderers in their tenders. No new condition will be brought in while scrutinizing and evaluating the tenders.</p>
16.2	<p><u>Preliminary Scrutiny of Tenders</u></p> <p>The tenders will first be scrutinized to determine whether they are complete and meet the essential and important requirements, conditions as prescribed in the tender enquiry document. The tenders that do not meet the basic requirements are liable to be treated as unresponsive and ignored.</p> <p>The following are some of the important aspects, for which a tender may be declared unresponsive and ignored:</p> <ul style="list-style-type: none"> (a) Tender is unsigned. (b) Tenderer is not eligible. (c) Tender validity is shorter than the required period. (d) Required Tender Fee and EMD have not been provided. (e) Tenderer has not agreed to give the required performance security. (f) Tenderer has not agreed to essential condition(s) specially incorporated in the tender enquiry.

16.3	<p><u>Documents Establishing Tenderer's Eligibility and Qualifications</u></p> <p>The documentary evidence needed to establish the tenderer's qualifications shall fulfil the following requirements:</p> <p>(a) Self attested copy in respect of valid registration/ enlistment with relevant authorities as mentioned in clause 2.2.</p> <p>(b) Audited Balance Sheet of last three financial years</p> <p>(c) Self attested copy of 'Acceptance of Tender'/ 'Notice of Award'/ 'Contract' of similar works, as defined in clause 2.4, during the last seven years (ending on the last day of the month previous to the one in which the tenders are invited) and 'Work Completion Certificate' from the Employer for those works/ documents establishing receipt of payment for such works.</p> <p>(d) List of wells constructed by the contractor where depth of well is 100 m or more with supporting documents in the format prescribed in Section XI(4).</p> <p>(e) All the documents as mentioned in the clause 2.9</p>
16.4	<p><u>Tenderers Capability to Perform the Contract</u></p> <p>The Employer, through the above process of tender scrutiny and tender evaluation will determine to its satisfaction whether the tenderer, whose tender has been determined as the lowest evaluated responsive tender is eligible, qualified and capable in all respects to perform the contract satisfactorily.</p>
16.5	<p>The above mentioned determination will, interalia, take into account the tenderers financial, technical and execution capabilities for satisfying all the requirements of the Employer as incorporated in the tender document. Such determination will be based upon scrutiny and examination of all relevant data and details submitted by the tenderer in its tender as well as such other allied information as deemed appropriate by the Employer.</p>
16.6	<p><u>Contacting the Employer</u></p> <p>From the time of submission of tender to the time of awarding the contract, if a tenderer needs to contact the Employer for any reason relating to this tender enquiry and/ or its tender, it should do so only in writing.</p>
16.7	<p>In case a tenderer attempts to influence the Employer in the Employer's decision on scrutiny, comparison and evaluation of tenders and awarding the contract, the tender of the tenderer shall be liable for rejection in addition to appropriate administrative actions being taken against that tenderer, as deemed fit by the Employer.</p>
17	<p>Award Criteria</p>
17.1	<p>Subject to ITB clause 17.2, the contract will be awarded to the lowest evaluated responsive tenderer decided by the Employer. All BOQs will be evaluated put together as a single package. The bids will be summarily rejected if the bidder does not quote for all the BOQ's of the Package. If the bidder does not quote rate for any item of the BOQ, it will be deemed to be covered under the total cost of the BOQ's.</p>

17.2	<u>Employer's Right to Accept Any Tender and to Reject Any or All Tenders</u> The Employer reserves the right to accept in part or in full any tender or reject any tender without assigning any reason or to cancel the tendering process and reject all tenders at any time prior to award of contract i.e. signing of contract, without incurring any liability, whatsoever to the affected tenderer or tenderers.
17.3	<u>Variation of Quantities at the Time of Award and during the execution of work</u> At the time of awarding of contract and during the execution of work, the Employer reserves the right to increase or decrease, the quantities of works maximum up to 20% without any change in the unit price and other terms and conditions quoted by the tenderer.
18	Notification of Award and Signing of Agreement
18.1	Before expiry of the tender validity period, the Employer will notify the successful tenderer(s) in writing, by registered/ speed post or by email/ fax (to be confirmed by registered/ speed post) that its tender for works, also briefly indicating there in the essential details like description, specification and quantity of the works and related services and corresponding prices are accepted. The successful tenderer must furnish to the Employer the required performance security within 21 days from the date of issue of letter of acceptance. Relevant details about the performance security have been provided under GCC Clause 3 under Section III.
18.2	<u>Issue of Contract</u> Promptly after notification of award, the Employer will mail the contract form (as per Section XX) along with bank guarantee form in duplicate, to the successful tenderer by registered/ speed post.
18.3	Within 21 (twenty-one) days from the date of the contract notification, the successful tenderer will return the original copy of the contract, duly signed and dated, to the Employer by registered/ speed post.
18.4	<u>Non-Receipt of Performance Security and Contract by the Employer</u> Failure of the successful tenderer in providing performance security and/ or returning contract copy duly signed in terms of ITB clause 18.1, 18.2 and 18.3 above shall make the tenderer liable for forfeiture of its EMD and, also, for further actions by the Employer against it.
18.5	Failure of the successful Tenderer to furnish the performance Security shall constitute sufficient grounds for the annulment of the award and forfeiture of the Bid security, in which event the employer may make the award to the next lowest evaluated Tenderer or call for new tenders.
18.6	<u>Return of E M D</u> The earnest money of the successful tenderer and the unsuccessful tenderers shall be returned to them without any interest, whatsoever, in terms of ITB Clause 13.6.

18.7	Publication of Tender Result The result of technical evaluation, financial evaluation and award of contract shall be uploaded on CPP portal.
19	Dispute Resolution Mechanism
19.1	The method of dispute resolution is as indicated in the bidding document.
20	Corrupt and Fraudulent Practices
20.1	It is expected that bidders/suppliers/contractors under this contract observe the highest standard of ethics during the procurement and execution of this contract. In pursuance of this policy, the employer (a) Defines for purpose of these provisions, the terms set forth below as follows: i. 'Corrupt practice' means the offering, giving, receiving or soliciting of any thing of value to influence the action of a public official in the procurement process or in contract execution, and ii. 'Fraudulent practice' means a misrepresentation of facts in order to influence a procurement process or the execution of a contract to the detriment of the employer, and includes collusive practice among Bidders (prior to or after bid submission) designed to establish bid process at artificial non-competition levels and to deprive the employer of the benefits of free and open competition. (b) Will reject a proposal for award of work if he determines that the bidder recommended for award has engaged in corrupt or fraudulent practices in competing for contract in question. Bidders shall be aware of the provision stated in clause 4.3 of the general condition of the contract.
21	This Tender can be Cancelled/Withdrawn any time without assigning any reasons to bidders/ tenderers
22	NO grievances/complaints will be considered/replied during Technical Bid evaluation process. Bidders can send their grievances/complaints after uploading of Technical Bid Evaluation report and before the provided time of opening of Financial Bids (Two working days period will be given in between uploading of Technical Bid Evaluation report and the opening of Financial Bids).

SECTION- III
GENERAL CONDITIONS
OF
CONTRACT
(GCC)

	SECTION- III
	GENERAL CONDITIONS OF CONTRACT
1	Definition and Interpretation
1.1	<p>Definition</p> <p>In this Contract, unless the context requires otherwise, the following terms shall have the meaning ascribed to them hereunder:</p> <p>(i) Works or work means the works by or by virtue of the contract contracted to be executed whether temporary or permanent, and whether original, altered, substituted or additional.</p> <p>(ii) Site means the land/or other places on, into or through which work is to be executed under the contract or any adjacent land, path or street through which work is to be executed under the contract or any adjacent land, path or street which may be allotted or used for the purpose of carrying out the contract.</p> <p>(iii) The Contractor means the individual, firm or company, whether incorporated or not, undertaking the works and includes the legal representative of such individual, or the successors of such firm or company and the permitted assignees of such individual, firm or company.</p> <p>(iv) The expression President, Government or Government of India means the President of India and his successors in office.</p> <p>(v) The contract agreement is being carried out through the Chairman, CGWB on behalf of the President of India,.</p> <p>(vi) The Employer means Superintending Engineer, CGWB acting on behalf of the Chairman, CGWB</p> <p>(vii) The Engineer in charge who is a representative of the Executive Engineer, concerned Division, CGWB shall supervise the work.</p> <p>(viii) Accepting Authority means the authority mentioned in Bidding Data.</p> <p>(ix) Accepted Risks are risks due to riots (other than those on account of contractor's employees), war (whether declared or not) invasion, act of foreign enemies, hostilities, civil war, rebellion, revolution, insurrection, military or usurped power, any acts of Government, damage from aircraft, acts of God such as earthquake, lightening and unprecedented floods, and other causes over which the contractor has no control and accepted as such by the Accepting Authority or causes solely due to use or occupation by Government of the part of the works in respect of which a certificate of completion has been issued or a cause solely due to Employer's faulty design of works.</p> <p>(x) Market Rate shall be the rate as decided by the Employer on the basis of the cost of materials and labour at the site where the work is to be executed plus the percentage mentioned in Bidding Data to cover all overheads and profits.</p> <p>(xi) Schedule(s) referred to in these conditions shall mean the relevant schedule(s) annexed to the bid papers or the standard Schedule of Rates of the Government mentioned in Bidding Data hereunder, with the amendments thereto issued up to the date of receipt of the bid.</p> <p>(xii) Bid Amount means the value of the entire work as stipulated in the letter of award.</p> <p>(xiii) Employer site representative means <i>Hydrogeologist of the Regional office &</i></p>

	<p>Engineer of the Divisional office, nominated by concern Regional Director of CGWB</p> <p>(xiv) GST shall mean Goods and Service Tax - Central, State and Inter State.</p>
1.2	<p>Interpretation</p> <p>(i) The Contract means and includes the documents forming the bids and acceptance thereof and the formal agreement executed between the competent authority on behalf of the President of India and the bidders, together with the documents referred to therein including these conditions, the specifications, designs, drawings and instructions issued from time to time by the Employer and all these documents taken together, shall be deemed to form one contract and shall be complementary to one another.</p> <p>(ii) Where the context so requires, words imparting the singular only also include the plural and vice versa. Any reference to masculine gender shall whenever required include feminine gender and vice versa.</p> <p>(iii) Headings and Marginal notes to these General Conditions of Contract shall not be deemed to form part thereof or be taken into consideration in the interpretation or construction thereof or of the contract.</p> <p>(iv) The original Contract shall remain with the Employer. The contractor shall be furnished, free of cost one certified copy of the contract documents together with all drawings as may be forming part of the bidding documents except standard specifications, Schedule of Rates and similar other printed and published documents. None of these documents shall be used for any purpose other than that of this contract.</p>
1.3	<p>Discrepancies & Adjustment of Errors</p> <p>The several documents forming Contract are to be taken as mutually explanatory of one another, detailed drawings being followed in preference to small scale drawing and figured dimensions in preference to scale and special conditions in preference to General Conditions.</p> <p>In the case of discrepancy between the schedule of Quantities, the Specifications and/or the Drawings, the following order of preference shall be observed:</p> <p>(i) Description of Schedule of Quantities.</p> <p>(ii) Particular Specification and Special Condition, if any.</p> <p>(iii) Drawings.</p> <p>(iv) Technical Specifications.</p> <p>(v) Indian Standard Specifications of B.I.S.</p> <p>If there are varying or conflicting provisions made in any one document forming part of the contract, the Accepting Authority shall be the deciding authority with regard to the intention of the document and his decision shall be final and binding on the Contractor.</p> <p>Any error in description, quantity or rate in Schedule of Quantities or any omission there from shall not vitiate the Contract or release the Contractor from the execution of the whole or any part of the works comprised therein according to drawings and specifications or from any of his obligations under the contract.</p>

1.4	<p>Sufficiency of Tender</p> <p>The Contractor shall be deemed to have satisfied himself before tendering as to the correctness and sufficiency of his tender information for the works and of the rates and prices quoted in the Schedule of Quantities, which rates and prices shall, except as otherwise provided, cover all his obligations under the Contract and all matters and things necessary for the proper completion and maintenance of the works.</p>
1.5	<p>Signing of Contract</p> <p>The successful bidder, on acceptance of his tender by the Accepting Authority, shall, within 15 days from the stipulated date of start of the work, sign and execute the Contract consisting of:</p> <ul style="list-style-type: none"> (i) the invitation for bids, all the documents including drawings, if any, forming the tender as issued at the time of invitation of tender and acceptance thereof together with any correspondence leading thereto, and (ii) Standard Form as mentioned in Bidding Data consisting of: <ul style="list-style-type: none"> a) Various standard clauses with corrections up to the date along with annexure thereto. b) Safety Code. c) Model Rules for the protection of health, sanitary arrangements for workers employed; and d) Contractor's Labour Regulations.
1.6	<p>Works to be carried out</p> <p>The work to be carried out under the Contract shall, except as otherwise provided in these conditions, include all labour, materials, tools, plants, equipment and transport which may be required in preparation of and for and in the full and entire execution and completion of the works. The descriptions given in the Schedule of Quantities shall, unless otherwise stated, be held to include wastage on materials, carriage and cartage, carrying and return of empties, hoisting, setting, fitting and fixing in position and all other labours necessary in and for the full and entire execution and completion of the work as aforesaid in accordance with good industry practice and recognized principles.</p>
2	<p>General Obligations</p>
2.1	<p>Work not to be Sublet and Action in Case of Insolvency or Attempt to influence contract:</p> <p>The contract shall not be assigned or sublet without the prior written approval of the Employer. If the contractor shall assign or sublet his contract, or attempt to do so, or become insolvent or commence any insolvency proceedings or make any composition with his creditors or attempt to do so, or if any bribe, gratuity, gift, loan, perquisite, reward or advantage pecuniary or otherwise, shall either directly or indirectly, before or after the execution of the contract be given, promised or offered by the contractor, or any of his servants or agent or associate to any public officer or person in the employ of Government in any way relating to his office or employment, or if any such officer or person shall</p>

	<p>become in any way directly or indirectly interested in the contract, the Employer shall have power to adopt the course specified in Clause 8.3 hereof in the interest of Government and in the event of such course being adopted, the consequences specified in the said Clause shall ensue.</p>
2.2	<p>Changes in Contractor's organization to be approved:</p> <p>Where the contractor is a partnership firm, the previous approval in writing of the Employer shall be obtained before any change is made in the constitution of the firm. Where the Contractor is an individual or a Hindu undivided family business concern such approval as aforesaid shall likewise be obtained before the Contractor enters into any partnership agreement where-under the partnership firm would have the right to carry out the works undertaken by the Contractor. If previous approval as aforesaid is not obtained, the contract shall be deemed to have been assigned in contravention of Clause 2.1 hereof and the same action may be taken, and the same consequences shall ensue as provided in the said Clause.</p>
2.3	<p>Contractor to Indemnify Government Against Patent Rights:</p> <p>The Contractor shall fully indemnify and keep indemnified the Employer against any action, claim or proceeding relating to infringement or use of any patent or design or any alleged patent or design rights or Intellectual Property Rights and shall pay any royalties which may be payable in respect of any article or part thereof included in the contract. In the event of any claims made under or action brought against the Employer, in respect of any such matters as aforesaid, the contractor shall be notified thereof and the contractor shall be at liberty, at his own expense, to settle any dispute or to conduct any litigation that may arise there from, provided that the contractor shall not be liable to indemnify the Employer if the infringement of the patent or design or any alleged patent or design right is the direct result of an order passed by the Employer in this behalf.</p>
2.4	<p>Withholding and Lien in Respect of Sums Due from Contractor:</p> <p>(i) Whenever any claim or claims for payment of a sum of money arises out of or under the contract against the contractor, the Employer or the Government shall be entitled to withhold and also have a lien to retain such sum or sums in whole or in part from the security, if any deposited by the contractor and for the purpose aforesaid, the Employer or the Government shall be entitled to withhold the security deposit, if any, furnished as the case may be and also have a lien over the same pending finalization or adjudication of any such claim. In the event of the security being insufficient to cover the claimed amount or amounts or if no security has been taken from the contractor, the Employer or the Government shall be entitled to withhold and have a lien to retain to the extent of such claimed amount or amounts referred to above, from any sum or sums found payable or which may at any time thereafter become payable to the contractor under the same contract or any other contract with the Employer or the Government or any contracting person through the Employer pending finalization of adjudication of any such claim.</p> <p>It is an agreed term of the contract that the sum of money or moneys so withheld or</p>

retained under the lien referred to above by the Employer or Government will be kept withheld or retained as such by the Employer or Government till the claim arising out of or under the contract is determined by the arbitrator (if the contract is governed by the arbitration clause) or by the competent court, as the case may be and that the contractor will have no claim for interest or damages whatsoever on any account in respect of such withholding or retention under the lien referred to above and duly notified as such to the contractor. For the purpose of this clause, where the contractor is a partnership firm or a limited company, the Employer or the Government shall be entitled to withhold and also have a lien to retain towards such claimed amount or amounts in whole or in part from any sum found payable to any partner/limited company as the case may be, whether in his individual capacity or otherwise.

- (ii) Government shall have the right to cause an audit and technical examination of the works and the final bills of the contractor including all supporting vouchers, abstract, etc., to be made after payment of the final bill and if as a result of such audit and technical examination any sum is found to have been overpaid in respect of any work done by the contractor under the contract or any work claimed to have been done by him under the contract and found not to have been executed, the contractor shall be liable to refund the amount of over-payment and it shall be lawful for Government to recover the same from him in the manner prescribed in sub-clause (i) of this clause or in any other manner legally permissible; and if it is found that the contractor was paid less than what was due to him under the contract in respect of any work executed by him under it, the amount of such under payment shall be duly paid by Government to the contractor, without any interest thereon whatsoever.

Provided that the Government shall not be entitled to recover any sum overpaid, nor the contractor shall be entitled to payment of any sum paid short where such payment has been agreed upon between Employer on the one hand and the contractor on the other under any term of the contract permitting payment for work after assessment by the Employer.

Any sum of money due and payable to the contractor (including the security deposit returnable to him) under the contract may be withheld or retained by way of lien by the Employer or the Government or any other contracting person or persons through Employer against any claim of the Employer or Government or such other person or persons in respect of payment of a sum of money arising out of or under any other contract made by the contractor with the Employer or the Government or with such other person or persons.

It is an agreed term of the contract that the sum of money so withheld or retained under this clause by the Employer or the Government will be kept withheld or retained as such by the Employer or the Government or till his claim arising out of the same contract or any other contract is either mutually settled or determined by the arbitration clause or by the competent court, as the case may be and that the contractor shall have no claim for interest or damages whatsoever on this account or on any other ground in respect of any sum of money withheld or retained under this clause and duly notified as such to the contractor.

2.5	Levy/ Taxes Payable By The Contractor:
-----	---

	<p>(i) GST, Building and other Construction Workers Welfare Cess or any other tax, levy or Cess in respect of input for or output by this contract shall be payable by the contractor and Government shall not entertain any claim whatsoever in this respect.</p> <p>(ii) The Contractor shall deposit royalty and obtain necessary permit for supply of the materials from local authorities.</p> <p>(iii) If pursuant to or under any law, notification or order any royalty, cess or the like becomes payable by the Employer and does not any time become payable by the contractor to the State Government or Local authorities in respect of any material used by the contractor in the works then in such a case, it shall be lawful to the Employer and it will have the right and be entitled to recover the amount paid in the circumstances as aforesaid from the dues of the contractor.</p>
<p>2.6</p>	<p>Conditions for Reimbursement of Levy/ Taxes, if Levied after Receipt of Tenders</p> <p>All tendered rates shall be inclusive of all taxes (excluding GST) and levies payable under respective statutes.</p> <p>However, pursuant to the Constitution (46th Amendment) Act, 1982, if any further tax or levy is imposed by Statute, after the last stipulated date for the receipt of tender including extensions if any and the contractor thereupon necessarily and properly pays such taxes/ levies, the contractor shall be reimbursed the amount so paid, provided such payment, if any, is not, in the opinion of the Employer (whose decision shall be final and binding on the contractor) attributable to delay in execution of work within the control of the contractor.</p> <p>The contractor shall keep books of accounts and other documents for the purpose of this condition as may be necessary to clearly arrive at such amounts and shall allow inspection of the same by a duly authorized representative of the Employer and further shall furnish such other information/ document as the Employer may require from time to time.</p>
<p>2.7</p>	<p>Relative Working in the Department:</p> <p>The Contractor shall not be permitted to tender for works with the Employer office in which his near relative is posted as Divisional Accountant or as an officer in any capacity as Engineer. He shall also intimate the names of persons who are near relatives to any Gazetted Officer in the department or in the Ministry who are working with him in any capacity or are subsequently employed by him. Any breach of this condition by the Contractor shall render him liable to be removed from the approved list of contractors of the Department. If, however, the contractor is registered in any other department, he shall be debarred from tendering for any breach of this condition.</p> <p>NOTE: By the term “near relatives” is meant wife, husband, parents and grandparents, children and grand children, brothers and sisters, uncles, aunts and cousins and their corresponding in-laws.</p>
<p>2.8</p>	<p>Prohibition to Work as Contractor</p> <p>No engineer of gazetted rank or other gazetted officer employed in engineering or administrative duties in an engineering department of the Government of India shall work as a Contractor or employee of a Contractor for a period of two years after his retirement</p>

	<p>from government service without the previous permission of Government of India in writing. This contract is liable to be cancelled if either the Contractor or any of his employees is found at any time to be such a person who had not obtained the permission of Government of India as aforesaid, before submission of the tender or engagement in the contractor's service, as the case may be.</p>
2.9	<p>Provisions of the Apprentices Act to be Complied with</p> <p>The Contractor shall comply with the provisions of the Apprentices Act, 1961 and the rules and orders issued there under from time to time. If he fails to do so, his failure will be a breach of the contract and the Employer may, in his discretion, cancel the contract. The Contractor shall also be liable for any pecuniary liability arising on account of any violation by him of the provisions of the said Act.</p>
3.0	<p>Security for performance:</p>
3.1	<p>Performance Guarantee:</p> <p>(i) The Contractor shall submit an irrevocable Performance Guarantee of 3% (Three percent) of the tendered amount in addition to other deposits mentioned elsewhere in the contract for his proper performance of the Contract agreement, (not withstanding and/or without prejudice to any other provisions in the contract) within 21 days of issue of letter of Acceptance. This period can be further extended by the Employer up to a maximum period of 7 days on written request of the contractor stating the reason for delays in procuring the Bank Guarantee, to the satisfaction of the Employer. This guarantee shall be in the form of Government Securities or Fixed Deposit Receipts or Guarantee Bonds of any Scheduled Bank or State Bank India in accordance with the form annexed hereto. In case a fixed deposit receipt is furnished by the contractor to the Government as part of the performance guarantee and the Bank is unable to make payment against the said fixed deposit receipt, the loss caused thereby shall fall on the contractor and the contractor shall forthwith on demand furnish additional security to the Government to make good the deficit.</p> <p>(ii) A letter of intent shall be issued in the first instance information the successful tenderer of the decision of the competent authority to accept his tender and the award letter shall be issued only after the Performance Guarantee in any of the prescribed form is received. In case of failure by the contractor to furnish the performance guarantee within the specified period, Government shall without prejudice to any other right or remedy available in law, be at liberty to forfeit the earnest money absolutely.</p> <p>(iii) The Performance Guarantee shall be initially valid up to the stipulated date of completion plus 12months beyond that. In case the time for completion of work gets enlarged, the Contractor shall get the validity of Performance Guarantee extended to cover such enlarged time for completion of work. After recording of the completion certificate for the work by the competent authority, the performance guarantee shall be returned to the contractor, without any interest.</p> <p>(iv) The Employer shall not make a claim under the performance guarantee except for amounts to which the President of India is entitled under the contract (not withstanding and/or without prejudice to any other provisions in the Contract</p>

	<p>agreement) in the event of:</p> <p>a) Failure by the Contractor to extend the validity of the Performance Guarantee as described herein above, in which event the Employer may claim the full amount of the Performance Guarantee.</p> <p>b) Failure by the Contractor to pay President of India any amount due, either as agreed by the contractor or determined under any of the Clauses/ Conditions of the Contract, within 30days of the serving of notice to this effect by Employer.</p> <p>(v) In the event of the Contract being determined or rescinded under provision of any of the Clause/ Condition of the agreement, the performance guarantee shall stand forfeited in full and shall be absolutely at the disposal of the President of India, the employer.</p>
3.2	Retention Money/ Security Deposit:
4	Execution of Work
4.1	<p>Works To Be Executed In Accordance With Specifications, Drawings, Orders Etc.:</p> <p>The Contractor shall execute the whole and every part of work i.e. all items of BOQ in the most substantial and workmanlike manner both as regards materials and otherwise in every respect in strict accordance with the specifications. The Contractor shall also conform exactly, fully and faithfully to the design, drawings and instructions in writing in respect of the work signed by the Employer and the Contractor shall be furnished free of charge one copy of the contract documents together with specifications, designs, drawings and instructions as are not included in the standard specifications specified in Bidding Data or in any Bureau of Indian Standard or any other, published standard or code or, Schedule of Rates or any other printed publication referred to elsewhere in the contract.</p> <p>The contractor shall comply with the provisions of the contract and with the care and diligence execute and maintain the works and provide all labour and materials, tools and plants including for measurements and supervision of all works, structural plans and other things of temporary or permanent nature required for such execution and maintenance in so far as the necessity for providing these, is specified or is reasonably inferred from the contract. The Contractor shall take full responsibility for adequacy, suitability and safety of all the works and methods of construction.</p>
4.2	<p>Deviations/Variations Extent and Pricing:</p> <p>The Employer shall have power (i) to make alteration in, omissions from, additions to, or substitutions for the original specifications, drawings, designs and instructions that may appear to him to be necessary or advisable during the progress of the work, and (ii) to omit a part of the works in case of non-availability of a portion of the site or for any other reasons and the Contractor shall be bound to carry out the works in accordance with any instructions given to him in writing signed by the Employer and such alterations, omissions, additions or substitutions shall form part of the contract as if originally provided therein and any altered, additional or substituted work which the Contractor may be directed to do in the manner specified above as part of the works, shall be carried out by the Contractor on the</p>

same conditions in all respects including price on which he agreed to do the main work except as hereafter provided.

The time for completion of the works shall, in the event of any deviations resulting in additional cost over the tendered value sum being ordered, be extended, if requested by the Contractor, as follows:

- (i) In the proportion which the additional cost of the altered, additional or substituted work, bears to the original tendered value plus
- (ii) 25% of the time calculated in (i) above or such further additional time as may be considered reasonable by the Employer.

In the case of extra item(s) the Contractor may within fifteen days of receipt of order or occurrence of the item(s) claim rates, supported by proper analysis, for the work and the Employer shall within one month of the receipt of the claims supported by analysis, after giving consideration to the analysis of the rates submitted by the Contractor, determine the rates on the basis of the market rates and the Contractor shall be paid in accordance with the rates so determined.

In the case of substituted items, the rate for the agreement item (to be substituted) and substituted item shall also be determined in the manner as mentioned in the aforesaid para.

- (i) If the market rate for the substituted item so determined is more than the market rate of the agreement item (to be substituted) the rate payable to the Contractor for the substituted item shall be the rate for the agreement item (to be substituted) so increased to the extent of the difference between the market rates of substituted item and the agreement item (to be substituted).
- (ii) If the market rate for the substituted item so determined is less than the market rate of the agreement item (to be substituted) the rate payable to the contractor for the substituted item shall be the rate for the agreement item (to be substituted) so decreased to the extent of the difference between the market rates of substituted item and the agreement item (to be substituted).

In the case of contract items, substituted items, contract cum substituted items, which exceed the limits laid down in Bidding Data, the contractor may within 15 days of receipt of order or occurrence of the excess, claim revision of the rates, supported by proper analysis, for the work in excess of the above mentioned limits, provided that if the rates so claimed are in excess of the rates specified in the schedule of quantities the Employer shall within **one** month of receipt of the claims supported by analysis, after giving consideration to the analysis of the rates submitted by the contractor, determine the rates on the basis of the market rates and the contractor shall be paid in accordance with the rates so determined.

The provisions of the preceding paragraph shall also apply to the decrease in the rates of items for the work in excess of the limits laid down in Bidding Data, and the Employer shall after giving notice to the contractor within **one** month of occurrence of the excess and after taking into consideration any reply received from him within 15 days of the receipt of the notice, revise the rates for the work in question within one month of the expiry of the said period of 15 days having regard to the market rates.

	<p>The Contractor shall send to the Employer once every 3 months an up to date account giving complete details of all claims for additional payments to which the Contractor may consider himself entitled and of all additional work ordered by the Employer which he has executed during the preceding quarter failing which the Contractor shall be deemed to have waived his right. However, the Employer may authorize consideration of such claims on merits.</p>
<p>4.3</p>	<p>Action in Case Work not Done as per Specifications:</p> <p>All works under or in course of execution or executed in pursuance of the contract shall at all times be open and accessible to the inspection and supervision of the Employer, his authorized subordinates incharge of the work and all the superior officers, officer of the Quality Control Organization of the Department and of the Chief Technical Examiner's Office, and the Contractor shall, at all times, during the usual working hours and at all other times at which reasonable notice of the visit of such officers has been given to the Contractor, either himself be present to receive orders and instructions or have a responsible agent duly accredited in writing, present for that purpose. Orders given to the Contractor's agent shall be considered to have the same force as if they had been given to the Contractor himself.</p> <p>If it shall appear to the Employer or his authorized subordinates in-charge of the work or to the Engineer in charge of Quality Control or his subordinate officers or to the Chief Technical Examiner or his subordinate officers, that any work has been executed with unsound, imperfect, or unskilful workmanship, or with materials or articles provided by him for the execution of the work which are unsound or of a quality inferior to that contracted or otherwise not in accordance with the contract the Contractor shall, on demand in writing which shall be made within 6 months of the completion of the work from the Employer specifying the work, materials or articles complained of notwithstanding that the same may have been passed, certified and paid for forthwith rectify, or remove and reconstruct the work so specified in whole or in part, as the case may require or as the case may be, remove the materials or articles so specified and provide other proper and suitable materials or articles at his own charge and cost. In the event of the failing to do so within a period specified by the Employer in his demand aforesaid, then the Contractor shall be liable to pay compensation at the same rate as under clause 8.2 of the contract (for non-completion of the work in time) for this default.</p> <p>In such case the Employer may not accept the item of work at the rates applicable under the contract but may accept such items at reduced rates as the competent authority may consider reasonable during the preparation of on account bills or final bill if the item is so acceptable without detriment to the safety and utility of the item and the structure or he may reject the work outright without any payment and/or get it and other connected and incidental items rectified, or removed and re-executed at the risk and cost of the Contractor. Decision of the Employer to be conveyed in writing in respect of the same will be final and binding on the Contractor.</p>
<p>4.4</p>	<p>Contractor Liable For Damages, Defects During Defects liability period:</p> <p>The work or any part is being executed, or if any damage shall happen to the work while in</p>

	<p>progress, from any cause whatever or if any defect, shrinkage or other faults appear in the work within the period as specified in the Bidding Document after a certificate final or otherwise of its completion shall have been given by the Employer as aforesaid arising out of defect or improper materials or workmanship the Contractor shall upon receipt of a notice in writing on that behalf make the same good at his own expense or in default the Employer cause the same to be made good by other workmen and deduct the expense from any sums that may be due or at any time thereafter may become due to the Contractor, or from his security deposit or the proceeds of sale thereof or of a sufficient portion thereof. The security deposit of the Contractor shall not be refunded before the expiry defects liability period after the issue of the certificate final or otherwise, of completion of work, or till the final bill has been prepared and passed whichever is later.</p>
<p>4.5</p>	<p>Contractor Shall Supply Tools & Plants, etc. :</p> <p>The Contractor shall provide at his own cost all materials , plant, tools, appliances , implements, ladders, cordage, tackle, scaffolding and temporary works required for the proper execution of the work, whether original, altered or substituted and whether included in the specifications or other documents forming part of the contract or referred to in these conditions or not, or which may be necessary for the purpose of satisfying or complying with the requirements of the Employer as to any matter as to which under these conditions he is entitled to be satisfied, or which he is entitled to require together with carriage thereof to and from the work. The Contractor shall also supply without charge the requisite number of persons with the means and materials, necessary for the purpose offsetting out works, and counting, weighing and assisting the measurement for examination at any time and from time to time of the work or materials. Failing his so doing, the same may be provided by the Employer at the expense of the Contractor and the expenses may be deducted, from any money due to the Contractor, under this contract or otherwise and/or from his security deposit or the proceeds of sale thereof, or of a sufficient portions thereof.</p>
<p>4.6</p>	<p>Employment of Technical Staff and Employees:</p> <p>Contractors Superintendence, Supervision, Technical Staff & Employees</p> <p>(i) The contractor shall provide all necessary superintendence during execution of the work and all along thereafter as may be necessary for proper fulfilling of the obligations under the contract. The contractor shall immediately after receiving letter of acceptance of the Bid and before commencement of the work, intimate in writing to the Employer the name(s), qualifications, experience, age, address(s) and other particulars along with certificates of the principal technical representative to be in charge of the work and other technical representative(s) who will be supervising the work. Minimum requirement of such technical representative(s) and their qualifications and experience shall not be lower than specified in Bidding Document. The Employer shall within 3 days of receipt of such communication intimate in writing his approval or otherwise of such representative(s) to the contractor. Any such approval may at any time be withdrawn and in case of such withdrawal, the contractor shall appoint another such representative(s) according to the provisions of this clause. Decision of the bid accepting authority shall be final and binding on the contractor in this respect. Such a principal technical representative and other technical representative(s) shall be appointed by the contractor soon after receipt of the approval from Employer and shall</p>

be available at site before start of work. All the provisions applicable to the principal technical representative under the clause will also be applicable to other technical representative(s). The principal technical representative and other technical representative(s) shall be present at the site of work for supervision at all times when any construction activity is in progress and also present himself/themselves, as required, to the Employer and/or his designated representative to take instructions. Instructions given to the technical representative(s) shall be deemed to have the same post as if these have been given to the contractor. The principal technical representative(s) shall be actually available at site fully during all stages of execution of work, during recording/checking/test checking of measurement of works and whenever so required by the Employer and shall also note down instructions conveyed by the Employer or his designated representative(s) in the Site Order Book and shall affix his/their signature(s) in token of noting down the instructions and in token of acceptance of measurements/ checked measurements/ test checked measurements. The representative(s) shall not look after any other work. Substitutes, duly approved by Employer of the work in similar manner as aforesaid shall be provided in event of absence of any of the representative(s) by more than two days. If the Employer, whose decision in this respect is final and binding on the contractor, is convinced that no such technical representative(s) is/are effectively appointed or/is/are effectively attending or fulfilling the provision of this clause, a recovery (non-refundable) shall be effected from the contractor as specified in Bidding Data and the decision of the Employer as recorded in the Site Order Book and measurements recorded, checked/test checked in Measurement Books shall be final and binding on the contractor. Further if the contractor fails to appoint a suitable principal technical representative and/or other technical representative(s) and if such appointed persons are not effectively present or are absent by more than two days without duly approved substitute or do not discharge their responsibilities satisfactorily, the Employer shall have full powers to suspend the execution of the work until such date as a suitable other technical representative(s) is/are appointed and the contractor shall be held responsible for the delay so caused to the work. The contractor shall submit a certificate of employment of the technical representative(s) along with every on account bill/final bill and shall produce evidence if at any time so required by the Employer.

- (ii) The contractor shall provide and employ on the site only such technical assistants as are skilled and experienced in their respective fields and such foremen and supervisory staff as are competent to give proper supervision to the work. The contractor shall provide and employ skilled, semiskilled and unskilled labour as is necessary for proper and timely execution of the work. The minimum strength of trained and certified workers shall be 5 % of the total strength employed. The accepted certification shall be granted by government authorize organizations.
- (iii) The Employer shall be at liberty to object to and require the Contractor to remove from the works any person who in his opinion misconducts himself, or is incompetent or negligent in the performance of his duties or whose employment is otherwise considered by the Employer to be undesirable. Such person shall not be employed again at works site without the written permission of the Employer and the persons so removed shall be replaced as soon as possible by competent substitutes.

5.0	Materials and Machineries
5.1	<p>Materials to be Provided by the Contractor :</p> <p>(i) The Contractor shall, at his own expense, provide all materials, required for the works other than those which are stipulated to be supplied by the Employer.</p> <p>The Contractor shall, at his own expense and without delay, supply to the Employer samples of materials to be used on the work and shall get these approved in advance. All such materials to be provided by the Contractor shall be in conformity with the specifications laid down or referred to in the contract. The Contractor shall, if requested by the Employer furnish proof, to the satisfaction of the Employer that the materials so comply. The Employer shall within 10 days of supply of samples or within such further period as he may require intimate to the Contractor in writing whether samples are approved by him or not. If samples are not approved, the Contractor shall forthwith arrange to supply to the Employer for his approval fresh samples complying with the specifications laid down in the contract. When materials are required to be tested in accordance with specifications, approval of the Employer shall be issued after the test results are received.</p> <p>The Contractor shall at his risk and cost submit the samples of materials to be tested or analysed and shall not make use of or incorporate in the work any materials represented by the samples until the required tests or analysis have been made and materials finally accepted by the Employer. The Contractor shall not be eligible for any claim or compensation either arising out of any delay in the work or due to any corrective measures required to be taken on account of and as a result of testing of materials.</p> <p>The contractor shall, at his risk and cost, make all arrangements and shall provide all facilities as the Employer may require for collecting, and preparing the required number of samples for such tests at such time and to such place or places as may be directed by the Employer and bear all charges and cost of testing unless specifically provided for otherwise elsewhere in the contract or specifications. The Employer or his authorized representative shall at all times have access to the works and to all workshops and places where work is being prepared or from where materials, manufactured articles or machinery are being obtained for the works and the Contractor shall afford every facility and every assistance in obtaining the right to such access.</p> <p>The Employer shall have full powers to require the removal from the premises of all materials which in his opinion are not in accordance with the specifications and in case of default, the Employer shall be at liberty to employ at the expense of the Contractor, other persons to remove the same without being answerable or accountable for any loss or damage that may happen or arise to such materials. The Employer shall also have full powers to require other proper materials to be substituted thereof and in case of default, the Employer because the same to be supplied and all costs which may attend such removal and substitution shall be borne by the Contractor.</p> <p>(ii) Mobilization advance</p> <p>Mobilization advance not exceeding 10% of the tendered value may be given, if requested by the contractor in writing within one month of the order to commence the work. Such advance shall be in two or more installments to be determined by the Engineer-in- Charge at his sole discretion. The first installment of such advance shall be released by the Engineer-in-charge to the contractor on a request made by the contractor to the Engineer-</p>

	<p>in-Charge in this behalf. The second and subsequent installments shall be released by the Engineer-in- Charge only after the contractor furnishes a proof of the satisfactory utilization of the earlier installment to the entire satisfaction of the Engineer-in-Charge. Before any installment of advance is released, the contractor shall execute a Bank Guarantee Bonds not more than 6 in number from Scheduled Bank for the amount equal to 110% of the amount of advance and valid for the period till recovery of advance. This (Bank Guarantee from Scheduled Bank for the amount equal to 110% of the balance amount of advance) shall be kept renewed from time to time to cover the balance amount and likely period of complete recovery.</p> <p>(iii) Interest & Recovery</p> <p>The mobilization advance in (ii) above bear simple interest at the rate of 10 percent per annum and shall be calculated from the date of payment to the date of recovery, both days inclusive, on the outstanding amount of advance. Recovery of such sums advanced shall be made by the deduction from the contractors bills commencing after first ten percent of the gross value of the work is executed and paid, on pro-rata percentage basis to the gross value of the work billed beyond 10% in such a way that the entire advance is recovered by the time eighty percent of the gross value of the contract is executed and paid, together with interest due on the entire outstanding amount up to the date of recovery of the installment.</p> <p>If the circumstances are considered reasonable by the Engineer-in-Charge, the period mentioned in (ii) and (iii) for request by the contractor in writing for grant of mobilization advance may be extended at the discretion of the Engineer-in-Charge.</p>
5.2	<p>Dismantled Material Government Property:</p> <p>The Contractor shall treat all materials obtained during dismantling of a structure, excavation of the site for a work, etc. as Government's property and such materials shall be disposed off to the best advantage of Government according to the instructions in writing issued by the Employer.</p>
5.3	<p>Arrangement for Water for Construction:</p> <p>The contractor(s) shall make his/ their own arrangements for water required for the workand nothing extra will be paid for the same. This will be subject to the following conditions.</p> <ul style="list-style-type: none"> (i) That the water used by the contractor(s) shall be fit for construction purposes to the satisfaction of the Engineer-in-Charge. (ii) The Engineer-in-Charge shall make alternative arrangements for supply of water at the risk and cost of contractor(s) if the arrangements made by the contractor(s) for procurement of water are in the opinion of the Engineer-in- Charge, unsatisfactory.
5.4	Deleted
6.0	Measurement and Payment
6.1	Measurements of Work Done:

Engineer in charge shall, except as otherwise provided, ascertain and determine by measurement the value in accordance with the contract of work done.

All measurement of all items having financial value shall be entered in Computerized Measurement Book and/or level field book so that a complete record is obtained of all works performed under the contract.

All measurements and levels shall be taken jointly by the Engineer in charge or his authorized representative and by the contractor or his authorized representative from time to time during the progress of the work and such measurements shall be signed and dated by the Engineer and the contractor or their representatives in token of their acceptance. If the contractor objects to any of the measurements recorded, a note shall be made to that effect with reason and signed by both the parties.

If for any reason the contractor or his authorized representative is not available and the work of recording measurements is suspended by the Employer or his representative, the Employer shall not entertain any claim from contractor for any loss or damages on this account. If the contractor or his authorized representative does not remain present at the time of such measurements after the contractor or his authorized representative has been given a notice in writing three (3) days in advance or fails to countersign or to record objection within a week from the date of the measurement, then such measurements recorded in his absence by the Engineer in Charge or his representative shall be deemed to be accepted by the Contractor.

The contractor shall, without extra charge, provide all assistance with every appliance, labour and other things necessary for measurements and recording levels.

Except where any general or detailed description of the work expressly shows to the contrary, measurements shall be taken in accordance with the procedure set forth in the specifications notwithstanding any provision in the relevant Standard Method of measurement or any general or local custom. In the case of items which are not covered by specifications, measurements shall be taken in accordance with the relevant standard method of measurement issued by the Bureau of Indian Standards and if for any item no such standard is available then a mutually agreed method shall be followed.

The Contractor shall give not less than seven days' notice to the Employer or his authorized representative in-charge of the work before covering up or otherwise placing beyond the reach of measurement any work in order that the same may be measured and correct dimensions thereof be taken before the same is covered up or placed beyond the reach of measurement and shall not cover up and place beyond reach of measurement any work without consent in writing of the Employer or his authorized representative in-charge of the work who shall within the aforesaid period of seven days inspect the work, and if any work shall be covered up or placed beyond the reach of measurements without such notice having been given or the Employer's consent being obtained in writing the same shall be uncovered at the Contractor's expense, or in default thereof no payment or allowance shall be made for such work or the materials with which the same was executed.

Employer or his authorized representative may cause either themselves or through another officer of the department to check the measurements recorded jointly or otherwise as aforesaid and all provisions stipulated herein above shall be applicable to such checking of measurements or levels.

It is also a term of this contract that recording of measurements of any item of work in the measurement book and/or its payment in the interim, on account or final bill shall not be considered as conclusive evidence as to the sufficiency of any work or material to which it

	relates nor shall it relieve the Contractor from liabilities from any over measurement or defects noticed till completion of the defects liability period.
6.2	Deleted
6.3	<p>Completion Certificate And Completion Plans:</p> <p>Within 10 days of the completion of the work, the Contractor shall give notice of such completion to the Employer and within 30 days of the receipt of such notice the Employer shall inspect the work and if there is no defect in the work, shall furnish the Contractor with a final certificate of completion, otherwise a provisional certificate of physical completion indicating defects (a) to be rectified by the contractor and/or (b) for which payment will be made at reduced rates, shall be issued. But no final certificate of completion shall be issued, nor shall the work be considered to be complete until the contractor shall have removed from the premises on which the work shall be executed all scaffolding, surplus materials, rubbish and all huts and sanitary arrangements required for his/their work people on the site in connection with the execution of the works as shall have been erected or constructed by the contractor(s) and cleaned off the dirt from all wood work, doors, windows, walls, floor or other parts of the building, in, upon, or about which the work is to be executed or of which he may have had possession for the purpose of the execution thereof, and not until the work shall have been measured by the Employer. If the contractor shall fail to comply with the requirements of this Clause as to removal of scaffolding, surplus materials and rubbish and all huts and sanitary arrangements as aforesaid and cleaning off dirt on or before the date fixed for the completion of work, the Employer may at the expense of the contractor remove such scaffolding, surplus materials and rubbish etc., and dispose of the same as he thinks fit and clean off such dirt as aforesaid, and the contractor shall have no claim in respect of scaffolding or surplus materials as aforesaid except for any sum actually realized by the sale thereof.</p>
6.4	<p>Payment of Final Bill:</p> <p>The final bill shall be submitted by the Contractor in the same manner as specified in interim bills within one months of physical completion of the work or within one month of the date of the final certificate of completion furnished to the Employer whichever is earlier. No further claims shall be made by the Contractor after submission of the final bill and these shall be deemed to have been waived and extinguished. Payments of those items of the bill in respect of which there is no dispute and of items in dispute, for quantities and rates as approved by Employer, will, as far as possible be made within a period of three months, the period being reckoned from the date of receipt of the bill by the Engineer, complete with account of dismantled materials.</p>
6.5	<p>Advance:</p> <p>Advance as per extant rule in GFR and procurement manual will be admissible.</p>
6.6	Deleted
6.7	Deleted
7.0	Observance of Labour Regulation
7.1	<p>Recovery Of Compensation Paid To Workmen:</p> <p>In every case in which by virtue of the provisions sub-section (1) of Section 12, of the Workmen's Compensation Act, 1923, Government is obliged to pay compensation to a</p>

	<p>workman employed by the contractor, in execution of the works, Government will recover from the contractor, the amount of the compensation so paid; and, without prejudice to the rights of the Government under sub-section (2) of Section 12, of the said Act, Government shall be at liberty to recover such amount or any part thereof by deducting it from the security deposit or from any sum due by Government to the contractor whether under this contract or otherwise. Government shall not be bound to contest any claim made against it under sub-section (1) Section 12, of the said Act, except on the written request of the contractor and upon his giving to Government full security for all costs for which Government might become liable in consequence of contesting such claim.</p>
7.2	<p>Ensuring Payment and Amenities To Workman, If Contractor Fails:</p> <p>In every case in which by virtue of the provisions of the Contract Labour (Regulation and Abolition) Act, 1970, and of the Contract Labour (Regulation and Abolition) Central Rules, 1971, Government is obliged to pay any amounts of wages to a workman employed by the contractor in execution of the works, or to incur any expenditure in providing welfare and health amenities required to be provided under the above said Act and the rules under Clause 7.10 or under the Contractor's Labour Regulations, or under the Rules framed by Government from time to time for the protection of health and sanitary arrangements for workers employed by Contractors, Government will recover from the contractor, the amount of wages so paid or the amount of expenditure so incurred; and without prejudice to the rights of the Government under sub-section(2) of Section 20, and sub-section (4) of Section 21, of the Contract Labour (Regulation and Abolition) Act, 1970, Government shall be at liberty to recover such amount or any part thereof by deducting it from the security deposit or from any sum due by Government to the contractor whether under this contract or otherwise Government shall not be bound to contest any claim made against it under sub-section (1) of Section 20, sub-section (4) of Section 21, of the said Act, except on the written request of the contractor and upon his giving to the Government full security for all costs for which Government might become liable in contesting such claim.</p>
7.3	<p>Labour Laws to be Complied</p> <p>The Contractor shall obtain a valid licence under the Contract Labour (R&A) Act 1970, and the Contract Labour (Regulation and Abolition) Central Rules 1971, before the commencement of the work, and continue to have a valid license until the completion of the work. The contractor shall also abide by the provisions of the Child Labour (Prohibition and Regulation) Act, 1986.</p> <p>The contractor shall also comply with the provisions of the building and other Construction Workers (Regulation of Employment & Conditions of Service) Act, 1996 and the building and other Construction Workers Welfare Cess Act, 1996.</p> <p>Any failure to fulfil these requirements shall attract the penal provisions of this contract arising out of the resultant non-execution of the work.</p> <p>No labour below the age of fourteen years shall be employed on the work.</p>
7.4	<p>Payment of Wages:</p> <p>(i) The Contractor shall pay to labour employed by him either directly or through sub-contractors, wages not less than fair wages as defined in Contractor's Labour Regulations or as per the provisions of the Contract Labour (Regulation and Abolition) Act 1970 and the contract Labour (Regulation and Abolition) Central Rules, 1971, wherever applicable.</p>

	<ul style="list-style-type: none"> (ii) The Contractor shall, notwithstanding the provisions of any contract to the contrary, cause to be paid fair wage to labour indirectly engaged on the work, including any labour engaged by his subcontractors in connection with the said work, as if the labour had been immediately employed by him. (iii) In respect of all labour directly or indirectly employed in the works for performance of the contractor's part of this contract, the Contractor shall comply with or cause to be complied with the contractor's Labour Regulations made by Government from time to time in regard to payment of wages, wage period, deductions from wages recovery of wages not paid and deductions unauthorisedly made, maintenance of wage books or wage slips, publication of scale of wages and other terms of employment, inspection and submission of periodical returns and all other matters of the like nature or as per the provisions of the Contract Labour (Regulation and Abolition) Act 1970, and the Contract Labour (Regulation and Abolition) Central Rules, 1971, wherever applicable. (iv) (a) The Employer concerned shall have the right to deduct from the moneys due to the contractor any sum required or estimated to be required for making good the loss suffered by a worker or workers by reason of non-fulfilment of the conditions of the contract forth benefit of the workers, non-payment of wages or of deductions made from his or their wages which are not justified by their terms of the contract or non-observance of the Regulations. (b) Under the provision of Minimum Wages (Central) Rules 1950, the contractor is bound to allow to the labours directly or indirectly employed in the works one day rest for 6 days continuous work and pay wages at the same rate as for duty. In the event of default, the Employer shall have the right to deduct the sum or sums not paid on account of wages for weekly holidays to any labours and pay the same to the persons entitled thereto from any money due to the contractor by the Employer concerned. (v) The contractor shall comply with the provisions of the Payment of Wages Act, 1936, Minimum Wages Act, 1948, Employees Liability Act, 1938, Workmen's Compensation Act, 1923, Industrial Disputes Act, 1947, Maternity Benefits Act, 1961, and the Contractor's Labour (Regulation and Abolition) Act 1970, or the modifications thereof or any other laws relating thereto and the rules made there under from time to time. (vi) The contractor shall indemnify and keep indemnified Government against payments to be made under and for the observance of the laws aforesaid and the Contractor's Labour Regulations without prejudice to his right to claim indemnity from his sub-contractors. (vii) The laws aforesaid shall be deemed to be a part of this contract and any breach thereof shall be deemed to be a breach of this contract. (viii) Whatever is the minimum wage for the time being, or if the wage payable is higher than such wage, such wage shall be paid by the Contractor to the workmen directly without the intervention of Jamadar and that Jamadar shall not be entitled to deduct or recover any amount from the minimum wage payable to the workmen as and by way of commission or otherwise. (ix) The contractor shall ensure that no amount by way of commission or otherwise is deducted or recovered by the Jamadar from the wage of workmen.
7.5	Arrangement for Safety Provisions

	<p>In respect of all labour directly or indirectly employed in the work for the performance of the Contractor's part of this contract, the Contractor shall at his own expense arrange for the safety provisions as per. Safety Code framed from time to time and shall at his own expense provide for all facilities in connection therewith. In case the Contractor fails to make arrangement and provide necessary facilities as aforesaid, he shall be liable to pay a penalty of Rs.500/- for each default and in addition the Employer shall be at liberty to make arrangement and provide facilities as aforesaid and recover the costs incurred in that behalf from the Contractor.</p>
<p>7.6</p>	<p>Submission Of Labour Return</p> <p>The contractor shall submit on or before the 1st day of February following the end of year to which it relates, to the Employer a true statement showing in respect of thesecondhalfoftheprecedingmonthandthefirsthalfofthecurrentmonthrespectively:</p> <ol style="list-style-type: none"> (1) the number of labourers employed by him on the work, (2) their working hours, (3) the wages paid to them, (4) the accidents that occurred during the said fortnight showing the circumstances under which they happened and the extent of damage and injury caused by them, and (5) the number of female workers who have been allowed maternity benefit according to Clause 7.8 and the amount paid to them. <p>Failing which the Contractor shall be liable to pay to Government, a sum not exceeding Rs.500/- for each default or materially incorrect statement. The decision of the Employer shall be final in deducting from any bill due to the Contractor the amount levied as fine and be binding on the contractor.</p>
<p>7.7</p>	<p>Rules Framed By Govt. To Be Complied</p> <p>In respect of all labour directly or indirectly employed in the works for the performance of the Contractor's part of this contract, the Contractor shall comply with or cause to be complied with all the rules framed by Government from time to time for the protection of health and sanitary arrangements for workers employed by the contractors.</p>
<p>7.8</p>	<p>Leave And Pay Regulations</p> <p>Leave and pay during leave shall be regulated as follows:</p> <ol style="list-style-type: none"> 1. Leave: <ol style="list-style-type: none"> (i) in the case of delivery - maternity leave not exceeding 8 weeks, 4 weeks up to and including the day of delivery and 4 weeks following that day, (ii) in the case of miscarriage – up to 3 weeks from the date of miscarriage. 2. Pay: <ol style="list-style-type: none"> (i) in the case of delivery - leave pay during maternity leave will be at the rate of the women's average daily earnings, calculated on total wages earned on the days when full time work was done during a period of 3 months immediately preceding the date on which she gives notice that she expects to be confined or at the rate of Rupee one only a day whichever is greater. (ii) in the case of miscarriage - leave pay at the rate of average daily earning

	<p>calculated on the total wages earned on the days when full time work was done during a period of three months immediately preceding the date of such miscarriage.</p> <p>3. Conditions for the grant of Maternity Leave: No maternity leave benefit shall be admissible to a woman unless she has been employed for a total period of not less than six months immediately preceding the date on which she proceeds on leave.</p> <p>4. The contractor shall maintain a register of Maternity (Benefit) in the Prescribed Form, and the same shall be kept at the place of work.</p>
<p>7.9</p>	<p>Default of any of the Provisions of Contractors' Labour Regulations</p> <p>In the event of the contractor(s) committing a default or breach of any of the provisions , Contractor's Labour Regulations and Model Rules for the protection of health and sanitary arrangements for the workers as amended from time to time or furnishing any information or submitting or filing any statement under the provisions of the above Regulations and Rules which is materially incorrect, he/they shall, without prejudice to any other liability, pay to the Govt. a sum not exceeding Rs500/- for every default, breach or furnishing, making, submitting, filing such materially incorrect statements and in the event of the contractor(s) defaulting continuously in this respect, the penalty may be enhanced to Rs.200/- per day for each day of default subject to a maximum of 5 per cent of the estimated cost of the work put to tender. The decision of the Employer shall be final and binding on the parties.</p> <p>Should it appear to the Employer that the contractor(s) is/ are not properly observing and complying with the provisions of the Contractor's Labour Regulations and Model Rules and the provisions of the Contract Labour (Regulation and Abolition) Act 1970, and the Contract Labour (R& A) Central Rules 1971, for the protection of health and sanitary arrangements for work-people employed by the contractor(s) (hereinafter referred as "the said Rules") the Employer shall have power to give notice in writing to the contractor(s) requiring that the said Rules be complied with and the amenities prescribed therein be provided to the work-people within a reasonable time to be specified in the notice. If the contractor(s) shall fail within the period specified in the notice to comply with and/ observe the said Rules and to provide the amenities to the work-people as aforesaid, the Employer shall have the power to provide the amenities hereinbefore mentioned at the cost of the contractor(s). The contractor(s) shall erect, make and maintain at his/their own expense and to approved standards all necessary tents and sanitary arrangements required for his/their work-people on the site in connection with the execution of the works, and if the same shall not have been erected or constructed, according to approved standards, the Employer shall have power to give notice in writing to the contractor(s) requiring that the said tents and sanitary arrangements be remodelled and/or reconstructed according to approved standards, and if the contractor(s) shall fail to remodel or reconstruct such huts and sanitary arrangements according to approved standards within the period specified in the notice, the Employer shall have the power to remodel or reconstruct such huts and sanitary arrangements according to approved standards at the cost of the contractor(s).</p>
<p>7.10</p>	<p>Provision Of Tents, Water Supply to the Labourer</p> <p>The contractor(s) shall at his/their own cost provide his/their labour with following facilities</p> <p>a) Sufficient numbers of tents.</p> <p>b) Sufficient numbers of latrines and urinals covered by tents.</p>

	<p>c) Sufficient quantity of water for drinking and other purposes. d) Proper drainage and sanitation.</p>
7.11	<p>Removal of Contractor's Employee</p> <p>The Employer may require the contractor to dismiss or remove from the site of the work any person or persons in the contractors' employ upon the work who may be incompetent or misconduct himself and the contractor shall forthwith comply with such requirements.</p>
8.0	<p>Operation of contract</p>
8.1	<p>Time and Extension for Delay</p> <p>The time allowed for execution of the Works as specified in the Bidding data or the extended time in accordance with these conditions shall be the essence of the Contract. The execution of the works shall commence from such time period as mentioned in letter of acceptance or from the date of handing over of the site whichever is later. If the Contractor commits default in commencing the execution of the work as aforesaid, Government shall without prejudice to any other right or remedy available in law, be at liberty to forfeit the earnest money & performance guarantee absolutely.</p> <p>As soon as possible after the Contract is concluded the Contractor shall submit a Time and Progress Chart and get it approved by the Employer. It shall indicate the forecast of the dates of commencement and completion of various trades of sections of the work and may be amended as necessary by agreement between the Employer and the Contractor and further to ensure good progress during the execution of the work, the contractor shall in all cases complete the work as per the schedule.</p> <p>If the work(s) be delayed by:</p> <ul style="list-style-type: none"> (i) force majeure events, or (ii) abnormally bad weather, or (iii) serious loss or damage by fire, or (iv) civil commotion, local commotion of workmen, strike (excluding by Party's employees) or lockout (excluding by Party's employees), affecting any of the trades employed on the work , or (v) delay on the part of other contractors or tradesmen engaged by Employer in executing work not forming part of the Contract, or (vi) any other cause which, in the absolute discretion of the authority mentioned in Bidding Data is beyond the Contractor's control and not brought about at the instance of the Contractor claiming to be affected by such event. <p>then upon the happening of any such event causing delay, the Contractor shall immediately give notice thereof in writing to the Employer but shall nevertheless use constantly his best endeavours to prevent or make good the delay and shall do all that may be reasonably required to the satisfaction of the Employer to proceed with the works.</p> <p>Request for rescheduling of work and extension of time, to be eligible for consideration, shall be made by the Contractor in writing within 14 days of the happening of the event causing delay on the prescribed form. The Contractor may also, if practicable, indicate in such a request the period for which extension is desired.</p> <p>In any such case the authority mentioned in Bidding Data may give a fair and reasonable extension of time. Such extension shall be communicated to the Contractor by the</p>

	Employer in writing, within 2 months of the date of receipt of such request. Non application by the contractor for extension of time shall not be a bar for giving a fair and reasonable extension by the Employer and this shall be binding on the contractor.
8.2	<p>Compensation For Delay</p> <p>If the contractor fails to maintain the required progress in terms of clause 8.1 or to complete the work and clear the site on or before the contract or extended date of completion, he shall, without prejudice to any other right or remedy available under the law to the Government on account of such breach, pay as agreed compensation the amount calculated at the rates stipulated below as the competent authority(whose decision in writing shall be final and binding) may decide on the amount of tendered value of the work for every completed day/week (as applicable) that the progress remains below that specified in Clause 8.1 or that the work remains incomplete.</p> <p>This will also apply to items or group of items for which a separate period of completion has been specified.</p> <p>Compensation @ 0.5% (zero point five percent) of the total contract value per week of delay and part there of subject to maximum of 10% of contract value.</p>
8.3	<p>When Contract Can Be Determined</p> <p>Subject to other provisions contained in this clause, the Employer may, without prejudice to his any other rights or remedy against the Contractor in respect of any delay, inferior workmanship, any claims for damages and/or any other provisions of this contract or otherwise, and whether the date of completion has or has not elapsed, by notice in writing absolutely determine the contract in any of the following cases:</p> <ul style="list-style-type: none"> (i) If the contractor having been given by the Employer a notice in writing to rectify, reconstruct or replace any defective work or that the work is being performed in an inefficient or otherwise improper or un-workman like manner shall omit to comply with the requirement of such notice for a period of 7 days thereafter. (ii) If the contractor being a company shall pass a resolution or the court shall make an order that the company shall be wound up or if a receiver or a manager on behalf of a creditor shall be appointed or if circumstances shall arise which entitle the court or the creditor to appoint a receiver or a manager or which entitle the court to make a winding up order. (iii) If the contractor has, without reasonable cause, suspended the progress of the work or has failed to proceed with the work with due diligence so that in the opinion of the Employer (which shall be final and binding) he will be unable to secure completion of the work by the date for completion and continues to do so after a notice in writing of seven days from the Employer. (iv) If the contractor fails to complete the work within the stipulated date or items of work with individual date of completion, if any stipulated, on or before such date(s) of completion and does not complete them within the period specified in a notice given in writing in that behalf by the Employer. (v) If the contractor persistently neglects to carry out his obligations under the contract and/or commits default in complying with any of the terms and conditions of the contract and does not remedy it or take effective steps to remedy it within 7 days after a notice in writing is given to him in that behalf by the Employer. (vi) If the contractor commits any acts mentioned in Clause 2.1 hereof; or

	<p>(vii) If the work is not started by the contractor within 1/8th of the stipulated time. When the contractor has made himself liable for action under any one or more of the cases aforesaid, the Employer on behalf of the President of India shall have powers:</p> <p>a) To determine or rescind the contract as aforesaid (of which termination or rescission notice in writing to the contractor under the hand of the Employer shall be conclusive evidence). Upon such determination or rescission, the Earnest Money Deposit, Security Deposit already recovered and Performance Guarantee under the contract shall be liable to be forfeited and shall be absolutely at the disposal of the Government/ the Employer.</p> <p>b) After giving notice to the contractor to measure up the work of the contractor and to take such whole, or the balance or part thereof, as shall be un-executed out of his hands and to give it to another contractor to complete the work. The contractor, whose contract is determined or rescinded as above, shall not be allowed to participate in the tendering process for the balance work.</p> <p>In the event of above courses being adopted by the Employer, the contractor shall have no claim to compensation for any loss sustained by him by reasons of his having purchased or procured any materials or entered into any engagements or made any advances on account or with a view to the execution of the work or the performance of the contract. And in case action is taken under any of the provision aforesaid, the contractor shall not be entitled to recover or be paid any sum for any work thereof or actually performed under this contract unless and until the Employer has certified in writing the performance of such work and the value payable in respect thereof and he shall only be entitled to be paid the value so certified.</p>
<p>8.4</p>	<p>Foreclosure of Contract due to Abandonment or Reduction In Scope of Work</p> <p>If at any time after acceptance of the bid, the Employer/ Government shall decide to abandon or reduce the scope of the works for any reason whatsoever and hence not require the whole or any part of the works to be carried out, the Employer shall give notice in writing to that effect to the contractor and the contractor shall act accordingly in the matter. The contractor shall have no claim to any payment of compensation or otherwise whatsoever, on account of any profit or advantage which he might have derived from the execution of the works in full but which he did not derive in consequence of the foreclosure of the whole or part of the works.</p> <p>The contractor shall be paid at contract rates full amount for works executed at site and, in addition, reasonable amount as certified by the Engineer for the items hereunder mentioned which could not be utilised on the work to the full extent in view of the foreclosure:</p> <p>(i) Any expenditure incurred on preliminary site work, (ii) Government shall have the option to take over contractor's materials or any part thereof either brought to site or of which the contractor is legally bound to accept delivery from suppliers (for incorporation in or incidental to the work) provided, however, Government shall be bound to take over the materials or such portions thereof as the contractor does not desire to retain. For materials taken over or to be</p>

	<p>taken over by Government, cost of such materials as detailed by Engineer shall be paid. The cost shall, however, take into account purchase price, cost of transportation and deterioration or damage which may have been caused to materials whilst in the custody of the contractor.</p> <p>(iii) Reasonable compensation for transfer of T & P from site to contractor's permanent stores or to his other works, whichever is less. If T & P are not transported to either of the said places, no cost of transportation shall be payable.</p> <p>(iv) Reasonable compensation for repatriation of contractor's site staff and imported labour to the extent necessary.</p> <p>The contractor shall, if required by the Engineer furnish to him books of account, wage books, time sheets and other relevant documents and evidence as may be necessary to enable him to certify the reasonable amount payable under this condition.</p> <p>The reasonable amount of items on (i), (iii) and (iv) above shall not be in excess of 2% of the cost of the work remaining incomplete on the date of closure, i.e. total stipulated cost of the work as per accepted bid less the cost of work actually executed under the contract and less the cost of contractor's materials at site taken over by the Government as per item (ii) above. Provided always that against any payments due to the contractor on this account or otherwise, the Employer shall be entitled to recover or be credited with any outstanding balances due from the contractor for advance paid in respect of any tool, plants and materials and any other sums which at the date of termination were recoverable by the Government from the contractor under the terms of the contract.</p>
<p>8.5</p>	<p>Cancellation Of Contract In Full Or Part</p> <p>If Contractor:</p> <p>(i) at any time makes default in proceeding with the works or any part of the work with the due diligence and continues to do so after a notice in writing of 7 days from the Employer; or</p> <p>(ii) commits default to complying with any of the terms and conditions of the contract and does not remedy it or take effective steps to remedy it within 7 days after a notice in writing is given to him in that behalf by the Employer; or</p> <p>(iii) fails to complete the works or items of work with individual dates of completion, on or before the date(s) of completion, and does not complete them within the period specified in a notice given in writing in that behalf by the Employer; or</p> <p>(iv) shall offer or give or agree to give to any person in Government service or to any other person of his behalf any gift or consideration of any kind as an inducement or reward for doing or forbearing to do or for having done or forborne to do any act in relation to the obtaining or execution of this or any other contract for Government; or</p> <p>(v) shall enter into a contract with Government in connection with which commission has been paid or agreed to be paid by him or to his knowledge, unless the particulars of any such commission and the terms of payment thereof have been previously disclosed in writing to the Accepting Authority/Employer; or</p> <p>(vi) shall obtain a contract with Government as a result of wrong tendering or other non-bonafide methods of competitive tendering; or</p> <p>(vii) being an individual, or if a firm, any partner thereof shall at any time be adjudged insolvent or have a receiving order or order for administration of his estate made</p>

against him or shall take any proceedings for liquidation or composition (other than a voluntary liquidation for the purpose of amalgamation or reconstruction) under any Insolvency Act for the time being in force or make any conveyance or assignment of his effects or composition or arrangement for the benefit of his creditors or purport so to do, or if any application be made under any Insolvency Act for the time being in force for the sequestration of his estate or if a trust deed be executed by him for benefit of his creditors; or

- (viii) being a company, shall pass a resolution or the Court shall make an order for the winding up of the company, or a receiver or manager on behalf of the debenture holders or otherwise shall be appointed or circumstances shall arise which entitle the Court or debenture holders to appoint a receiver or manager; or
- (ix) shall suffer an execution being levied on his goods and allow it to be continued for a period of 21 days; or
- (x) assigns, transfers, sublets (engagement of labour on a piece-work basis or of labour with materials not to be incorporated in the work, shall not be deemed to be subletting) or otherwise parts with or attempts to assign, transfer sublet or otherwise parts with the entire works or any portion thereof without the prior written approval of the Accepting Authority;

The Accepting Authority may, without prejudice to any other right or remedy which shall have accrued or shall accrue hereafter to Government, by a notice in writing to cancel the contract as a whole or only such item of work in default from the Contract.

The Employer shall on such cancellation by the Accepting Authority have powers to:

- (i) take possession of the site and any materials, constructional plant, implements, stores, etc., thereon; and/or
- (ii) carry out the incomplete work by any means at the risk and cost of the contractor.

On cancellation of the contract in full or in part, the Employer shall determine what amount, if any, is recoverable from the contractor for completion of the works or part of the works or in case the works or part of the works is not to be completed, the loss or damage suffered by Government. In determining the amount, credit shall be given to the contractor for the value of the work executed by him up to the time of cancellation, the value of contractor's materials taken over and incorporated in the work and use of plant and machinery belonging to the contractor.

Any excess expenditure incurred or to be incurred by Government in completing the works or part of the works or the excess loss or damages suffered or may be suffered by Government as aforesaid after allowing such credit shall without prejudice to any other right or remedy available to Government in law be recovered from any moneys due to the contractor on any account, and if such moneys are not sufficient, the contractor shall be called upon in writing and shall be liable to pay the same within 30 days.

If the contractor shall fail to pay the required sum within the aforesaid period of 30 days, the Employer shall have the right to sell any or all of the contractors' unused materials, constructional plant, implements, temporary buildings, etc. and apply the proceeds of sale thereof towards the satisfaction of any sums due from the contractor under the contract and if thereafter there be any balance outstanding from the contractor, it shall be recovered in

	<p>accordance with the provisions of the contract.</p> <p>Any sums in excess of the amounts due to Government and unsold materials, constructional plant, etc., shall be returned to the contractor, provided always that if cost or anticipated cost of completion by Government of the works or part of the works is less than the amount which the contractor would have been paid had he completed the works or part of the works, such benefit shall not accrue to the contractor.</p>
8.6	<p>Termination Of Contract After Death Of Contractor</p> <p>Without prejudice to any of the rights or remedies under this contract if the Contractor dies, the Employer on behalf of the President of India shall have the option of terminating the contract without compensation to the Contractor.</p>
9.0	<p>Dispute Resolution Mechanism</p> <p>Except where otherwise provided in the contract, all questions and disputes relating to the meaning of the specifications, design, drawings and instructions here-in before mentioned and as to the quality of workmanship or materials used on the work or as to any other question, claim, right, matter or thing whatsoever in any way arising out of or relating to the contract, designs, drawings, specifications, estimates, instructions, orders or these conditions or otherwise concerning the works or the execution or failure to execute the same whether arising during the progress of the work or after the cancellation, termination, completion or abandonment thereof shall be dealt with as mentioned hereinafter:</p>
9.1	<p>Dispute Resolution Board</p> <p>If any dispute arises between the Employer and the Contractor in connection with, or arising out of, the Contract or the execution of the Works, whether during the execution of the Works or after their completion and whether before or after the repudiation or other termination of the Contract, including any disagreement by either party with any action, inaction, opinion, instruction, determination, certificate or valuation of the Engineer, the matter in dispute shall, in the first place, be referred to the dispute resolution board here in after called “the board.”</p> <p>The board shall comprise of members as defined in the bidding data. The board at its discretion may co-opt any other officer if in its opinion it may help in resolving the dispute. Either party may refer a dispute to the Board. The board shall give a decision in writing within 30 days of reference of dispute.</p> <p>Either party may refer a written decision of the board. If neither party refers the disputes to arbitration within 30 days, the board’s decision will be final and binding.</p> <p>Employer at its discretion may change any of the member of the board.</p>
9.2	<p>Arbitration</p> <p>Any dispute in respect of which the recommendation, if any, of the dispute resolution board has not become final and binding shall be finally settled in accordance with the provisions of the Arbitration and Conciliation Act, 1996 or any statutory modifications or re-enactment thereof and the rules made there under and for the time being in force. The arbitrator shall have full power to open up, review and revise any decision, and any recommendation of the conciliator related to the dispute.</p> <p>A Sole Arbitrator shall be appointed by the appointing authority as defined in contract data</p>

	<p>within 30 days of receipt of request from either party. If the arbitrator so appointed is unable or unwilling to act or resigns his appointment or vacates his office due to any reason whatsoever, another arbitrator shall be appointed in the manner aforesaid. Such person shall be entitled to proceed with same reference from the stage at which it was left by his predecessor.</p> <p>It is a term of this contract that the arbitrator shall adjudicate only such disputes as are referred to him by the appointing authority and give separate award against each dispute and claim referred to him and in all cases the arbitrator shall give reasons for the award. If any fees is payable to the arbitrator, these shall be paid equally by both the parties.</p> <p>It is also a term of the contract that the arbitrator shall be deemed to have entered on the reference on the date he issues notice to both the parties calling them to submit their statement of claims and counterstatement of claims. The venue of the arbitration shall be such place in India as may be fixed by the arbitrator in his sole discretion.</p> <p>Neither party shall be limited in the proceedings before such arbitrator to the evidence or arguments put before the conciliator for the purpose of obtaining its recommendation/decision. No recommendation shall disqualify conciliator or Employer from being called as a witness and giving evidence before the arbitrator on any matter whatsoever relevant to the dispute.</p>
<p>9.3</p>	<p><u>Jurisdiction of Court</u> The Courts and High Court located within the administrative and operational area of the concerned Regional Offices shall have the sole jurisdiction for adjudication of any dispute arising out of the contract.</p>
<p>10</p>	<p>Miscellaneous provisions</p> <p>(i) “Nothing contained in this Contract shall be construed as establishing or creating between the Parties, a relationship of master and servant or principal and agent.</p> <p>(ii) Any failure or delay on the part of any Party to exercise right or power under this Contract shall not operate as waiver thereof.</p> <p>(iii) The Contractor/Consultant shall notify the Employer/ the Government of India of any material change in their status, in particular, where such change would impact on performance of obligations under this Contract.</p> <p>(iv) Each member/constituent of the Contractor/Consultant, in case of a consortium, shall be jointly and severally liable to and responsible for all obligations towards the Employer/Government for performance of works/services including that of its Associates/Sub Contractors under the Contract.</p> <p>(v) The Contractor/Consultant shall at all times indemnify and keep indemnified the Employer/Government of India against all claims/damages etc. for any infringement of any Intellectual Property Rights (IPR) while providing its services under the Project.</p> <p>(vi) The Contractor/Consultant shall at all times indemnify and keep indemnified the Employer/Government of India against any claims in respect of any damages or compensation payable in consequences of any accident or injury sustained or suffered by its (the Contractor’s/Consultant’s) employees or agents or by any other third Party resulting from or by any action, omission or operation conducted by or on behalf of the Contractor/Consultant.</p> <p>(vii) The Contractor/ Consultant shall at all times indemnify and keep indemnified the Employer/Government of India against any and all claims by Employees, Workman, Contractors, sub-contractors, suppliers, agent(s), employed engaged or otherwise working for the Contractor, in respect of wages, salaries, remuneration,</p>

	<p>compensation or the like.</p> <p>(viii) All claims regarding indemnity shall survive the termination or expiry of the Contract.</p> <p>(ix) It is acknowledged and agreed by all Parties that there is no representation of any type, implied or otherwise, of any absorption, regularization, continued engagement or concession or preference for employment of persons engaged by the (Contractor/Consultant) for any engagement, service or employment in any capacity in any office or establishment of the Government of India or the Employer.</p>
11	<p>Laws Governing the Contract:</p> <p>This contract shall be governed by the Laws of India for the time being in force.</p>

SECTION- IV
SPECIAL CONDITIONS
OF
CONTRACT
(SCC)

SECTION- IV			
SPECIAL CONDITIONS OF CONTRACT (SCC)			
The following Special conditions of contract shall apply for this Contract. These special conditions will modify/ substitute/ supplement the corresponding General Conditions of Contract (GCC) incorporated in Section III. The corresponding GCC clause numbers have also been indicated.			
In case of any conflict between the provision in the GCC and that in the SCC, the provision contained in the SCC shall prevail.			
S. No.	GCC Clause Number	Subject Matter	SCC Provision
1.	1.5	Signing of Contract	In addition to safety code provided in Section- XVI, the guidelines issued by Honourable Supreme Court in case No. WP(C) 36/2009 on 11.02.2010 shall be applicable for this contract.
2.	2.6	Conditions for Reimbursement of Levy/Taxes, if Levied after Receipt of Tenders	Any modification of GST by the Government the difference will be paid/ recovered to/from the contractor.
3.	3.1	Performance Guarantee	<p>1. The Contractor required submitting an initial Performance Security/ Guarantee amounting to 3% of the Contract Price within 21 days of issue of letter of Acceptance as specified in the GCC clause 3.1. The Performance Security shall be valid up to the stipulated date of completion of Drilling and completion of all the PZ plus twelve months thereafter.</p> <p>The performance security shall be released upon fulfillment of the following conditions/ submission of following documents:-</p> <ol style="list-style-type: none"> Work Completion certificate No Claim Certificate for the completed part of work Satisfactory completion of Defect Liability Period. Any other documents required as per contract agreement and government norms. <p><u>Work Completion Certificate:-</u> Shall be issued after completion of the Piezometer and submission of all necessary requirements as per the contract.</p>

4.	3.2	Retention Money/ Security Deposit	5 % (Five percent) of each running bill (periodic/ interim payment) will be withheld as Security Deposit/ retention money until final acceptance. The Security Deposit/ retention money will be release with the Final payment after issuance of Work Completion Certificate.												
5.	4	Execution of Work	<p>In addition to the compliance under GCC Clause 4, Scope of work, relevant technical specifications, the contractor shall extend full cooperation with CGWB to achieve the deliverables as per the best workmanship is up to the standards followed in the Industry with following QAP.</p> <p style="text-align: center;"><u>Quality Assurance Plan (QAP)</u></p> <p>Following guidelines will be followed by CGWB in execution of works:-</p> <ol style="list-style-type: none"> 1. The work will be executed through the Regional Directors and Executive Engineers of the concerned Regions and Divisions. 2. The 'Executive Engineers will depute suitable persons not below the rank of Junior Engineer for measurement of work as per bill of quantities (BOQs) in Measurement Books in accordance with CPWD accounting system. 3. The Regional Directors will depute suitable persons for supervision of works involving scientific inputs such as assembly design, pumping tests, and collection of water samples etc. and countersign the measurements pertaining to these items and such other items which were measured during their presence. 4. The Measurement of work will be test checked by CGWB officials/officers of respective RPMU and NPMU in following manner :- <table border="1" data-bbox="743 1499 1385 1940"> <thead> <tr> <th data-bbox="743 1499 841 1570">S.No</th> <th data-bbox="841 1499 1122 1570">Designation/level of Officers/Officials</th> <th data-bbox="1122 1499 1385 1570">% of Work to be test checked</th> </tr> </thead> <tbody> <tr> <td data-bbox="743 1570 841 1759">1.</td> <td data-bbox="841 1570 1122 1759">Junior Engineer level (or above) officials/officers *Will also record measurement.</td> <td data-bbox="1122 1570 1385 1759">100%</td> </tr> <tr> <td data-bbox="743 1759 841 1864">2.</td> <td data-bbox="841 1759 1122 1864">Assistant Engineer level (or above) officers.</td> <td data-bbox="1122 1759 1385 1864">30%</td> </tr> <tr> <td data-bbox="743 1864 841 1940">3.</td> <td data-bbox="841 1864 1122 1940">Assistant Executive Engineer (or above).</td> <td data-bbox="1122 1864 1385 1940">20%</td> </tr> </tbody> </table>	S.No	Designation/level of Officers/Officials	% of Work to be test checked	1.	Junior Engineer level (or above) officials/officers *Will also record measurement.	100%	2.	Assistant Engineer level (or above) officers.	30%	3.	Assistant Executive Engineer (or above).	20%
S.No	Designation/level of Officers/Officials	% of Work to be test checked													
1.	Junior Engineer level (or above) officials/officers *Will also record measurement.	100%													
2.	Assistant Engineer level (or above) officers.	30%													
3.	Assistant Executive Engineer (or above).	20%													

			<table border="1"> <tr> <td>4.</td> <td>Executive Engineer/HOO of concerned Division</td> <td>10%</td> </tr> <tr> <td>5.</td> <td>Regional Director/HOO of concerned Region Office.</td> <td>5%</td> </tr> <tr> <td>6.</td> <td>Officers from NPMU</td> <td>2%</td> </tr> </table> <p>Note: A Site Hydro geologist of concerned Region Office (AHG or above) will supervise applicable scientific component of BoQ like Assembly Design & Lowering, Pump Test ,PYT, Slug Test, Logging, Water sampling etc.</p>	4.	Executive Engineer/HOO of concerned Division	10%	5.	Regional Director/HOO of concerned Region Office.	5%	6.	Officers from NPMU	2%
4.	Executive Engineer/HOO of concerned Division	10%										
5.	Regional Director/HOO of concerned Region Office.	5%										
6.	Officers from NPMU	2%										
			<p>5. The final payment for work will be made only on the personal certificate of the Executive Engineer/ Officer-In-Charge of the execution of the work in the format given below:</p> <p><i>"I, (Name of the Executive Engineer/ Officer-In-Charge), Executive Officer of (Name of the Work), am personally satisfied that the work has been executed as per the specifications laid down in the Contract Agreement and the workmanship is up to the standards followed in the Industry."</i></p> <p>The certificate will be countersigned by the concerned Regional Director.</p> <p>6. The work is to be monitored on regular basis by an Empowered Committee a Status Report has to be submitted by CGWB to DoWR, RD & GR on monthly basis, along with reasons to address the delay involved, if any.</p> <p>7. The composition of Empowered Committee(s) has been decided by the Competent Authority is as under:</p> <table border="1"> <tr> <td>I.</td> <td>Member under whose administrative control the Region falls.</td> <td>Chairman of the Committee</td> </tr> <tr> <td>II.</td> <td>Regional Director of the concerned Region</td> <td>Member</td> </tr> <tr> <td>II.</td> <td>Superintending Engineer</td> <td>Member</td> </tr> </table>	I.	Member under whose administrative control the Region falls.	Chairman of the Committee	II.	Regional Director of the concerned Region	Member	II.	Superintending Engineer	Member
I.	Member under whose administrative control the Region falls.	Chairman of the Committee										
II.	Regional Director of the concerned Region	Member										
II.	Superintending Engineer	Member										

			<table border="1" data-bbox="776 184 1341 296"> <tr> <td data-bbox="776 184 873 296"></td> <td data-bbox="873 184 1117 296">(to be nominated on case to case basis)</td> <td data-bbox="1117 184 1341 296"></td> </tr> </table> <p>The Empowered Committee(s) shall:</p> <ul style="list-style-type: none"> — Closely monitor the progress of each work — Assess the reasons for delays, if any — Recommend condonation of delays, if it is not due to fault of the contractor. — Recommend extension of time that is beyond the power!, of Regional Director/ Member. — Ensure that the work is being executed strictly as per the conditions of the contract. <p>All matters connected with any problems/ bottlenecks in execution of work should be reported to the Chairman of the Empowered Committee.</p>		(to be nominated on case to case basis)	
	(to be nominated on case to case basis)					
			<p>8. National Project Monitoring Unit (NPMU) for monitoring and implementation of the PIB project in CGWB has been constituted. The NPMU will function under the overall Guidance and Control of Member (South). The following broad activities will be carried out by the NPMU :-</p> <ol style="list-style-type: none"> I. Develop, implement and maintain Project Management information System (MIS). II. Prepare the list of the Monitoring indicators for the project III. Prepare the packages for implementation of the activities under the project. IV. Monitor and evaluate the internal operations of the Project V. Guide the operations of the Regional Project Monitoring Unit(RPMU) through providing advice and operating as a clearing house for issues (problems and solutions) raised by the RPMU/Field units VI. Monitor status of monitoring indicators VII. Evaluate the performance of the RPMU and the field offices of CGWB VIII. Develop procedures for regular monitoring of performance of the field units of CGWB IX. Preparation of procurement documents and certify technical specifications X. Act as a support and reference point for all Project-related procurement tasks. <p>9. On lines of the NPMU, a Regional Project Monitoring Unit (RPMU) will be constituted in each of the Regional Offices where the PIB</p>			

			<p>activities are proposed to be implemented. RPMU will function under the concerned Regional Director. The following major activities will be carried out by the RPMU:</p> <ol style="list-style-type: none"> I. Provide data and other inputs to NPMU for the Project Management Information System (MIS) II. Implementation of the project activities at the field level III. Monitoring and Evaluation of the internal operations of the Project and providing regular feedback to NPMU IV. Evaluate the performance of the contractors/ implementing agency and highlight the issues, if any, related to Project implementation <p>10. The progress reports concerning outsourcing works shall be sent to the Regional Director, who will coordinate with all the Empowered Committees and submit the status report to MoWR, RD & GR on monthly basis, along with reasons and remedial measures taken to address the delay involved, if any.</p>									
6.	4.2	Deviations/Variations Extent and Pricing	<p>During execution the employer reserves the right to increase or decrease the quantity of works maximum up to 20% without any change in the unit price and other terms and conditions.</p> <p>The total number of wells is 61 Piezometer wells as per BOQ.</p> <p>Authority to give approval for variation/deviation in items of BOQ Quantity with cost implications.</p> <table border="1"> <thead> <tr> <th>S. N.</th> <th>Authority</th> <th>Variation/ Deviation</th> </tr> </thead> <tbody> <tr> <td>1.</td> <td>Chairman, CGWB</td> <td>10 % (Subject to revised cost within the awarded value.)</td> </tr> <tr> <td>2</td> <td>DoWR, RD&GR</td> <td>Full Powers</td> </tr> </tbody> </table>	S. N.	Authority	Variation/ Deviation	1.	Chairman, CGWB	10 % (Subject to revised cost within the awarded value.)	2	DoWR, RD&GR	Full Powers
S. N.	Authority	Variation/ Deviation										
1.	Chairman, CGWB	10 % (Subject to revised cost within the awarded value.)										
2	DoWR, RD&GR	Full Powers										
7.	4.6	Employment of Technical Staff and Employees	<p>The contractor will have to employ at least one groundwater professional with minimum qualification of graduate degree in engineering/ master's degree in geosciences. Sufficient technical staff of skilled, semiskilled man power is required to be engaged in Rigs/ pump units deployed for construction of wells.</p>									

8.	5.1	Materials to be Provided by the Contractor	Advance samples need to be submitted for approval before in use. However, no well construction materials such as pipes, screens, and gravel shall be used in construction unless inspected and approved by Engineer-In-Charge.
		Rigs to be deployed by the contractor	The rigs to be deployed by the contractor for the drilling works shall be duly registered with either Central Ground Water Authority or State Ground Water Authority and document of registration to be submitted to the concerned Executive Engineer/ Head of Office of Division before deployment of rig for the works.
9.	6	Measurement and Payment	<p>The payment in respect of Piezometer wells shall be made by Executive Engineer/ Head of Office of Division VIII, Jammu.</p> <p><u>Payment for the Construction of Piezometer wells</u> Payment for the Construction of Piezometer wells The payment to the contractor will be made at each milestone for completed number of wells on the basis of actual measurements / verification of Running Account (RA) bill by concerned Division's Executive Engineer/Head of Office CGWB by deducting 5% of actual measurements / verification value as Retention Money/Security Deposit.</p> <p>On completion of each milestone the contractor shall submit the bill along with all data and BDR in prescribed format provided in the tender document. The bill submitted by the contractor shall be supported by verified well wise works executed. The Well is treated as complete only when all items of BOQ (including pumping test if specified in BOQ, BDR etc.) as ordered by employer site representative have been carried out and completed in all aspect and well is handed over to employer. In case of non achievement of milestone, the amount equivalent to 10% of the running bill amount passed for payment by the concerned Executive Engineer will be withheld. Data generation is the essence of this contract.</p> <p>In respect of completed wells, the 100% payment will be released for the executed work. The necessary deductions towards non achievement of milestone, income tax, labour cess etc will be applicable on this payment.</p> <p>In case of wells where compressor development has been completed but, water sample analysis and BDR are not completed due to genuine reasons duly accepted by Regional Director and all other items of</p>

			<p>BOQ as ordered by employer have been completed, the well will be treated as partially completed.</p> <p>In respect of partially completed wells, only 70% payment against executed work up to well Development shall be made subject to submission of all data pertaining to work executed. The necessary deductions towards non achievement of milestone, income tax, labour cess etc will be applicable on this payment.</p> <p>The balance payment of 30% after necessary deductions will be released after completion of remaining work like pumping test, water sample analysis and submission of BDR and their acceptance by the Regional Director, NWHR, Jammu, for Division VIII, Jammu for the UT of Laddakh.</p> <p><u>Release of Final Payment of PZ part</u></p> <p>After final quantities of various items of BOQ of PZ are executed, a vitiation statement shall be prepared by the concerned Executive Engineer and submitted for approval of Chairman CGWB clearly bringing out comparison of total amount of various tenderers who participated in the tender “as per finally executed quantities multiplied by itemise rates quoted by the tenderers in respect of various items of BOQ“. If any vitiation in contract is found then the difference of amount between lowest cost as per vitiation statement and the total value of actual BOQ arrived based on item wise contract price, will be recovered from the final bill. Final payment along with Retention Money/Security Deposit of complete project shall only be released by the concerned Executive Engineer with prior approval of vitiation statement by Chairman CGWB.</p> <p>Note: The actual Tax (GST) as applicable will be reimbursed against the valid invoice only after producing the following proof of tax amount paid to Government (i) A copy of GSTR-1, (ii) A copy of GSTR- 3B, (iii) CA certificate indicating details of invoices against which the payment under GSTR-3B has been made and any other relevant document.</p>
10.	6.5	Advance	Advance as per extant rule in GFR and procurement manual will be admissible.

11	8.0	Operation Contract of	<p>Milestone/ Deliverables/Period of completion The total Time period for the completion of this Package shall be 300 days as below:</p> <p>(A) For Construction of the Piezometer Wells Milestone is as follows: Total number of wells should be completed on or before 300 days from the date of issue of Work Order by the The Supertending Engineer, Central Ground Water Board, Bhujal Bhawan, NH-IV, Faridabad, 121001. The well will be treated as complete only when all the ordered items of BOQ including pumping tests if specified in the BOQ (i.e. items as ordered by CGWB representative as per site condition for each well) are complete including submission of item wise data and BDR. Against each milestone, the cumulative progress of works in percentage (i.e. number of wells in percentage) to be achieved and amount to be withheld (in percentage) in case of non -achievement against each milestone are furnished in the table given below. In case the bidder accelerate the cumulative progress of work and completes the work within stipulated period, the withheld amount if any will be released without any interest</p> <p>In case of wells where pumping test (if specified in BOQ), water sample analysis and BDR are not completed due to genuine reasons duly accepted by Regional Director and all other items of BOQ including well development as ordered by employer have been completed, the well will be treated as partially completed. The partially completed wells will not be counted for milestone i.e, for cumulative progress of work. Only completed wells in all respect will be counted for milestone.</p> <p>In case the contractor does not achieve a particular milestone mentioned the percentage/ amount shown against that milestone shall be withheld, to be adjusted against the compensation levied at the final grant of extension of time. Withholding of this amount on failure to achieve a milestone, shall be without any notice to the contractor. However, if the contractor catches up with the progress of work on the subsequent milestone(s), the withheld amount shall be released. In case the contractor fails to make up for the delay in the subsequent milestone(s), percentage/ amount mentioned</p>
----	-----	-----------------------	---

			<p>against each milestone missed subsequently also shall be withheld. No interest, whatsoever, shall be payable on such withheld amount.</p> <table border="1"> <thead> <tr> <th>Milestone</th> <th>Time since award of work (in days)</th> <th>Cumulative progress of works(i.e. number of wells) to be completed</th> <th>Amount to be withheld in case of non-achievement of milestone</th> </tr> </thead> <tbody> <tr> <td>1</td> <td>60</td> <td>20%</td> <td rowspan="5">10% of the running bill amount passed for payment by the concerned Executive Engineer.</td> </tr> <tr> <td>2</td> <td>120</td> <td>40%</td> </tr> <tr> <td>3</td> <td>180</td> <td>60%</td> </tr> <tr> <td>4</td> <td>240</td> <td>80%</td> </tr> <tr> <td>5</td> <td>300</td> <td>100%</td> </tr> </tbody> </table> <p>In case, the contractor completes the Work before the milestone deadline, then he shall be paid by the employer upon submission of bills irrespective of the milestone deadline.</p>	Milestone	Time since award of work (in days)	Cumulative progress of works(i.e. number of wells) to be completed	Amount to be withheld in case of non-achievement of milestone	1	60	20%	10% of the running bill amount passed for payment by the concerned Executive Engineer.	2	120	40%	3	180	60%	4	240	80%	5	300	100%
Milestone	Time since award of work (in days)	Cumulative progress of works(i.e. number of wells) to be completed	Amount to be withheld in case of non-achievement of milestone																				
1	60	20%	10% of the running bill amount passed for payment by the concerned Executive Engineer.																				
2	120	40%																					
3	180	60%																					
4	240	80%																					
5	300	100%																					
12.	8.2	Compensation for Delay	Liquidated damage as per G.C.C 8.2 shall be applicable.																				
13.	9.1	Dispute Resolution Board	<p>The Dispute Resolution Board shall comprise</p> <ol style="list-style-type: none"> i) The concerned Member, CGWB under whose jurisdiction the work is being executed ii) The FAO, CGWB iii) The Regional Director, CGWB of the concerned region/s . iv) The Superintending Engineer, CGWB under concerned Member 																				
14.	9.2	Arbitration	The Chairman, CGWB shall appoint the Arbitrator. In case of any dispute, it will be settled within the jurisdiction of Faridabad, Haryana.																				
15.	11	Laws Governing the Contract:	In addition to existing conditions in G.C.C, the contractor shall assist the employer throughout continuation of contract in respect of all matters arising out of contract, serve all notices and obtain all consents, approval and permission on behalf of employer required to be taken under any regulation and by laws of the local or other authority which shall be applicable to work.																				

SECTION- V

SCOPE OF WORK AND TECHNICAL SPECIFICATIONS

SECTION-V – PART A- SOFT ROCK

SCOPE OF WORK AND TECHNICAL SPECIFICATIONS

1	General <p>The locations for construction of wells provided in the section- VII are tentative. The contractor on award of work shall confirm the locations from concerned Regional Director, CGWB before deputing manpower and machinery for undertaking the work. In case work could not be carried out at a particular site due to a genuine reason like non approachability, land dispute, etc. alternate site will be provided.</p> <p>The Contractor shall have to furnish in writing to the concerned Regional Director & Executive Engineer, CGWB, a programme of drilling of wells within a week of handing over the pin pointed sites to the Contractor.</p> <p>The location/sites furnished are tentative. The Employer reserves the right to modify or change the location as well as the depth of construction as per the local prevailing conditions and no additional cost will be paid in this regard.</p> <p>For the purpose of drilling, approach road, water for drilling, crew, camp and other infrastructure, preparation of the site and placing the rig etc, are to be arranged by the drilling contractor at his own cost. At each site, a tent with furniture should be provided to facilitate the CGWB representative to discharge his duties.</p> <p>No payment shall be made against shifting of rig unit with accessories for construction of Piezometers</p> <p>Technical problems during drilling like jamming of drill string, damages to drilling tool, stoppage of work due to unforeseen reasons etc would be the responsibility of the drilling contractor and no compensation of any kind would be paid by the department. In case the well could not be completed and had to be abandoned due to contractor's fault, no payment will be made for that well. In case the well is abandoned due to geological condition such as poor discharge, inadequate depth of good quality water bearing formation, etc, duly certified by representative of CGWB and on approval of Regional Director, payment for executed works will be made. The decision of Regional Director/Executive Engineer will be binding on contractors in deciding whether the well is abandoned due to contractor's fault or due to hydro geological conditions.</p> <p>Drilling Fluid (Bentonite Mud fluid) required for drilling and for efficient removal of cuttings to reach the targeted depth and saving borehole from collapsing will be the responsibility of the contractor.</p>
2	Scope of Work and Overview
2.1	Scope of Work <p>The scope involves drilling of pilot hole, collection of samples for preparation of lithology,,</p>

	<p>electrical logging(SP, Resistivity & Natural Gamma), preparation of composite log, design of well assembly, enlargement of hole size by reaming, lowering of well assembly, gravel shrouding, cement sealing, clay packing, development, pumping test and data analysis, ,collection of water samples for chemical analysis, chemical analysis of water sample and preparation of Basic Data Report .</p> <p>The details of all the activities to be carried out by the contractor including methodology to be adopted and reporting formats are discussed in this section Sl. No 3.0 to 17.0.</p> <p>The contractor should deploy minimum _____ Nos of Rig unit attached with pump unit [No of rig unit to be calculated based on formula given below:</p> <p>$R = (W \times D) / T$ Where, R is the minimum number of Rig unit required W is the total No of wells D is the average number of days required to complete one well (i.e. D= 3 in case of 200m well in Hard rock and D = 20 in case of 300m well in soft rock) And T is the scheduled time period for completion of the project in days]</p>
<p>3.</p>	<p>Construction of Piezometer Wells</p> <p>The number of Peizometer wells to be constructed is given in Section VI.Tentative locations of Peizometer wells is given in section VII. The employer reserves the right to change the location in case of non availability of site clearance or any other reasons and no additional cost will be paid for change in locations.</p> <p>For Piezometer drilling of pilot hole of 216 mm(8 ½”) by RR/ Drag bit using Bentonite drilling fluid shall be carried out. The targeted depth of pilot hole is as per BOQ , however it may vary from about 100 m to 305m or as specified in the BOQ depending upon geology.</p> <p>Formation strata samples should be collected after proper washing adopting standard procedure for sample collection for every 3 m or in the event of change in formation.</p> <p>Electrical logging and natural gamma logging as specified in BOQ shall be carried out upto bottom of pilot hole. Logging Report alongwith Zone wise water quality shall be submitted.In case the logging could not be completed to desired depth in 8 ½” pilot hole after repeated attempts, logging in larger dia hole may be allowed by site hydrogeologist and no additional payment will be made for enlargement of hole for logging purpose and for additional attempts of logging.</p> <p>The depth of blank pipe and slotted pipe with bail plug (well assembly) will be decided by the employer’s site Hydro Geologist/representative of Regional Director, according to the formation encountered during drilling. The depth of well assembly may vary from 100 m to 300m or as per BOQ</p> <p>The bill of quantity should contain only final reamed size of the Piezometer wells and its depth and hence rate should be quoted for final reamed size and its depth only i.e. the final reamed</p>

	<p>rate deemed to cover the intermediate reaming sizes. The reaming with intermediate sizes should not be included in the bill of quantity.</p> <p>As per recommendation of assembly chart, casing pipe/slotted pipe as mentioned in this section Sl. No 5 should be lowered. After assembly lowering, back washing should be carried out.</p> <p>Gravel shrouding should be carried out as mentioned in this section Sl. No 7.</p> <p>Cement Sealing and Clay packing shall be provided as mentioned in this section Sl.No 8.</p> <p>Well development should be carried out as mentioned in this section Sl. No 10.</p> <p>Water samples as specified in BOQ should be collected during well development from Piezometer in good quality polypropylene bottles using standard procedures for Basic parameter analysis and for heavy metals as per direction of representative of CGWB as per the BOQ Document.</p> <p>Analysis of sample as per BOQ shall be carried out by Contractor from NABL accredited lab and shall be submitted to the Regional Director, CGWB, Concerned Region. One set of sample (Basic and heavy metal) from Piezometer shall be submitted to the Regional Director, CGWB, Concerned Region ..</p>
<p>4</p>	<p>Methodology / Approach</p>
<p>4.1</p>	<p>Process /Methodology Involved In Construction Of Wells In Soft Rock Up To 300 M Depth</p> <p>Piezometer Wells</p> <ul style="list-style-type: none"> (i) Site selection and pinpointing of site (ii) Shifting of Rig (iii) Site preparation (iv) Pilot hole drilling [using 216mm (8½") diameter RR Bit/ Drag Bit] as per BOQ (v) Sample collection & preparation of litholog (vi) Bore hole logging (Resistivity, SP, Natural Gamma) (vii) Preparation of E log Report including Zone wise quality (viii) Preparation of Composite log using data of (v) & (vi) above (ix) Designing of Well assembly (x) Reaming of Bore hole (by using appropriate size of RR bits based on recommended well assembly size, giving a margin for minimum 100mm thickness for gravel packing) as per BOQ (xi) Lowering of well assembly (xii) Back washing, shrouding of gravel and Clay packing (cement sealing, if required). Cement sealing should be done by tremie pipe. Adequate rest shall be provided after cement sealing. Clay balls should be used clay packing.

	<ul style="list-style-type: none"> (xiii) Verticality test of well(if required) (xiv) Zone wise Development of well by air compressor, overpump or by any other means till the water is clear and sand free (xv) Pumping Test if specified in BOQ <ul style="list-style-type: none"> a. Water sample collection for analysis of Basic & Heavy metals under guidance of CGWB site Hydrogeologist/ Chemist. (xvi) Construction of platform, well capping and installation of protection box (xvii) Preparation of Basic Data Report & submission (xviii) Clearance of site and bringing it to original natural condition (xix) Handing over of well
4.2	Deleted
5	<p>Well Assembly</p> <ul style="list-style-type: none"> (i) M.S Casing pipes used for well assembly should confirm to the specification given below. <ul style="list-style-type: none"> (a) BIS marked steel tubes plain ended with bevelled edges on both ends, for water wells of type ERW conforming to Table No 3 of IS: 4270/2001 (third revision). The steel for the ERW casing pipes shall be of Make Tata, Jindal, SAIL, Essar and test certificate of material from Tata/Jindal/SAIL/Essar shall mandatorily be submitted to the Engineer-Incharge at the time of Inspection. (ii) <i>LCG V-wire screen pipe with slot opening as mentioned in BOQ should confirm to latest version of IS:8110-2000. Test certificate of OEM mandatorily be submitted to the concerned Executive Engineer at the time of Inspection. The material should be inspected and approved by the concerned Executive Engineer or his representative before lowering. Random lab test shall be carried out by the EE or his rep. for Diameter of Screen, Slot Size, Collapse Strength, Tensile Strength, Weld joint strength, ID, OD and Thickness. (Cost of test shall be borne by the Contractor).</i> (iii) A length of 0.50 m of casing pipe should be left above the ground level. (iv) Well cap should be securely sealed to the pipe after tube well is checked by the Engineer-In-Charge.
6	<p>Data Collection</p> <p>Drilling contractor will</p> <ul style="list-style-type: none"> (i) Maintain a drill time log for every 3 m for wells drilled or in the event of change in formation in soft rock formations. (ii) Collect formation samples of minimum 500g mass at an interval of 3m or change of formation during drilling and properly pack in polythene bags and label with date/ depth/ location. (iii) Carry out geophysical logging (SP, Resistivity & Natural Gamma) (iv) Measure discharge over 90° V notch plate during development of well. (v) Collect 1 litre water sample after development is complete and during test for wells drilled in soft rock formations in good quality polypropylene bottles using standard procedures for basic analysis and heavy metals. Two sample (one for basic parameters and one for heavy metals) or as specified in BOQ <p>Necessary arrangements are to be made for verification by Engineer-In-Charge/ CGWB site Hydrogeologist for checking of depth of borehole, length of casing, static water level, discharge</p>

	and any other requirement as shall be felt necessary from time to time. A guest tent should be pitched at the site during drilling/ testing and provided with table and chairs for the Site Hydrogeologist/ Engineer-In-Charge.
7	<p>Gravel Packing of Tubewell</p> <p>After the well assembly has been placed in position, the Pea gravel as per specification mentioned in BOQ has to be shrouded in the annular space between the well assembly pipe and the borehole by adopting reverse fluid circulation method upto the depth as mentioned in assembly chart recommendation. The gravel should be of rounded to sub-rounded shape and shall be supplied by the Contractor. Before shrouding, the pea gravel must be got inspected and approved by CGWB site representative. Sufficient care should be taken so that gravel packing is proper and no bridging takes place during gravel shrouding. If necessary, in case of bridging of gravel, air compressor of appropriate capacity should be used for proper gravel shrouding as per instruction of employer's site representative for which no additional cost will be paid. After gravel packing, sounding should be carried out to ascertain the correct depth of gravel packing. As a cross check, the theoretical annular volume of gravel packing and volume of actual gravel consumed should be compared to ascertain that gravel shrouding is without bridging. In case of EW the gravel packing shall be measured in meters from the bottom of Reamed depth or from Assembly depth+ 5 m, whichever ever is less. In case of OW, gravel pack shall be measured from bottom depth of hole or from Assembly depth+ 5 m, whichever ever is less. If gravel packing is not carried out properly, no payment will be made till rectification.</p>
8	<p>Cement Sealing and clay packing of Tube Well:</p> <p>After Gravel shrouding is done cement sealing (if required) shall be done using tremie pipe. Cement sealing of 5 m thickness shall be provided. Before cement sealing 1 m thick clay shall be provided above gravel. Adequate rest (minimum 10 hrs) shall be provided after cement sealing.</p> <p>Annular space between borehole and pipe above cement seal (if provided) shall be filled with clay balls. If cement sealing is not provided clay packing shall be provided above gravels.</p>
9	<p>Verticality Test</p> <p>The vertical test shall be carried out in wells where pump/eduction pipe cannot be lowered smoothly to the desired depth and the contractor shall carry out the vertical test at his cost as per the decision of the Employer side representative. The well assembly shall be placed vertically inside the borehole. Verticality test as per IS: 2800 (Part 2) -1979 must be arranged by the Contractor with standard equipment at his cost. In case of deviation beyond the permissible limit, the well will be treated as vertically out. The acceptance of suitability of the well will be purely at the discretion of CGWB. The well will not be accepted in case pump could not be lowered to desired depth due to non-verticality of well and no payment will be made.</p>

10	<p>Well Development</p> <p>Zone wise development of wells shall be carried out by air compressor of appropriate capacity i.e. minimum 1723.69 KPa(250 Psi) and minimum 21.23 cubic meter per minute (750 cfm) immediately after construction within 5 days of construction of well. Subsequently well should be developed by over pumping by VT/Submersible pump or by any other means till the water is free from mud and fine sand. In case development is not carried out in time resulting in poor yield or in case the well is not properly developed, no payment will be made till recification is carried out.</p>
11	<p>Construction of Platform and installation of Well Cap, Protection Box and Display BOARD</p> <p>After completion of well in all aspects, the well should be provided with well cap using MS plate of minimum thickness 6mm and protection box made of minimum 3.00 mm GI sheets with Brass lock (7 lever) with all common keys (One Key for multiple locks) preferably Make: Godrej/Harrison/Link with three individual keys for each well.</p> <p>A concrete platform using concrete mix of 1:2:4 should be provided around the well pipe welded with minimum 6 No's of 38mm (1 ½") L angle as per the drawing specification given in the tender. Schematic diagram of well is given in section IX.</p> <p>A Display Board as per drawing in the section IX with details of wells should be installed near the well. On completion of well, the site around the well should be brought to previous natural condition</p>
12	<p>Successful and Unsuccessful Well</p> <p>Success of well will be decided by the Representative of Regional Director. In case of non-availability of minimum thickness of aquifer capable of yielding expected discharge, the bore hole may be abandoned and payment based on actual work carried out will be made at quoted rates. The well abandonment committee will be constituted by respective Regional Director and will consist of two officers of hydrogeological discipline and one officer of engineering discipline to decide upon the measurement of unsuccessful well. If the well is abandoned due to the fault of the contractor or due to the limitations of the machinery, borehole fishing etc, no payment shall be made.</p>
13	<p>Mode of Measurement</p> <p>The Contractor shall be paid on actual Computerised Measurement Books (CMB) of finished work on the basis of quoted rates. The Contractor shall be eligible for payment of full length drilling of pilot hole irrespective of the design of tube well assembly provided the more drilling necessitated in search of a suitable aquifer and as per the advice of Engineer- In-Charge.</p>
14	<p>The Surrounding Area After Well Completion</p> <p>The area surrounding the well site has to be levelled, pits to be filled and the area to be restored to the original condition i.e. as before start of drilling operation.</p>
15	<p>Handing Over of Tubewell</p> <p>The well must be properly handed over to the CGWB along with hard and soft copy of BDR in triplicate. The wells will be treated as completed and handed over only on submission of Basic Data report along with all data, analysis, Graph sheet etc (Hard copy in triplicate & soft copy)</p>

	duly accepted by the Regional Director, CGWB, Concerned Region. The copy of the accepted BDR and related document, if any, is to be submitted to concerned Executive Engineer for payment purpose.	
16	Monitoring and Measurement of Work	
16.1	The monitoring and measurement of different activities for PIEZOMETER drilling shall be as specified in below table	
	S. No.	Parameter
	1)	Location of site
	2)	a)Depth/ Diameter of pilot hole in Piezometer
		b) Depth of reaming
	3)	Inspection of assembly pipes, screen pipes, gravel etc. as per specification
	4)	Litholog/ Electrical log/ Composite log/ Well Design
	5)	Installation of well assembly and gravel shrouding
	6)	Development of well
	7)	Testing of well
	8)	Well capping/ construction of platform and installation of protection box
	PS: The contractor will report to the Engineer-In-Charge via e-mail/phone the daily progress at each site and submit status report on weekly basis to Executive Engineer.	

18	<p>Preparation and Submission of BDR</p> <p>The contractor is required to prepare the basic data report (BDR) for the wells as per the format provided in Section-VIII. The BDR along with litholog, logging data, test data, graph sheet, analysis report shall be submitted to CGWB in soft as well as hard copy (in triplicate). In site where more than one well is constructed, one BDR should be prepared for all the wells constructed in the site and the litholog, well diagram, time log, static water level etc for EW and OW should be furnished separately in the BDR.</p>
19	<p>Specification and Drawings</p> <p>The specifications for drilling and construction of wells shall be as specified in the bill of quantities. The drawings for Well cap, Protection Box, Cement concrete platform, Display Board and Display Board platform is provided in Section- IX.</p>

SECTION-V – PART B- HARD ROCK/Bouldery Formation

SCOPE OF WORK AND TECHNICAL SPECIFICATIONS

1 General

The locations for construction of wells provided in the section- VII are tentative. The contractor on award of work shall confirm the locations from concerned Regional Director, CGWB before deputing manpower and machinery for undertaking the work. In case work could not be carried out at a particular site due to a genuine reason like non approachability, land dispute, etc. alternate site will be provided.

The Contractor shall have to furnish in writing to the concerned Regional Director & Executive Engineer, CGWB, a programme of drilling of wells within a week of handing over the pin pointed sites to the Contractor.

The location/sites furnished are tentative. The Employer reserves the right to modify or change the location as well as the depth of construction as per the local prevailing conditions and no additional cost will be paid in this regard.

For the purpose of drilling approach road, water for drilling, crew, camp and other infrastructure, preparation of the site and placing the rig at the site etc., are to be arranged by the drilling contractor at his own cost. At each site, a tent with furniture should be provided to facilitate the CGWB representative to discharge his duties

Technical problems during drilling like jamming of drill string, damages to drilling tool, stoppage of work due to unforeseen reasons etc would be the responsibility of the drilling contractor and no compensation of any kind would be paid by the department. In case the well could not be completed and had to be abandoned due to contractor's fault, no payment will be made for that well. In case the well is abandoned due to geological condition such as poor discharge, inadequate depth of good quality water bearing formation, etc, duly certified by representative of CGWB and on approval of Regional Director, payment for executed works will be made. The decision of Regional Director/Executive Engineer will be binding on contractors in deciding whether the well is abandoned due to contractor's fault or due to hydro geological conditions

2 Scope of Work and Overview

2.1 Scope of Work

The scope involves drilling and casing of overburden, drilling in hard rock up to the targeted depth, identification of depth of each fracture, assessment of yield after encountering of each fracture, development and testing of Piezometers Wells if specified in BOQ , collection of lithlog samples and water samples, chemical analysis of water samples, preparation of lithology and preparation of Basic Data report.

The contractor shall be required to carry out drilling and construction of Piezometer Wells as per tender, development by air compressor and conducting preliminary yield of wells ,

slug test and data analysis if specified in BOQ, preparation of basic data reports along with site location map, and submission to CGWB in prescribed format (section-VIII &IX) in triplicate along with well diagram in details of reaming diameter, well size and depth, cement sealing depth if any, clay packing depth etc.

The details of all the activities to be carried out by the contractor including methodology to be adopted and reporting formats are discussed in following section 3.0 to 17.0. Tentative list of locations has been provided in section-VI.

The contractor should deploy minimum _____ Nos of Rig unit attached with pump unit
[No of rig unit to be calculated based on formula given below:

$$R = (W \times D) / T$$

Where,

R is the minimum number of Rig unit required

W is the total No of wells

D is the average number of days required to complete one well (i.e. D= 3 in case of 200m well in Hard rock and D = 20 in case of 300m well in soft rock)

And T is the scheduled time period for completion of the project in days]

3. Construction of Piezometer Wells

It is proposed to construct Piezometer well for 200m or depth as specified in BOQ.).

Tentative locations of Piezometer wells are given in **section VII**. The employer reserves the right to change the location in case of non availability of site clearance or any other reasons and no additional cost will be paid for change in locations

The number of Piezometer well to be constructed shown in Section- VI.

Water sample should be collected in 1litre HDPE bottles using standard procedures as specified in the BOQ. BDR along with litholog, logging data and report, test data and report etc. along with well diagram incorporating all details should be submitted. On completion of well, the site should be brought to the previous natural condition.

The well should be provided with well cap using MS plate of minimum thickness 6mm and protection box made of **3.00 mm** GI sheets with Brass lock (7 lever) with all common keys (One Key for multiple locks) preferably Make: Godrej/Harrison/Link with three individual keys for each well. A concrete platform (using concrete mix of 1:2:4) as per drawing should be provided around the well housing pipe as per the specification given in the tender.

The Engineer in charge will decide the actual casing length at site based on overburden encountered. Lithologs samples should be collected after proper washing adopting standard procedure for sample collection for every 1m or in the event of change in formation.

Also Preliminary Yield Test (PYT) should be conducted if specified in the BOQ or if required as per instruction of site officer on encountering each fracture with substantial discharge. For conducting PYT, 75mm diameter M.S Pipe (Eduction pipe) up to 1m

above bottom level of drilling and 25mm dia airline should be lowered inside education pipe up to approximately 1m above bottom level of education pipe or the air line should be placed in education pipe so that the discharge is optimum. 20mm MS/ PVC pipe should be lowered for measuring water level. Slug test has to be conducted on need based or if specified in BOQ, on instruction of site geologist. The proper jigs and fixture or anchoring of pipes during the test... Water sample should be collected during pumping test and during drilling in 1 litre HDPE bottles and handed over to the Regional Director with receipt. The nomenclature should be made on the bottle to identify the site where the water is collected. BDR along with litho log, logging data and report, test data and report, water sample analysis report etc should be submitted. Also well diagram with details such as overburden drilling diameter and its depth, casing pipe lowered and its diameter and depth, naked bore diameter, depth at which fractures encountered, static water level, V notch discharge on encountering each fractures and depth, its size and depth clay packing, cement sealing if required, concrete platform etc should be submitted. The well should be provided with well cap using M.S plate of minimum thickness 6mm and protection box as per drawing. A concrete platform should be provided around the well housing pipe welded with minimum 6 Nos. of anchoring plate as per the drawing specification given in the tender. Schematic diagram of well is given in section-IX. On completion of well, the site around the well should be brought to previous natural condition.

4 Methodology / Approach

4.1 Process/ Methodology Involved In Construction Of Wells In Bouldery Formation Up To 300/200/100 M Depth

Piezometer Wells

- (i) Site selection and pinpointing of site
- (ii) Shifting of Rig
- (iii) Site preparation
- (iv) Telescopic Drilling using DTH-Odex method up to targeted depth
- (v) Borehole drilling not more than 216mm (8½") diameter.
- (vi) Sample collection & preparation of litholog.
- (vii) Designing of Well assembly in consultation with CGWB
- (viii) Lowering of well assembly
- (ix) Shrouding of gravel. Pulling out Casing pipe simultaneously.
- (x) Verticality test of well (if required)
- (xi) Zone wise Development of well by air compressor/ PYT/ Slug test to be conducted if and as specified in BOQ
- (xii) Water sample collection for analysis of Basic & Heavy metals under guidance of CGWB site Hydrogeologist/ Chemist if and as specified in BOQ.
- (xiii) Construction of platform, well capping and installation of protection box if and as specified in BOQ.
- (xiv) Preparation of Basic Data Report & submission if and as specified in BOQ
- (xv) Clearance of site and bringing it to original natural condition
- (xvi) Handing over of well

5 Casing

- (i) M.S Casing pipes used for well assembly should confirm to the specification given below.
 - (a) BIS marked steel tubes plain ended with bevelled edges on both ends, for water wells of type ERW conforming to Table No 3 of IS: 4270/2001 (third revision). The steel for the ERW casing pipes shall be of Make Tata, Jindal, SAIL, Essar and test certificate of material from Tata/Jindal/SAIL/Essar shall mandatorily be submitted to the Engineer-Incharge at the time of Inspection.
- (ii) *LCG V-wire screen pipe with slot opening as mentioned in BOQ should confirm to latest version of IS:8110-2000. Test certificate of OEM mandatorily be submitted to the concerned Executive Engineer at the time of Inspection. The material should be inspected and approved by the concerned Executive Engineer or his representative before lowering. Random lab test shall be carried out by the EE or his rep. for Diameter of Screen, Slot Size, Collapse Strength, Tensile Strength, Weld joint strength, ID, OD and Thickness. (Cost of test shall be borne by the Contractor).*
- (iii) M.S Casing pipes as specified in above should confirm to the specification given below.
- (iv) BIS marked steel tubes plain ended for water wells of type ERW conforming to Table No 3 of IS:4270/2001 (third revision).
- (v) A length of 0.50 m of casing pipe should be left above the ground level.
- (vi) MS Casing pipe should be installed perfectly vertical on the consolidated rock basement in such a manner that there should not be leakage of air during drilling. The annular space between the casing and the borehole wall should be grouted with cement slurry to avoid entry of local foreign material in the borehole in consolidated formations.
- (vii) Well cap should be securely sealed to the pipe after bore hole is checked by the Engineer-In-Charge. The well cap should be fabricated as per the provided specifications by CGWB.

6 Well Development

In respect of borehole drilled in hard rock/ Bouldery Formations formations, well should be washed/ developed using compressor thoroughly after completion of the drilling operation till clear water comes.

7 Construction of Platform, Well Cap, Protection Box and Display BOARD

After the completion of well in all respects described above, the contractor shall fabricate and install well cap using MS plate of minimum thickness 6mm, make platform around well, and install Display Board and Protection Box as described in the Drawings in section-IX

8 Data Collection

Drilling contractor will

- i. Maintain a drill time log for every meter of drilling for wells drilled in hard rock formation.
- ii. Measure discharge over 90° V notch plate during drilling on every increase/decrease of yield at various depths for wells drilled in hard rock formations.
- iii. Collect formation samples of minimum 500 g mass at an interval of 3m or change of formation during drilling and properly pack in polythene bags and label with date/ depth/ location.
- iv. Collect 1 litre water sample for every water-bearing zone encountered for wells drilled in hard rock formations.

Necessary arrangements are to be made for verification by Engineer-In-Charge for checking of depth of borehole, length of casing, static water level, discharge and any other requirement as shall be felt necessary from time to time. A guest tent should be pitched at the site during drilling/ testing and provided with table and chairs for the Engineer-In-Charge.

9 Verticality Test

If required, the vertical test shall be carried out in wells where pump/eduction pipe cannot be lowered smoothly to the desired depth and the contractor shall carry out the vertical test at his cost as per the decision of the Employer side representative. The well assembly shall be placed vertically inside the borehole. Verticality test as per IS: 2800 (Part 2) -1979 must be arranged by the Contractor with standard equipment at his cost. In case of deviation beyond the permissible limit, the well will be treated as vertically out. The acceptance of suitability of the well will be purely at the discretion of CGWB. The well will not be accepted in case pump could not be lowered to desired depth due to non-verticality of well and no payment will be made.

10 Successful and Unsuccessful Well

Success of well will be decided by the Employer authorized officer. In case of non-availability of minimum thickness of aquifer capable of yielding expected discharge, the bore hole may be abandoned and payment based on actual work carried out will be made at quoted rates. The tube well abandonment committee will be constituted by respective Regional Director and will consist of two officers of hydrogeological discipline and one officer of engineering discipline to decide upon the measurement of unsuccessful well. If the well is abandoned due to the fault of the contractor or due to the limitations of the machinery, borehole fishing etc, **no payment shall be made.**

11 Submission of reports in the prescribed formats

The following reports are required to be submitted by the contractor in the format prescribed in relevant Annexure in hard as well as soft copies:

- (i) Litholog
- (ii) PYT and Slug test (if specified in BOQ) Data as per proforma
- (iii) Logging data as per proforma and analysis
- (iv) Water sample chemical analysis report.
- (v) Consolidated statement of test (As per proforma in section VIII)
- (vi) BDR as per proforma enclosed in section VIII

12 Preliminary yield Test (PYT)) if specified in BoQ

The contractor has to carry out the PYT as per instruction of employer site representative in order to determine aquifer parameter (Transmissivity, Specific capacity)

12.1 Methodology/Approach

Transmissivity may be determined by conducting Preliminary Yield Test in wellshaving discharge around 1 lps to 1.5 lps or based on hydrogeological condition, as per the instruction of employer site representative.

Method/Procedure:

- (i) For conducting PYT, 75mm dia or higher dia GI/ MS/ (Eductor pipe) upto 1m above bottom level of drilling and 25mm dia airline should be lowered inside eduction pipe up to 1m above bottom level of eductor pipe or the air line should be placed in such a way that the discharge of water is optimum. 20 mm GI/ MS/ PVC pipe should be lowered for measuring water level and using water level sounders, the water level should be measured.
- (ii) Pre pumping water level is to be measured in the pumping well.
- (iii) The well is to be pumped at a constant discharge for long duration (100 min) and water level during recuperation (recovery) should be are measured periodically (Section-VIII). The discharge should be measured using 90° V Notch
- (iv) Recovery water level is to be recorded as per data sheet (Section-VIII) after stopping the pump until the pumped water level reaches static water level or 90% of the static water level.

The data recorded shall be analysed by using Jacob straight line method.

13 Slug Test (if specified in BoQ)

The contractor shall conduct slug test in piezometers (if specified in BOQ) as and when required by the employer.

13.1 Methodology/ Approach

Slug tests is to be conducted in wells as per the decision of employer, where conventional aquifer performance tests cannot be conducted due to constraints of yield. In this method, a known volume or Slug of water (maximum 20 litre) is instantaneously injected into the well and the water level is measured at periodic intervals till the pre-injection water level returns to the pre-injection level or for a pre-determined period, whichever is less.

Procedure for conducting slug test:

- (i) Collect and record all available information (depth, diameter, yield, aquifer type, lithology etc.) about the tube well / bore well to be tested
- (ii) Measure the static water level before the injection of slug.
- (iii) Inject a known volume (slug) of water (not more than 20 litres) into the bore well/tube well.
- (iv) Measure the water level at closely spaced intervals (once every minute up to 10 minutes, once every 2 minutes up to 20 minutes and then on once every 5 minutes till completion).
- (v) Continue recording depth/time measurements until the water level returns to pre-injection level or a sufficient number of readings have been made to clearly show a trend on a plot of water level recovery versus the logarithm of time.
- (vi) Estimate the value of change in head (H_0) in response to injection of slug (H_0). Compute also the change in water levels (H) for each subsequent measurement.
- (vii) Compute the values of H/H_0 for each measurement.

Analysis of Data

Field data generated need to be analysed using standard methods

- (i) For Unconfined aquifer - Hvorslev method (1951)/Bouwer and Rice method (1976).
- (ii) For confined aquifers - Cooper et al (1967) method

13.2 Technical Specifications

- (i) Slug test is to be conducted in Piezometers (only if specified in BOQ)
- (ii) Conducting test with slug injection (20 litres)
- (iii) Slug injected should be of potable water quality.
- (iv) Recording water level data in periodic time steps (minute recording upto 10 min, 2 minute recordings upto 20 minutes and then on 5 minute recordings till completion)

Analysis of data generated using following method for unconfined aquifer by

- (i) Hvorslev method(1951) and
- (ii) Bouwer and Rice method (1976)

For Confined aquifer by - Cooper et al (1967)

Submission of report in prescribed format (Hard and Soft copy) containing

- (i) Site location details – (Section-VI)
- (ii) raw data sheet - (Section-VIII)
- (iii) Processed graph sheet
- (iv) Calculation details and results
- (v) Consolidated statement of slug test (Section-VIII)

14 Mode of Measurement

The Contractor shall be paid on actual Computerised Measurement Books (CMB) of finished work on the basis of quoted rates. The Contractor shall be eligible for payment of full length drilling of bore hole.

15 The Surrounding Area After Well Completion

The area surrounding the well site has to be levelled, pits to be filled and the area to be restored to the original condition i.e. as before start of drilling operation.

16 Handing Over of well

The tube/bore well must be properly handed over to the CGWB along with hard and soft copy of BDR in triplicate. The wells will be treated as completed and handed over only on submission of Basic Data report along with all data, analysis, Graph sheet etc (Hard copy in triplicate & soft copy) duly accepted by the concerned Regional Director, CGWB. The copy of the accepted BDR and related document, if any, is to be submitted to Executive Engineer for payment purpose

17 Monitoring and Measurement of Work :

17.1 The monitoring and measurement of different activities for PIEZOMETER drilling shall be as specified in below table

S. No.	Parameter	Monitoring Mechanism / Measurement Criteria
1)	Location of site	Site selection report(s) duly signed by the representatives of contractor, state government and regional office CGWB.
2)	Depth/ Diameter of pilot hole	Sounding should be carried out in the presence of the Engineer-In-Charge. In wells wherever logging is conducted, the log depth will be taken as pilot depth in case of variation between pilot hole depth and logging depth for payment purpose.
3)	Litholog/ Electrical log/ Composite log/Well Design	Verification/ validation by the Regional office.
4)	Development of well	Should be carried out in the presence of Engineer-In-Charge/Regional office site hydro geologist.
5)	Testing of well	PYT and Slug test (if specified in BOQ) wherever applicable should be carried out by the contractor in the presence of Engineer- In-Charge. Analysis and evaluation report to be prepared by the contractor and to be validated by the Regional office
6)	Well capping/ construction of platform and installation of protection box	Physical inspection by the Engineer- In-Charge

PS: The contractor will report to the Engineer-In-Charge via e-mail/phone the daily progress at each site and submit status report on weekly basis to Executive Engineer.

18. Preparation and Submission of BDR

The contractor is required to prepare the basic data report (BDR) for the wells as per the format provided in Section-VIII. The BDR along with data,graph sheet,analysis report for each of the well shall be submitted to CGWB in soft as well as hard copy (in triplicate). In site where more than one well is constructed, one BDR should be prepared for all the Piezometers constructed in the site.The litholog, well diagram, time log, static water leveletc for the Piezometers should be furnished seperately in the BDR.

19 Specification and Drawings

The specifications for drilling and construction of wells shall be as specified in the bill of quantities. The drawings for Display Board and Display Board platform is provided in Section-IX.

SECTION-VI

BILL OF QUANTITIES AND SUMMARY OF PACKAGES

SECTION-VI

BILL OF QUANTITIES AND SUMMARY OF PACKAGES

BILL OF QUANTITIES

FINANCIAL TENDER FORMAT **PACKAGE-8 C** HAS BEEN UPLOADED IN THE BOQ SECTION IN THE E-TENDERING SYSTEM WHICH IS AN INTEGRAL PART OF THIS TENDER DOCUMENT.

SUMMARY OF PACKAGE IN RESPECT OF TENDER FOR CONSTRUCTION OF PIEZOMETERS WELLS

PACKAGE NO	PACKAGE DETAIL	State	<u>BOQ Number</u>	Items	Number of Wells
8 C	(PIEZOMETER)	Laddakh	LD PZ BOQ 1	HR/Bouldery - (100m)	61
TOTAL					61

NOTE common for BOQ

1. While quoting the rates unit cost should be given for all the items. The items of work in BOQ deemed to be cover all kind of works/ items involved in construction of a well as mention in section V, Scope of Work and Technical specification, even though if any specific item is not mentioned in the BOQ. Hence no payment will made for works/ items not mentioned in the BOQ separately.
2. The quantities envisaged in the BOQs are tentative and may vary from site to site the payments will be made on actual basis.
3. No payment will be made for shifting of rig unit and goods required for construction of wells.
4. Unit rates and prices shall be quoted by the bidder in Indian rupee. Amounts must be quoted in full rupees by ignoring fifty paisa and considering more than fifty paisa as rupee one. Bidders have to quote for all items of works of the BOQ. The item for which no rate or price has been entered in, will not be paid for by the Employer when executed and shall be deemed covered by the other rates and prices in the Bill of Quantities.
5. Any modification of GST by the Government the difference will be paid/ recovered to/from the contractor.
6. The contractors are advised to fill the BOQ in financial bid carefully as the system is digital and it is on line. The rate without GST should be entered against the item in BOQ. The payment of GST as applicable will be paid to the contractor on proof of such payment made to the Government.
7. Successful bidder is to comply with the Public Procurement (Preference of Make in India), Order 2017 dated 15.06.2017 as amended upto date, while executing the contract.

BOQ for LADAKH

LD PZ BOQ 1					
BOQ Template for Piezo Meter construction of Ladakh (Bouldery Formatioion 100m)					
Bouldery Formatioion Wells				Type I	
	State(s) Ladakh (AAP 2022-23)				
	Number of PZ wells		61		number
	Depth of pilot hole		100		meter
	Average depth of well construction		70		meter
	Diameter of housing pipe		102		mm
	Length of Housing Pipe		65		meter
	Diameter of intake pipe		100		mm
	Average Length of intake pipe (screen)		5		meter
	Type of screen Stainless steel of SS304 grade		SS304		
	Slot opening		0.75		mm
	Average Development of Piezometer by air compressor		5		hours
	Collection of water samples per site		2		number
	Number of samples per well to be tested for Basic Paramers		1		number
	Number of samples per well to be tested for Heavy metals		1		number
S. No.	Item of work	Unit	Rate/ meterage drilling (Excluding GST)	Total Meterage/total No.	Total Amt. (Excluding GST)
1	Drilling of pilot hole using ODEX for PZ not larger than 216 mm (8 ½”) by button bit including formation sample collection at an interval of 1m or change in formation whichever is earlier , preparation and submission of litholog including installation of ERW casing pipe 65 m of (4" diameter)/well and slotted pipe 5 m of (4" diameter)/well including pulling out of 216mm (8 ½ “) casing pipe.	meter		6100	

1.1	Drilling by DTH method using appropriate sizes of button bits so as to reach targeted depth with diameter of hole not less than 165 mm at 100 m depth and final diameter not less than 152 mm at bottom of holes/150 m depth including sample collection and preparation of litholog	meter		0	
2	Caliper logging to decipher the depth and width of fracture zones, submission of report including logging graph, interpretation of graph, generation of composite log along with video recording	Job		0	
3	Supply and installation of ERW casing pipe conforming to latest version of IS: 4270-2001 of diameter and thickness given below				
3.1	100 mm (4") Nominal Bore, thickness 5.4mm	meter		3965	
4	" Supply and intallation of Stainless Steel 4"(100 mm) dia. x 0.75 mm slot size regular Grade ERW Stainless Steel Cage Type V-wire wound screen as per IS :8110-95 and material specifications as per AISI type 304, Grade SS -304 suitable for water well construction				
4.1	Slot opening 0.75 mm (Stainless Steel SS304 Grade)	meter		305	
5	Supply and shrouding of pea gravel confirming to latest version of IS: 4097-1967				
5.1	Particle size range 2.00 mm to 3.35 mm for 1.0 mm and 0.75 mm slot opening	cu meter		366	
6	Supply and filling up borehole/ annular space between casing pipe and bore hole wall with local clay, if required	job		61	

7	Development by Air Compressor of adequate capacity for minimum 5 hours, over pumping and by other means till discharge water is clear and free of sand including collection of two water samples from PZ well adopting standard procedure in 1 litre HDPE bottle, along with video recordings of compressor hour meter, discharge etc.	job		61	
8	Chemical analysis of water samples for 15 parameters pH, EC, TH, TDS, Ca, Mg, Na, K, CO ₃ , HCO ₃ , SO ₄ , NO ₃ , Cl, F & Fe in NABL accredited labs	job		61	
9	Chemical analysis of water samples for Heavy metals (As, U) in NABL accredited labs and submission of report from NABL lab	job		61	
10	Construction of cement concrete platform of dimension 0.70 X 0.70 X 0.60 m (0.30 m above ground level) using concrete mix of 1:2:4 around the around the Piezometer well welded with minimum 6 Nos of anchoring plate as per drawing	job		61	
11	Supply and fitting of well cap as per drawing with Allen Keys. MS Plate size 5 mm embossed & welded with permanent marking of “CGWB PZ” should be carved with welding on outer surface of casing pipe	job		61	
12	Supply and installation of protection box made of 3 mm GI sheet of Size: 550mm X450mm X530mm along with Brass lock (7 lever hardened) and three keys for each lock as per drawing	job		61	
13	Supply and installation of Display board as per drawing	job		61	

14	Preparation and submission of basic data report per site in triplicate along with data sheets, analysis sheet, chemical analysis report from NABL lab, site location map and approachability with landmarks, photographs and videos of activities of drilling, assembly lowering, gravel measurement and gravel packing, well development using compressor and well water discharge, water sample collection, well discharge with discharge measurement, well site with display board, well cap, protection box for each site, etc. The soft copy as well as hard copy should be submitted. Summary of Piezometer details in xls format (as per proforma given by CGWB) including details of dia and depth of assembly pipe, screen pipe, static water level, gravel packing depth and thickness, Litholog etc. should be also submitted.	job		61	
	Total				
	GST @ 18%				
	Grand Total inclusive of Taxes				
Note:	1. The Pilot hole drilling should be carried out to target depth of 100 m.				
	2. No payment shall be made if well is abandoned without lowering assembly up to the recommended depth citing formation problem				
	3. No payment shall be made if any well is abandoned due to fault of contractor or due to machinery, bore hole fishing, etc citing formation problem except under extraordinary situations like interference/ objection by the Local Government Bodies or public agitation against drilling leading to law and order problems, etc.				
	4. Payment for gravel packing shall be in terms of meterage height measured from the bottom of reamed depth. Also gravel in terms of volume consumed should be cross checked with theoretical volume of gravel packing to ensure there is no bridging during gravel packing. The actual volume of gravel used and theatrical annular volume of gravel should be provided for each well.				
	5. Water samples shall be collected as per the standard procedures at the closure of well development as per the standard procedures. Water samples will be collected in 3 pre-treated HDPE containers (1 no. of 1 litre capacity container for Basic parameters, 2nos. of 250ml/500ml capacity containers for heavy metals). The samples for arsenic parameter should be acidified with ultrapure HCl (1:1 HCl) and the samples for other heavy/ trace metals should be acidified with ultrapure HNO ₃ (1:1 HNO ₃).				
	6. All the collected water samples shall be properly sealed and labelled with the relevant				

	details like location (including Lat and Long), well number and type, date and time of sampling, stage of pumping test/ well development, details of acidification, water temperature at the time of sample collection, etc.
	7 The water samples collected at the last stage of well development in case of Piezometer shall be analysed for basic parameters and heavy metals as per BOQ by the contractor through NABL Lab.
	8. Well development will be treated as completed only when water is clear and free of suspended particles during pumping. Well will be treated as completed only after construction of well as per the recommended well assembly and after conducting the well development and all other items mentioned in the BOQ including logging, submission of BDRs duly validated by CGWB. Payment for the well shall be made only when the well is constructed as per the BOQ specification.
	9. Litholog collected (minimum 250 g) as per BOQ should be properly packed in good quality packing cover and should be tagged with details of sample No, site name, well type, depth range of litholog, etc. and should be submitted to CGWB Regional office along with drill time log and logging details including logging graph.
	10. If additional quantity of any item is needed as per technical requirement at site, the same shall be decided by CGWB, NWHR in concurrence with the PMC, CGWB, CHQ.
	11. CGWB CHQ / CGWB, NWHR will not be responsible for any site related issues like rig / manpower, transportation, local disputes etc. at any point of time.

EXPLANATORY NOTE FOR BOQ's (Soft Rock)

PRICE: This is a works contract involving construction of wells as mentioned in the tender. The price is to be paid for supply and execution of work of various items or for materials

Explanatory notes in respect of each item of BOQ are given below. The BOQ shall be read in conjunction with explanatory notes of the concerned item along with Tender documents. The price shall be quoted accordingly.

1. Drilling of Pilot Hole in BOQ includes

- i. Site preparation and erection of tent with furniture to facilitate CGWB representative to discharge his duties at each site.
- ii. Drilling with 216mm(8 ½") RR/DRAG Bit to the targeted depth of 300m plus 5m, using bentonite mud.
- iii. Formation Sample collection (minimum 500g) during drilling for every 3m interval depth and also at the instance of change of formation during drilling (depth of change in formation to be recorded) and properly washed, dried and packed in polythene bags and labeled with date/ depth/ location
- iv. Maintain a drill time log for every 3 m and at depth where there is a change in formation(i.e. within 3m interval of litho log sample collection)
- v. Preparation and submission of litholog along with drill time log.
- vi. Any other activities pertaining to above drilling activity & recording of important information during drilling

2. Reaming of Hole in BOQ : includes

- i. Drilling with suitable minimum 381 mm (15")size RR/DRAG Bit to accommodate 150 mm (NB)casing pipes to the targeted depth(assembly depth plus 5m),as decided by CGWB site representative. Payment shall be restricted to actual depth of drilling or assembly depth plus 5m whichever is less.
- ii. CGWB site representative will decide the depth of assembly to be lowered.
- iii. If required, Formation Sample collection (minimum 500g) during drilling for every 3m interval depth and also at the instance of change of formation during drilling (depth of change in formation to be recorded) and properly washed, dried and packed in polythene bags and labeled with date/ depth/ location.
- iv. Maintain a drill time log for every 3 m and at depth where there is a change in formation (i.e. within 3m interval of litho log sample collection).
- v. Preparation and submission of litholog along with drill time log.
- vi. Any other activities pertaining to above drilling activity & recording of important information during drilling

3. Logging in BOQ: includes

- (i) electrical logging using 406mm and 1626mm (16" & 64") resistivity probe, SP and natural gamma logging up to the targeted depth (up to bottom depth of pilot hole) .
- (ii) In case the logging could not be completed to desired depth in 8 ½" pilot hole after repeated attempts, logging in larger dia hole may be allowed by site hydrogeologist and no additional payment will be made for enlargement of hole for logging purpose and for additional attempts of logging.
- (iii) Preparation of composite log and submission of report along with data and analysis as Proformagiven in section VIII
- (iv) Report should also include zonewise water Quality. The logging should decipher all the zones having at least one meter thickness.

- (v) Graph sheet, analysis etc. should be provided
- (vi) Any other related activities.

4. Enlargement of Hole in BOQ: includes

- i. Enlargement of hole with suitable minimum 508mm (20") size RR Bit to accommodate 250 mm (NB) (10") well assembly pipes to the targeted depth(assembly depth plus 5m),as decided by CGWB site representative in EW
- ii. CGWB site representative will decide the depth of assembly to be lowered.
- iii. Any other related activities

5. Supply and Installation of ERW Casing Pipes in BOQ: Includes

- i. Supply of 250mm (NB) (10")dia with thickness of 7.1mm(for EW) and 150mm(NB) (6")dia(for OW) with thickness of 5.4mm ERW casing pipe confirming to latest version of IS: 4270-2001 with pipe ends edges beveled, and the same should be inspected by Executive Engineer or the CGWB representative and accepted by him.
- ii. Lowering and Installation of the casing pipe including welding of pipes in the well
- iii. CGWB site representative will decide the assembly size and the depth to be lowered.
- iv. Any other related activities requiredfor supply and installation of casing pipe.

6. Supply and Installation of LCG V-wire Screen in BOQ: includes

- i. Supply and installation of 250mm (NB) (10")with thickness of 10 mm (for EW)and 150mm(NB) (6")(for OW)with thickness of 7.0 mm, LCG V-Wire screen with slot opening 1.0mm confirming to latest Version of IS:8110-200.
- ii. The material should be inspected by and approved by Executive Engineer or CGWB representative before lowering.
- iii. The length of slot and position of slot in the well assembly will be decided by CGWB representative.
- iv. Any other related activities requiredfor supply and installation of LCG pipe.

7. Supply and Shrouding by Pea Gravel in BOQ includes

- i. Supply and shrouding with pea gravel confirming to latest version of IS: 4097-1967 The Particle size range 2.0 mm to 3.35 mm for 1.0 mm slot opening.
- ii. The gravel before shrouding should be inspected and approved by the Executive Engineer or CGWB representative.
- iii. The depth up to which gravel shrouding is to be carried out will be decided by CGWB representative. The gravel shrouding shall be carried out after thinning the mud fluid using reverse fluid flow (back washing method).
- iv. Sufficient care should be taken so that gravel packing is proper and there is no bridging during gravel packing. If necessary, in case of bridging of gravel, air compressor of appropriate capacity should be used for proper gravel shrouding as per instruction of employer's site representative for which no additional cost will be paid. As a cross check, the theoretical annular volume of gravel packing and volume of actual gravel consumed shall be compared.
- v. Any other related activities

8. Cement Sealing in BOQ includes

- i. Before cement sealing, sounding should be carried out to ascertain correct depth of gravel shrouding.
- ii. Before cement sealing 1 m thick clay shall be provided above gravel.
- iii. Supply and cement sealing using 53 grade cement of 5m thickness.
- iv. Adequate rest(minimum 10 hrs) shall be provided after cement sealing.
- v. Any other related activities.

9. Supplying and filling up of borehole/ Annular space with clay in BOQ: includes

- i. Supply and filling up of bore hole/annular space between casing pipe and bore hole wall with clay balls as per the instruction of CGWB representative.
- ii. Any other related activities

10. Development by Air Compressor in BOQ: includes

- (i) Development of well by air compressor of adequate capacity, over pumping with VT/Submersible pump and/ or any other means till the water is clear and free from sand.
- (ii) Each slotted zones should be developed till discharge water becomes clear as decided by the CGWB representative.
- (iii) The two water samples (one for basic parameters analysis & one for heavy metals) shall be collected from OW following standard procedure in Polypropylene bottle(1 litre capacity) as per instruction CGWB representative.
- (iv) The water discharge from well during well development should be measured using V notch and recorded in the site register.

11. Chemical Analysis in BOQ: includes

- i. Supply of Polypropylene bottle(1 litre capacity) by the contractor
- ii. Collection of water samples in 1 litre Polypropylene bottles for analysis of basic parameters following standard procedure as per direction of CGWB site representative.
- iii. Transportation and chemical analysis of water sample in NABL accredited Lab
- iv. Each water sample shall be analysed for 15 parameters pH, EC, Total Hardness, Ca, Mg, Na,K,CO₃, HCO₃, SO₄, NO₃,Cl, F, PO₄ & Si
- v. Collection of water samples has to be carried out in all wells except dry wells
- vi. Submission of chemical analysis report (soft and hard copies) duly validated by employer
- vii. Any other activities pertaining to collection of water samples and water sample analysis

12. Chemical Analysis in BOQ: includes

- i. Supply of Polypropylene bottle(1 litre capacity) by the contractor
- ii. Collection of water samples in 1 litre Polypropylene bottles for analysis of heavy metals following standard procedure as per direction of CGWB site representative.
- iii. Transportation and chemical analysis of water sample in NABL accredited Lab
- iv. Each water sample shall be analysed for heavy metals Fe, Cu, Pb, Cd, Zn, Cr, Co and Ni
- v. Submission of chemical analysis report (soft and hard copies) duly validated by employer
- vi. Any other activities pertaining to collection of water samples and water sample analysis

13. Supply and Fitting of Well Cap in BOQ: includes :

- i. Supply and fitting of well cap in all wells as per specifications given in tender.
- ii. CGWB marking on pipes using welding.
- iii. Any other related activities

14. **Construction of Cement concrete platform in BOQ:** includes
- i. Construction of cement concrete platform measuring 0.70 X 0.70 X 0.60 m (0.30 m above ground level) using concrete mix of 1:2:4 around the housing pipe welded with anchoring plate 6 Nos as per drawing given in the section IX
 - ii. The area surrounding the well site has to be leveled, pits to be filled and the area to be restored to the original condition i.e. as before start of drilling operation and ensure all safety precautions.
 - iii. Any other activities required for well completion as mentioned in the section VII-Work requirements
15. **Supply and installation of protection box in BOQ:** includes
- i. Supply and installation of protection box as per specification given in tender document
 - ii. Supply of Brass lock (7 lever) with all common keys (One Key for multiple locks) preferably Make: Godrej/Harrison/Link with three individual keys for each well
 - iii. The above work is to be carried out in all wells
 - iv. Any other related activities
16. **Supply and Installation of Display board in BOQ:** includes
- i. Supply of Display Board as per Drawing: Display Board should be coated (minimum two coating) with antirust paint
 - ii. Installation of Display Board using concrete as per drawing. Each site will have one display board.
 - iii. Incorporation of details of well in the Display Board. In case of OW, details pertaining OW should be also incorporated in addition to Piezometer details as per the proforma given by the Employer's site representative. Any other information as desired by employer should also be incorporated in the Display Board.
 - iv. Any other activities related to supply and installation of Display Board.
17. **Preperation and Submission of BDR in BOQ:** includes
- i. Basic Data Report (BDR) along with data, graph sheet, analysis etc. as per proforma given in section VIII should be prepared for each site separately and submitted both in soft and hard copies. In site having both EW & OW the details (Litholog, static water level, drill time log etc.) pertaining to both EW & OW should be incorporated in the BDR.
 - ii. In case of site having more than one well, one BDR only be prepared but all the wells detail should be incorporated in that BDR.
 - iii. BDR Data and analysis should be duly validated and accepted by the Regional Director
 - iv. Any other activities

Note:

1. No payment will be made for the shiting of the rig unit and goods required for the construction of the wells as it is deemed to be included in the items cost of BOQ.
2. Wherever logging is conducted, the pilot hole depth in EW will be restricted to logging depth in case of variation between pilot hole depth and logging depth.

EXPLANATORY NOTE FOR BOQ's (Hard Rock/ Bouldery Formatioin)

PRICE: This is a works contract involving construction of wells and carrying out pumping test as mentioned in the tender. The price is to be paid for supply and execution of work of various items or for materials

Explanatory notes in respect of each item of BOQ are given below. The BOQ shall be read in conjunction with explanatory notes of the concerned item along with Tender documents. The price shall be quoted accordingly.

1. Drilling of Overburden in BOQ: includes

- i. Drilling with suitable size RR/DRAG/BUTTON Bit to accommodate suitable casing pipes as per BOQ to a depth till hard rock formation is encountered as decided by CGWB site representative
- ii. Formation Sample collection (minimum 250g) during drilling for every 3m interval depth
- iii. Recording of water discharge using V-notch on encountering formation with significant discharge. Depth at which formation with discharge encountered should be recorded,
- iv. Preparation and submission of litholog
- v. Providing tent along with table chairs etc. for employer site representative for discharging his duties smoothly
- vi. Any other activities pertaining to above drilling activity

2. Supply and Installation of ERW casing pipe of BOQ: includes

- i. Supply of suitable ERW casing pipe as per BOQ confirming to latest version of IS: 4270-2001 with thickness 5.4mm and the same should be inspected by the CGWB officer and accepted by him
- ii. Installation of 175mm casing pipe in the overburden
- iii. CGWB site representative will decide the length of casing pipe to be lowered
- iv Any other activities pertaining to above activity

3. Drilling by DTH method in BOQ: includes

- i. Drilling by DTH method using appropriate sizes of button bit so as to reach targeted depth with diameter of hole not less than 165mm up to 100m depth and final diameter not less than 152mm up to targeted depth (200m).
- ii. Formation Sample collection (minimum 250g) during drilling for every 3m interval depth or in the event of change in formation
- iii. Recording of water discharge using 90 degree V-notch (to be supplied by contractor) on encountering formation with significant discharge. Depth at which formation with discharge encountered should also be recorded
- iv. Preparation of litholog
- v. Above drilling by DTH had to be carried out in all 200m (EW & OWs)/ PZ of Package (Hard Rock)
- vi. Any other activities pertaining to above drilling activity

4. Collection of Water Sample in BOQ: includes

- i. Collection of water sample in 1 litre HDPE bottle during drilling i.e. on encountering formation with significant discharge, pumping tests, following standard procedure as per direction of CGWB site representative.
- ii. Supply of HDPE bottle(1 litre capacity) by the contractor
- iii. Transportation and chemical analysis of water sample in NABL accredited Lab
- iv. Each water sample shall be analysed for 15 parameters pH, EC, Total Hardness, TDS, Ca, Mg, Na,K,Co₃, HCO₃, SO₄, NO₃,Cl, F, Fe
- v. Collection of water samples has to be carried out in all wells except dry wells
- vi. Submission of chemical analysis report (soft and hard copies) duly validated by employer
- vii. Any other activities pertaining to collection of water samples and water sample analysis

5. Supply and fitting of Well Cap in BOQ: includes :

- i) Supply and fitting of well cap in all wells as per drawing,
- ii) Any other activities pertaining to supply and fitting of well cap

6. Construction of Cement Concrete Platform in BOQ: includes :

- i. Construction of cement concrete platform measuring 0.70 X 0.70 X 0.60 m (0.30 m above ground level) using concrete mix of 1:2:4 around the housing pipe welded with anchoring plate 6 Nos as per drawing given in the tender document.
- ii. Restoration of ground to previous natural condition

7. Supply and Installation of Protection box in BOQ: includes

- i. Supply and installation of protection box as per specification given in tender document
- ii. Supply of Brass lock (7 lever) with all common keys (One Key for multiple locks) preferably Make: Godrej/Harrison/Link with three individual keys for each well
- iii. Any other activities pertaining to installation of protection box

8. Preparation and submission of BDR in BOQ: includes

- i. Basic Data Report (BDR) along with data, graph sheet, analysis etc. should be prepared for each site separately and submitted both in soft and hard copies. In site having both EW & OW/ PZ the details (Litholog, static water level, depths at which discharge encountered and respective discharge measured using V-notch) pertaining to both EW & OW/ PZ should be incorporated in the BDR.
- ii. In case of site having more than one well, one BDR only be prepared but all the wells detail should be incorporated in that BDR.
- iii. BDR Data and analysis should be duly validated and accepted by the Regional Director.

9. PYT in BOQ: includes

- i. Supply of Infrastructure required for Preliminary Yield test education pipe, airline, steel tape of appropriate length for measuring the depth of well or water level recorder etc.
- ii. Lowering of education pipe and airline as per procedure mentioned in the tender document.
- iii. Conducting PYT as per procedure/methodology mentioned in the tender document
- iv. Measurement of water level at intervals as per procedure given in the pumping
- v. Installation of 20mm pipe for water level measurement
- vi. Recording of data and analysis of PYT Data generated as per proforma given in tender document
- vii. Arrangement for draining of discharge during pumping test to nearest drain safely through channels of pipes without creating hindrance to public

- viii. The PYT shall be carried out as decided by CGWB's site representative.
- ix. Submission of Data and analysis (Soft and hard copy) report duly validated by employer

10. **Slug test in BOQ:** includes

- i. Supply of Infrastructure required for slug test including arrangement of water needed for slug test, water level recorder etc.
- ii. Conducting Slug test as per the procedure given in the tender.
- iii. Measurement of static water level and also measurement of water level at closely spaced interval I during the test
- iv. The slug test shall be carried out in low yielding borewell/tubewells as decided by CGWB's site representative.

11. **Supply and installation of Display Board in BOQ:** includes

- i. Supply of Display Board as per Drawing: Display Board should be coated (minimum two coating) with antirust paint
- ii. Installation of Display Board using concrete as per drawing. Each site will have one display board.
- iii. Incorporation of details of well in the Display Board. In case of OW, details pertaining OW should be also incorporated in addition to EW details as per the proforma given by the Employer's site representative. Any other information as desired by employer should also be incorporated in the Display Board.
- iv. Any other activities related to supply and installation of Display Board.

Note:

No payment will be made for mobilization of rig unit and goods required for construction of wells as it is deemed to be included in the item's cost of BOQ.

SECTION-VII
TENTATIVE LIST OF LOCATIONS

SECTION-VII

TENTATIVE LIST OF LOCATIONS

Tentative list for Construction of Piezometer Wells through Out-sourcing in Laddakh.

LD PZ BOQ 1										
S.No	State	District	Block/ Assess ment Unit	Village	Longitud e	Latitud e	Depth	HR/SR	Purpose	
1	UT of Ladakh	Kargil	Kargil	Tungri Thagan	76.8132	33.5105	70-100 m	Bouldery formation	Seismic Zone IV and V	
2	UT of Ladakh	Kargil	Kargil	Karsha	76.905105	33.530321	70-100 m	Bouldery formation	Seismic Zone IV and V	
3	UT of Ladakh	Kargil	Kargil	Stongdae	76.9708	33.5114	70-100 m	Bouldery formation	Seismic Zone IV and V	
4	UT of Ladakh	Kargil	Kargil	Tsazar	76.9956	33.5646	70-100 m	Bouldery formation	Seismic Zone IV and V	
5	UT of Ladakh	Kargil	Kargil	Padum	76.8879	33.4632	70-100 m	Bouldery formation	Seismic Zone IV and V	
6	UT of Ladakh	Kargil	Kargil	Tungri	76.7764	33.5429	70-100 m	Bouldery formation	Seismic Zone IV and V	
7	UT of Ladakh	Kargil	Kargil	Shargole	76.2995	34.3914	70-100 m	Bouldery formation	Seismic Zone IV and V	
8	UT of Ladakh	Kargil	Kargil	Mulbekh	76.3771	34.3752	70-100 m	Bouldery formation	Seismic Zone IV and V	
9	UT of Ladakh	Kargil	Kargil	Wakha	76.4185	34.3643	70-100 m	Bouldery formation	Seismic Zone IV and V	
10	UT of Ladakh	Kargil	Kargil	Thasgam(laddakh)	75.9345	34.4959	70-100 m	Bouldery formation	Seismic Zone IV and V	
11	UT of Ladakh	Kargil	Kargil	Dras	75.7325	34.4345	70-100 m	Bouldery formation	Seismic Zone IV and V	
12	UT of Ladakh	Kargil	Kargil	Muski	75.6828	34.439	70-100 m	Bouldery formation	Seismic Zone IV and V	
13	UT of Ladakh	Kargil	Kargil	Bhimbut	75.8044	34.4264	70-100 m	Bouldery formation	Seismic Zone IV and V	
14	UT of Ladakh	Kargil	Kargil	Chanigou nd	76.0471	34.5986	70-100 m	Bouldery formation	Seismic Zone IV and V	
15	UT of Ladakh	Kargil	Kargil	Hundurman n	76.1113	34.6182	70-100 m	Bouldery formation	Seismic Zone IV and V	
16	UT of Ladakh	Kargil	Kargil	Olding	76.1635	34.7057	70-100 m	Bouldery formation	Seismic Zone IV and V	
17	UT of Ladakh	Kargil	Kargil	Marol	76.2182	34.7636	70-100 m	Bouldery formation	Seismic Zone IV and V	
18	UT of Ladakh	Kargil	Kargil	Hamzigon d	76.2012	34.806	70-100 m	Bouldery formation	Seismic Zone IV and V	
19	UT of Ladakh	Kargil	Kargil	Saliskote	76.0191	34.3996	70-100 m	Bouldery formation	Seismic Zone IV and V	
20	UT of Ladakh	Kargil	Kargil	Trespone	76.0393	34.4395	70-100 m	Bouldery formation	Seismic Zone IV and V	
21	UT of Ladakh	Kargil	Kargil	Gramthan g	76.0703	34.4655	70-100 m	Bouldery formation	Seismic Zone IV and V	
22	UT OF Ladakh	Kargil	Kargil	Chazar	77.008906	33.591228	70-100 m	Bouldery formation	Seismic Zone IV and V	
23	UT OF Ladakh	Kargil	Kargil	Chilingkit	77.005793	33.659442	70-100 m	Bouldery formation	Seismic Zone IV and V	
24	UT OF	Kargil	Kargil	Padam	76.87643	33.4620	70-100 m	Bouldery	Seismic Zone	

	Ladakh					53		formation	IV and V	
25	UT OF Ladakh	Kargil	Kargil	Pibcha	76.937487	33.349988	70-100 m	Bouldery formation	Seismic Zone IV and V	
26	UT OF Ladakh	Kargil	Kargil	Reru	76.96539	33.334399	70-100 m	Bouldery formation	Seismic Zone IV and V	
27	UT OF Ladakh	Leh	Leh	Chushul	78.656702	33.703676	70-100 m	Bouldery formation	Seismic Zone IV and V	
28	UT OF Ladakh	Leh	Leh	Durbuk	78.118229	34.104527	70-100 m	Bouldery formation	Seismic Zone IV and V	
29	UT OF Ladakh	Leh	Leh	Spangmik	78.459588	33.907785	70-100 m	Bouldery formation	Seismic Zone IV and V	
30	UT OF Ladakh	Leh	Leh	Matha	77.644924	33.997359	70-100 m	Bouldery formation	Seismic Zone IV and V	
31	UT OF Ladakh	Leh	Leh	Changa	77.707121	33.997359	70-100 m	Bouldery formation	Seismic Zone IV and V	
32	UT OF Ladakh	Leh	Leh	Martselang	77.736691	33.90576	70-100 m	Bouldery formation	Seismic Zone IV and V	
33	UT OF Ladakh	Leh	Leh	Palam	77.577949	34.170702	70-100 m	Bouldery formation	Seismic Zone IV and V	
34	UT OF Ladakh	Leh	Leh	Stok	77.652514	34.063721	70-100 m	Bouldery formation	Seismic Zone IV and V	
35	UT OF Ladakh	Leh	Leh	Sabu	77.616822	34.1267	70-100 m	Bouldery formation	Seismic Zone IV and V	
36	UT OF Ladakh	Leh	Leh	Chushot	77.621994	34.059865	70-100 m	Bouldery formation	Seismic Zone IV and V	
37	UT OF Ladakh	Leh	Leh	Stakma	77.621994	34.102013	70-100 m	Bouldery formation	Seismic Zone IV and V	
38	UT OF Ladakh	Leh	Leh	Ranbirpur	77.679591	34.028002	70-100 m	Bouldery formation	Seismic Zone IV and V	
39	UT OF Ladakh	Leh	Leh	Gangma	77.204585	34.729613	70-100 m	Bouldery formation	Seismic Zone IV and V	
40	UT OF Ladakh	Leh	Leh	Terche	77.562923	34.730781	70-100 m	Bouldery formation	Seismic Zone IV and V	
41	UT OF Ladakh	Leh	Leh	Diskit	77.657134	34.549568	70-100 m	Bouldery formation	Seismic Zone IV and V	
42	UT OF Ladakh	Leh	Leh	Tirit	77.646562	34.537584	70-100 m	Bouldery formation	Seismic Zone IV and V	
43	UT OF Ladakh	Leh	Leh	Alchi	77.170635	34.224061	70-100 m	Bouldery formation	Seismic Zone IV and V	
44	UT OF Ladakh	Leh	Leh	Khardung	77.670648	34.400863	70-100 m	Bouldery formation	Seismic Zone IV and V	
45	UT OF Ladakh	Leh	Leh	Sati	77.731532	34.477415	70-100 m	Bouldery formation	Seismic Zone IV and V	
46	UT OF Ladakh	Leh	Leh	Bazgo	77.285357	34.210432	70-100 m	Bouldery formation	Seismic Zone IV and V	
47	UT OF Ladakh	Leh	Leh	Khaltse	76.886991	34.320242	70-100 m	Bouldery formation	Seismic Zone IV and V	
48	UT OF Ladakh	Leh	Leh	Phyang	77.490022	34.185149	70-100 m	Bouldery formation	Seismic Zone IV and V	
49	UT OF Ladakh	Leh	Leh	Phe	77.321677	34.206246	70-100 m	Bouldery formation	Seismic Zone IV and V	
50	UT OF Ladakh	Leh	Leh	Sumur	77.619942	34.622537	70-100 m	Bouldery formation	Seismic Zone IV and V	
51	UT OF Ladakh	Leh	Leh	Fiang	77.492779	34.184181	70-100 m	Bouldery formation	Seismic Zone IV and V	
52	UT OF Ladakh	Leh	Leh	Gangales	77.612862	34.208275	70-100 m	Bouldery formation	Seismic Zone IV and V	
53	UT OF Ladakh	Leh	Leh	Tukcha	77.574357	34.164977	70-100 m	Bouldery formation	Seismic Zone IV and V	
54	UT OF Ladakh	Leh	Leh	Taroo	77.413812	34.186485	70-100 m	Bouldery formation	Seismic Zone IV and V	
55	UT OF Ladakh	Leh	Leh	Upshi	77.812528	33.83109	70-100 m	Bouldery formation	Seismic Zone IV and V	

56	UT OF Ladakh	Leh	Leh	Tangtse	78.1706	34.0323 39	70-100 m	Bouldery formation	Seismic Zone IV and V	
57	UT OF Ladakh	Leh	Leh	Airforce-station leh	77.529377	34.1350 14	70-100 m	Bouldery formation	Seismic Zone IV and V	
58	UT OF Ladakh	Leh	Leh	153 General Hospital Leh	77.567752	34.1709 94	70-100 m	Bouldery formation	Seismic Zone IV and V	
59	UT OF Ladakh	Leh	Leh	Jamyang school	77.574440 79	34.1453 95	70-100 m	Bouldery formation	Seismic Zone IV and V	
60	UT OF Ladakh	Leh	Leh	Sonam Norboo Memorial Hospital	77.58104	34.1537 62	70-100 m	Bouldery formation	Seismic Zone IV and V	
61	UT OF Ladakh	Leh	Leh	Leh Donkey Sanctuary	77.587317	34.1821 34	70-100 m	Bouldery formation	Seismic Zone IV and V	

Note: The location above are Tentative and may be changed

SECTION-VIII

FORMATS FOR SUBMISSION OF DATA

SECTION-VIII

FORMATS FOR SUBMISSION OF DATA

Annexure A

LOGGING DATA (NATURAL GAMMA LOGGING)

Unique ID	
Location	
Block	
District	
Toposheet Number	
Latitude in Degree Decimal	
Longitude in Degree Decimal	
Site plan and RL(m amsl)	
Date/Year	
Depth Drilled (m bgl)	
Depth Logged (m bgl)	
Bore hole dia.	

Unique ID

Depth range (m bgl)		Thickness (m)	Natural Gamma counts (CPS)	Inferred Lithology	Ground water Quality
From	To				

Signature and stamp of Authorized signatory

LOGGING DATA (CALIPER LOGGING)

Unique ID	
Location	
Block	
District	
Toposheet Number	
Latitude in Degree Decimal	
Longitude in Degree Decimal	
Site plan and RL(m amsl)	
Date/Year	
Depth Drilled (m bgl)	
Depth Logged (m bgl)	
Bore hole dia.	

Unique ID

S.No.	Depth range (m bgl)		Thickness (m)	Borehole Diameter	Remarks
	From	To			

Signature and stamp of Authorized signatory

**PRELIMINARY YIELD TEST(PYT)
(IF SPECIFIED IN BOQ)**

Site name with coordinates				
Location details				
Block				
District & State				
Type of Well				Pumping well
Date of Test & Start time				
Diameter of well (mm)				
Discharge (lps)				
Measuring Point (m)				
SWL in m below measuring point				
Time since pump started (min) (t)	Time since stopping of pumping (min) (t')	Water level (m bmp)	Residual Drawdown RDD (m)	t/t'
Interval for Recording of data.				
1 minute interval upto 10 min				
2 minute interval upto 20 min				
1				
2				
3				
4				
5				
6				
7				
8				
9				
10				
12				
14				
16				
18				
20				
25				
30				
5 minute interval upto 50 min				
10 min recording upto 100 min				
20 min recording upto 200min				
50 min recording until 500 min				
100 min recording until 90% recuperation to Static water level.				

SLUG TEST DATA SHEET (IF SPECIFIED IN BOQ)

Well no: _____ Date of test _____

Location:

Administrative Block: _____ District: _____ State _____

Latitude (Degree Decimal) : _____ Longitude(Degree Decimal): _____ Toposheet no: _____

Well Details:

Type of Well: BW/TW Owner: Govt/Private. Well usage: Irrigation/Domestic Well status: In use/Abandoned

Geologic formation _____ Depth of the well: _____ (m). Diameter of Well : _____ (mm) Casing length _____ (m) Reported discharge _____ lps.

Alluvial area/Hard rock/ **Bouldery Formatioion** area: Zones tapped/Fractures encountered from _____ to _____ (m).**Test Reading**

Measuring point (MP) _____ (m) Static WL _____ (m) Slug Quantity(Injection) _____ litre.

Time of start of test _____ Time of Completion of test _____ Length of test _____ (Minutes)

Results:**Analysis method**

Type of aquifer: Unconfined/Confined. Method used for Analysis: _____

Aquifer parameters:Transmissivity _____ m²/d and Hydraulic Conductivity (K) _____ m/d.

Name of personnel conducted test

Signature

Date

SLUG TEST - DATA SHEET (IF SPECIFIED IN BOQ)

Site name				
Latitude (Degree Decimal)				
Longitude (Degree Decimal)				
Block				
District & State				
Volume of Slug injected (litres)				
Diameter of well (mm)				
Date of Test				
Height of M.P (m.agl)				
SWL in m below measuring point (m)				
Time (min)	Time (sec)	Water level (H) in m	Change in Water Level (Ho) in m	H/Ho
1				
2				
3				
4				
5				
6				
7				
8				
9				
10				
12				
14				
16				
18				
20				
25				
30				
35				
40				
45				
50				
55				
60				
65				
70				
75				
80				
85				
90				
95				
100				

CONSOLIDATED STATEMENT OF SLUG TEST (IF SPECIFIED IN BOQ)

Sl.no	Village name	Lat	Long	Depth of well	Geological formation	K value (m/d)		
						Hvorslev method	Bouwer and Rice method	Cooper et al
1								
2								
3								
4								
5								
6								
7								
8								
9								
10								

WELL INVENTORY - DATA SHEET

Well no: _____ Date of inventory _____

Location :

Administrative Block: _____ District: _____ State _____

Latitude: _____ Longitude: _____ Toposheet no: _____

Name of the Watershed _____ Area of the Watershed _____ km²

Geologic formation _____

Type of Well: DW/DCB/BW* Owner: Govt/Pvt. Well usage: Irrigation/Domestic.

Depth of the well : _____ (m). Diameter of Well : _____ (mm)

Casing length/ Curbing depth (m _____ (m) Reported discharge _____ lps.

Weathering thickness) _____ m Fractures encountered from _____ to _____ (m).

Measuring point (MP) _____ (m) Static WL _____ (m) Type of Pump- Submersible/Centrifuge/JET Pump Capacity _____ (HP) Hours of pumping _____ hrs/day. Number of pumping days _____

days /year. Total estimated draft _____ m³/year.

Cropping pattern _____

Command area of the well _____ ha.

Any other Salient feature : _____

Name of officer

GOVERNMENT OF INDIA
MINISTRY OF JAL SHAKTI
CENTRAL GROUND WATER BOARD

BASIC DATA REPORT

**BASIC DATA REPORT OF PIEZOMETER WELL
AT (Name of Village), (Name of block)
District / State**

**By
Agency**

Under overall supervision of

**(Name of region)
Regional HQ
Month/ year**

BASIC DATA REPORT OF PIEZOMETER WELL
AT (Name of Village), (Name of block)
District / State

CONTENTS

1. Location
2. Purpose of drilling
3. Drilling history
4. Geology
- 4.1 Sub surface geology
5. Geophysical logging
6. Well Assembly
7. Hydro-Chemistry

A. Plates

1. Site plan.
2. Litho log and Well designs
3. Gamma/ Calliper/Electrical log - Analog

Annexures

1. Drill time log

GOVERNMENT OF INDIA
MINISTRY OF JAL SHAKTI
CENTRAL GROUND WATER BOARD
(Name of region)
Regional HQ

1. **BASIC DATA REPORT**

LOCATION : --

BLOCK : ---

DISTRICT/ state : --

CO-ORDINATES : Long: A⁰ B/C // E
Lat: X⁰ Y/Z // N

SURVEY OF INDIA TOPO SHEET NO. :

BASIC DATA REPORT OF PIEZOMETER WELL
AT (Name of Village), (Name of block)
District / State

1. LOCATION

Give details of site, alongwith location approach

2. PURPOSE AND SCOPE

Describe the purpose and scope of ground water exploration

3. DRILLING HISTORY

Brief history of various activities and methods applied in carrying out ground water exploration. In respect of soft rock, depth at which fracture encountered and discharge measured during drilling of each fracture zone etc. to be furnished.

4. GEOLOGY

Give general geology of the area

4.1 SUB SURFACE GEOLOGY

Litholog

Lithology	Depth range (m)		Thickness (m)
	From	to	

Composite log

Lithology	Depth range (m)		Thickness (m)
	From	to	

5. ELECTRICAL/ NATURAL GAMMA LOGGING OF BOREHOLE

Alluvium Areas: Zones deciphered on the basis of Electrical/ Natural Gamma logging

S.No.	Depth range (m bgl)		Thickness (m)	Ground water Quality EC/(TDS)
	From	To		

Hard Rock/ Bouldery Formatioin Area : Weathered/Fractured Zones deciphered on the basis of Calliper logging

S.No.	Depth range (m bgl)		Thickness (m)	Borehole Diameter	Remarks
	From	To			

6. WELL ASSEMBLY

Well assembly of PIEZOMETER well

Depth range m (bgl)	Length (m)	Dia (mm)	Slot size(mm)	Description

1. CHEMICAL QUALITY OF GROUND WATER

Table: Results of chemical analysis of water samples

Water sample	Constituents										
	pH	EC micro mhos /cm at 25 ^o c	2 H CO ₃	Cl	NO ₃	F	Ca	Mg	Na	K	Total hardness as CaCO ₃
Heavy metals											

8.0 WELL DIAGRAM

In respect of soft rock formation and soft boulder formation:-

Well diagram with details of final reamed dia, well assembly (blank and screen position) with assembly size and depth, gravel packing and its depth, cement sealing with depth, clay packing and depth, concrete platform and static water level.

In respect of hard rock formation:-

Well diagram with details of overburden drilling dia, casing pipe length, dia, naked well dia, fracture zone and it's depth and it's depth, part assembly (blank/ screen position) cement sealing with depth, clay packing and depth, concrete platform and static water level.

SECTION-IX
DRAWINGS

Section-IX

ANNEXURE- N

SAMPLE DRAWING OF HOUSING PIPE (Top View) & WELL CAP

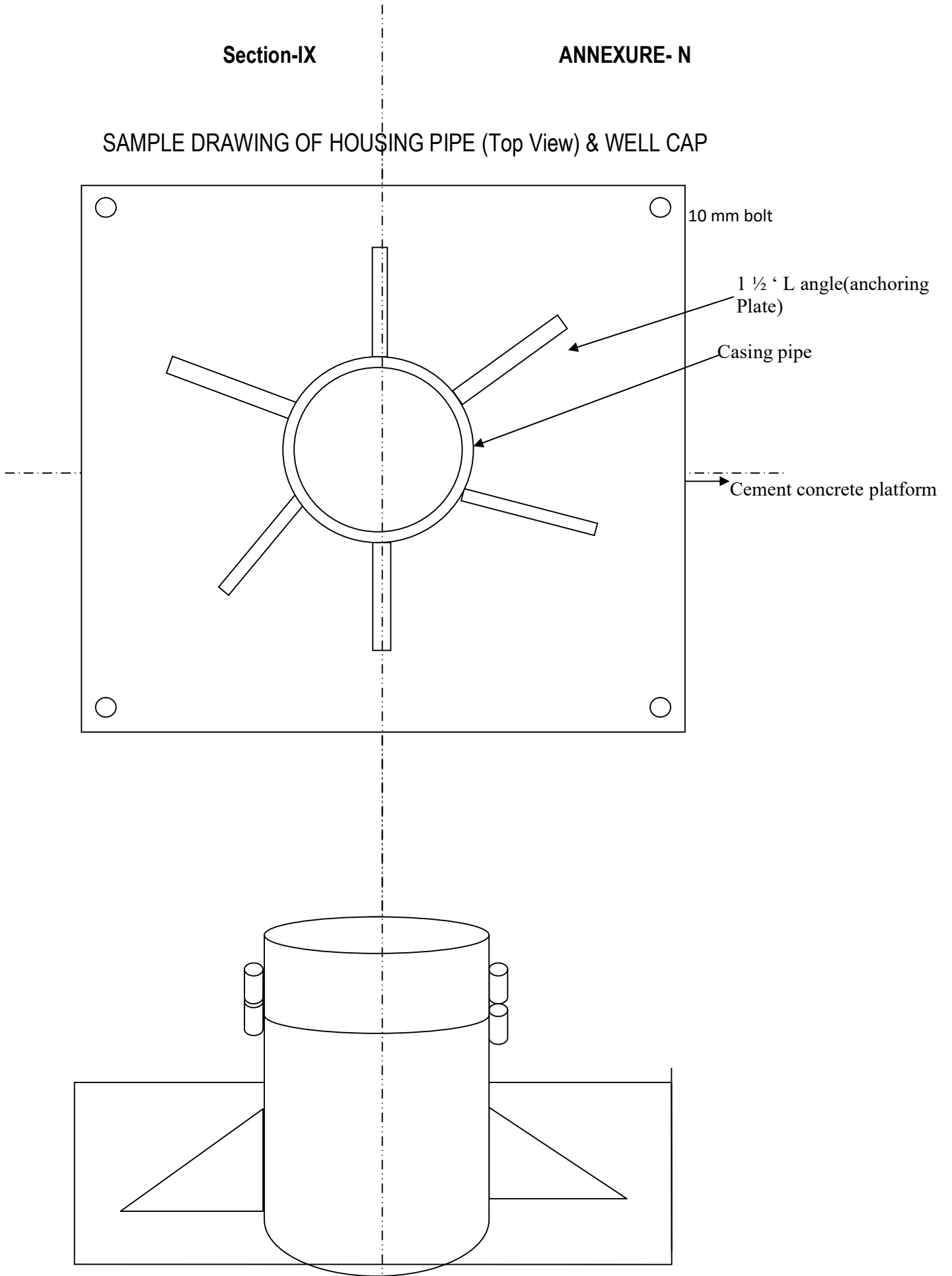

(SAMPLE DRAWINGS) Annexure-O

Well cap

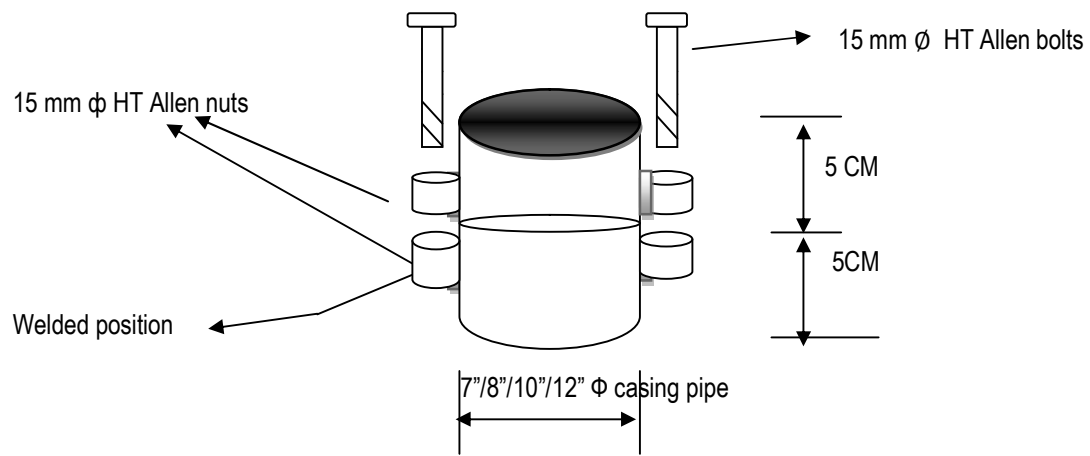

(SAMPLE DRAWINGS) Annexure- P

Cement concrete platform

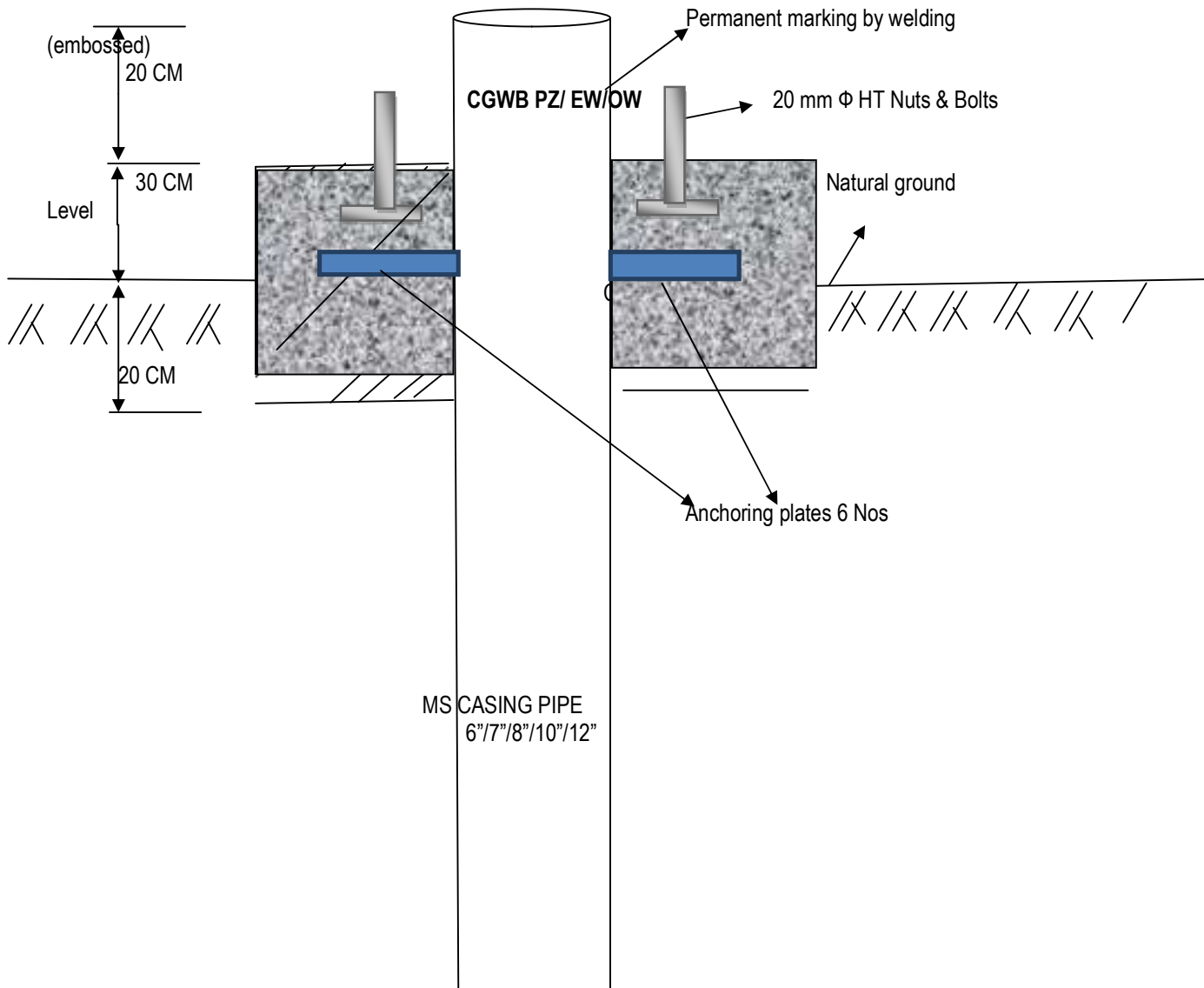

A cement/ concrete platform measuring 0.70 X 0.70 X 0.60 m (0.30 m above ground level and 0.30m below ground level) around the well casing is to be provided over which protection box is to be provided. The concrete mix ratio is 1:2:4

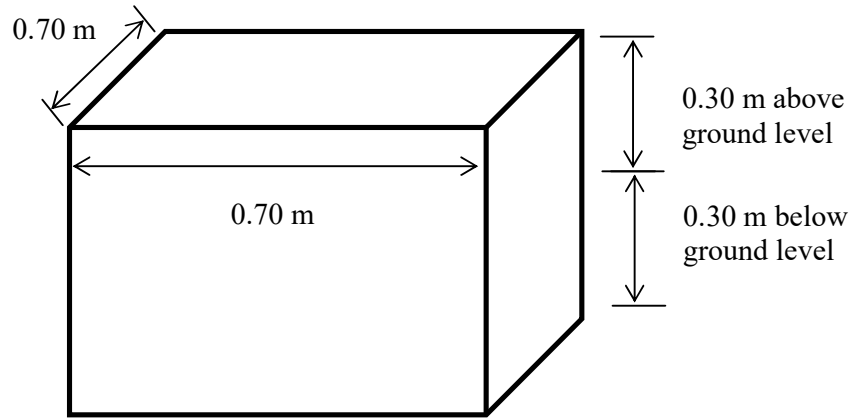



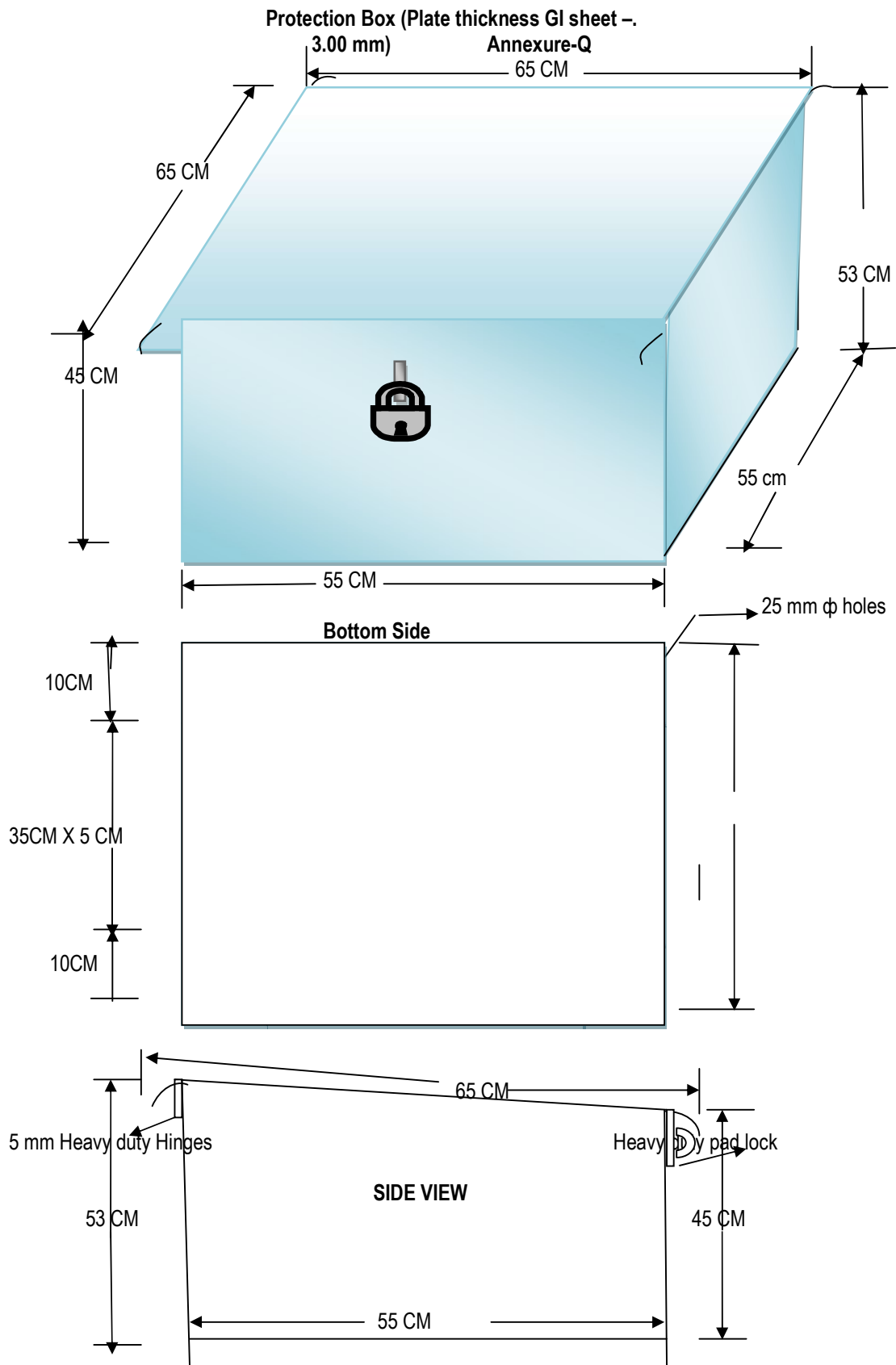

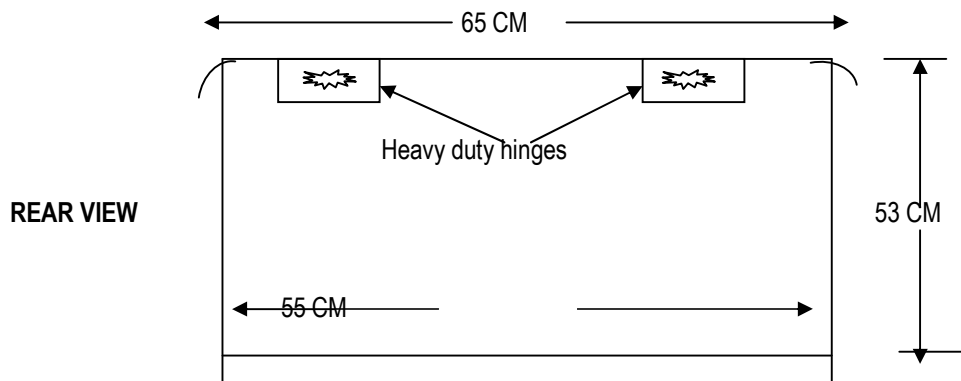
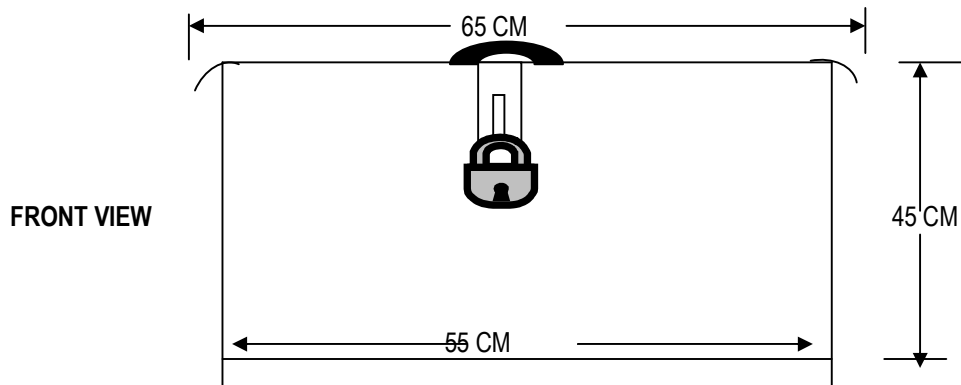

COVER PLATE OF SIZE:
65 CM X 65 CM (with HANDLE and LOCK).
 The cover plate should have minimum 5 CM extra projection on all sides of box for safeguarding the box and lock against rainfall.
 The edges of sheet should not be sharp but should be rounded off.
 The thickness of the plate should be made of 3.00 mm GI sheet.
 Aluminium paint on all over welded joints
 Perforation shall be provided in the Protection Box on two sides

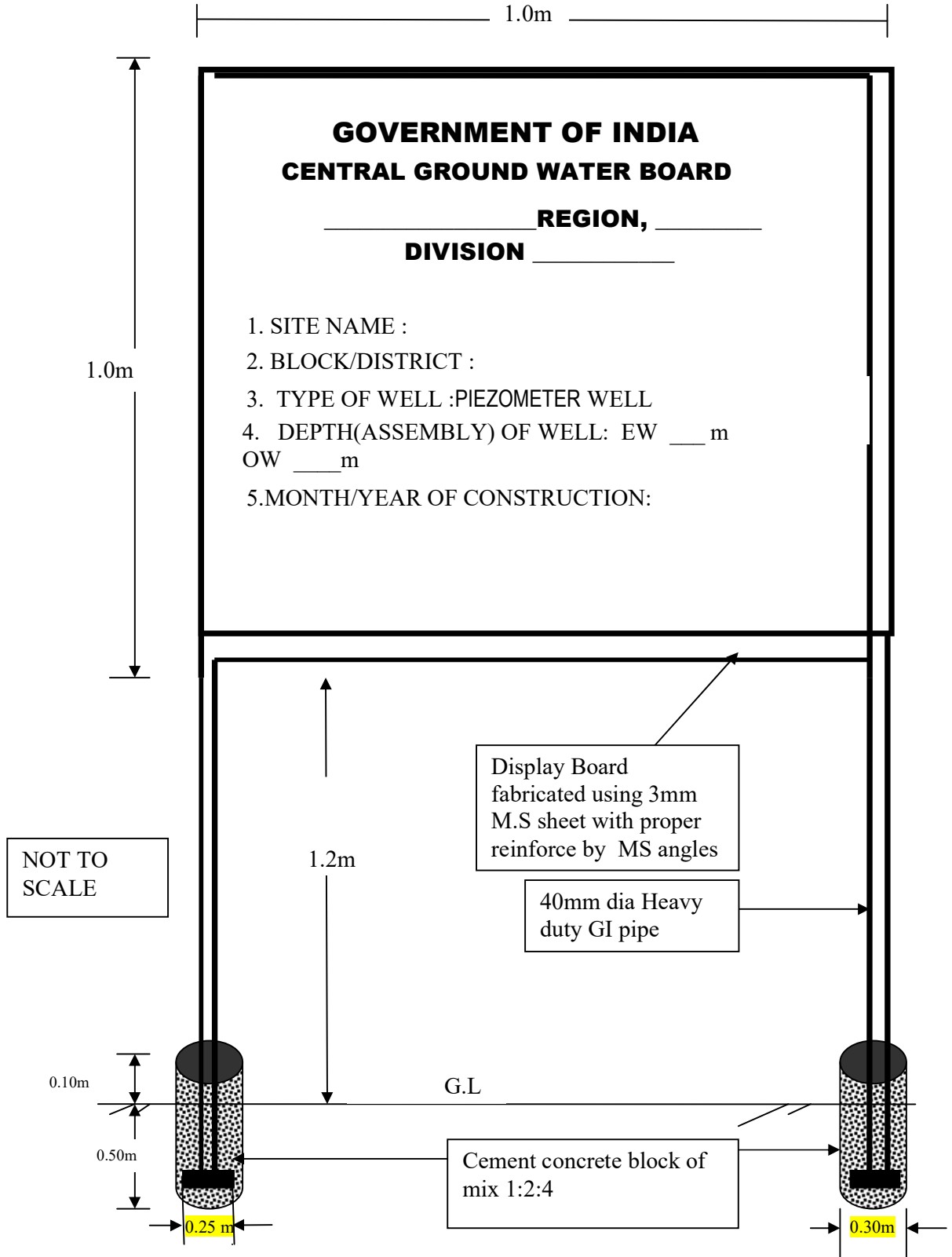

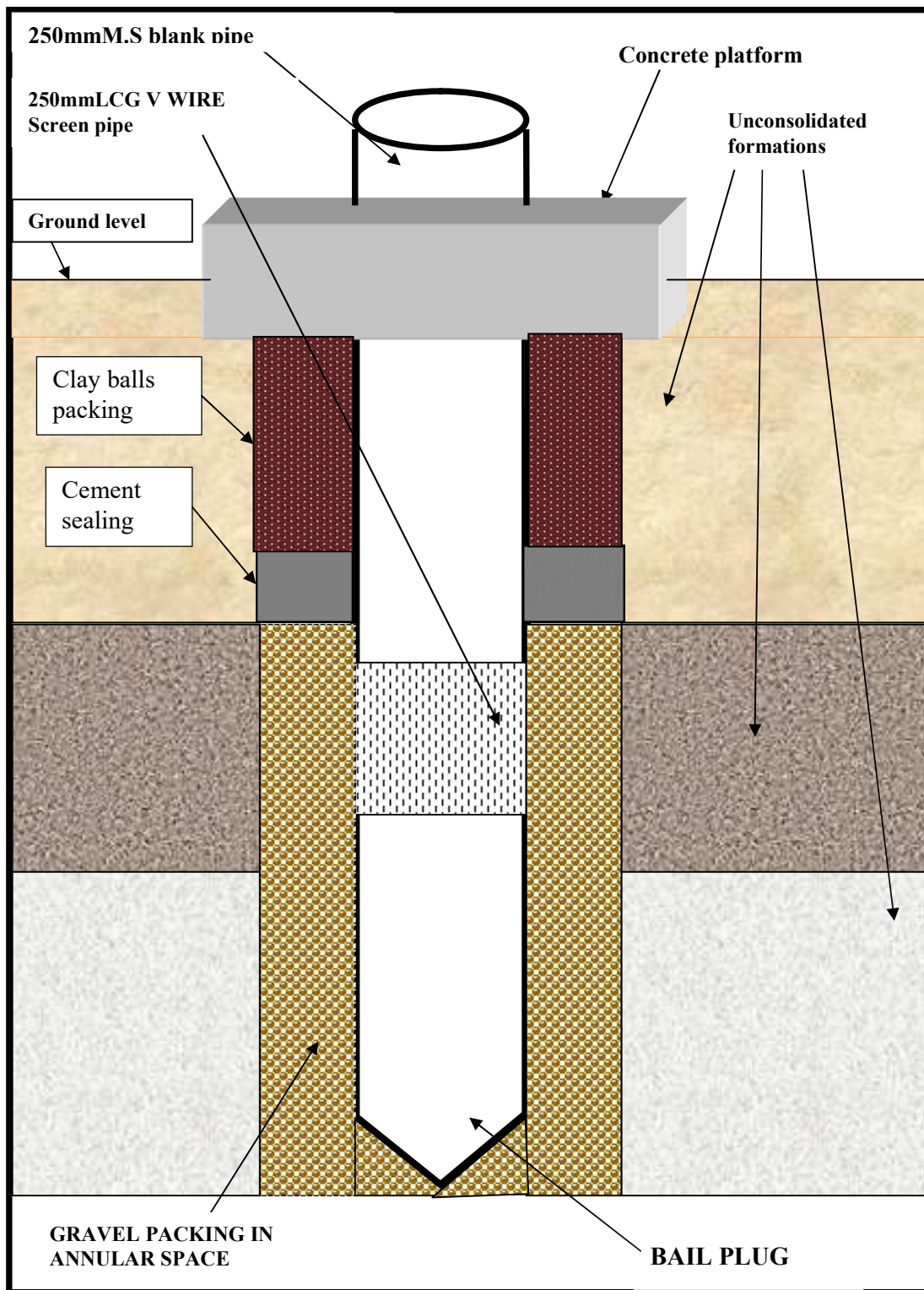

SAMPLE DESIGN OF PIEZOMETER WELL SOFT ROCK FORMATIONS.THE ACTUAL DESIGN WILL BE DECIDED BY THE SITE HYDROGEOLOGIST WITH THE APPROVAL OF REGIONAL DIRECTOR.

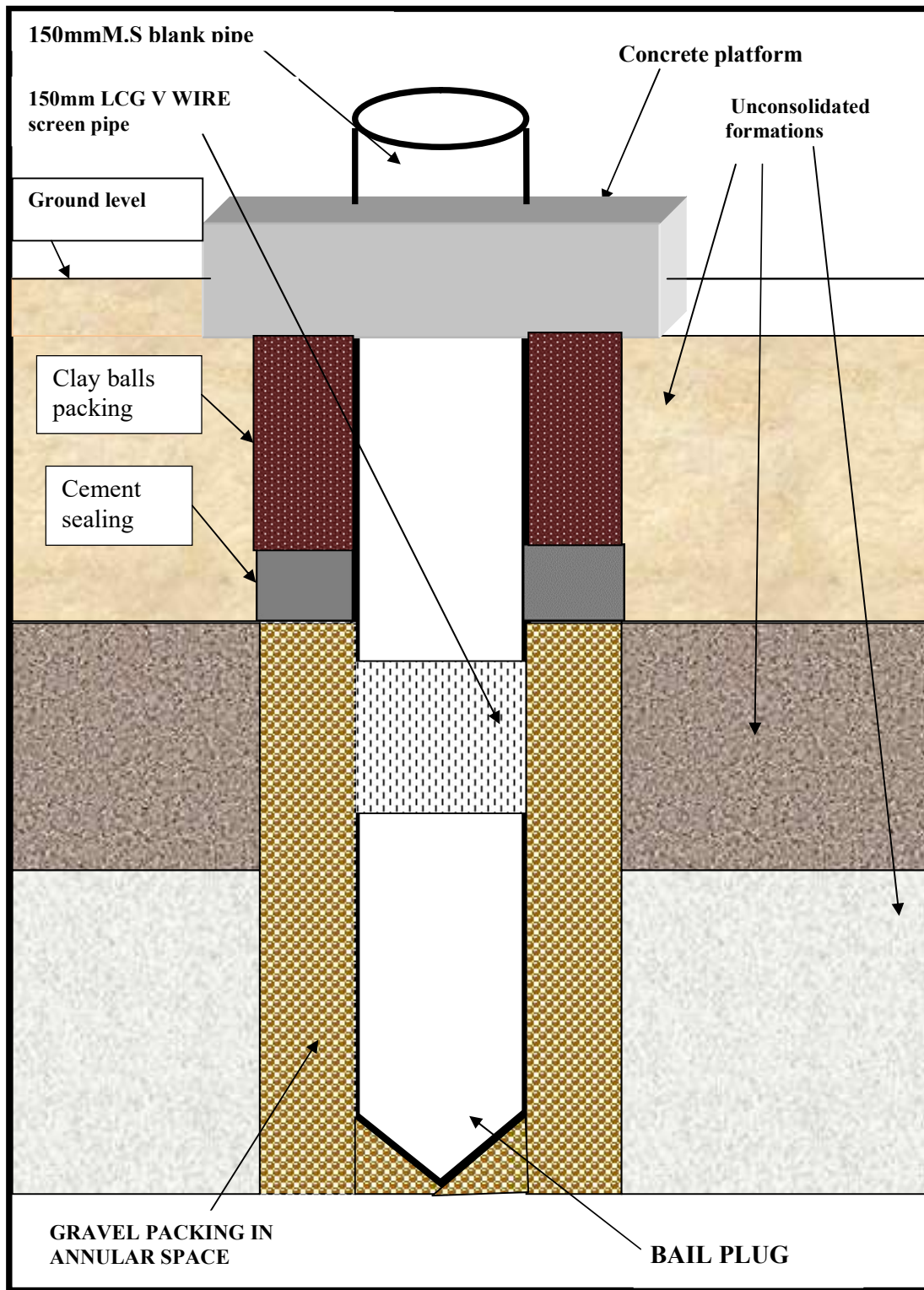

SAMPLE DESIGN OF PIEZOMETER WELL IN SOFT ROCK FORMATIONS.THE ACTUAL DESIGN WILL BE DECIDED BY THE SITE HYDROGEOLOGIST WITH THE APPROVAL OF REGIONAL DIRECTOR.

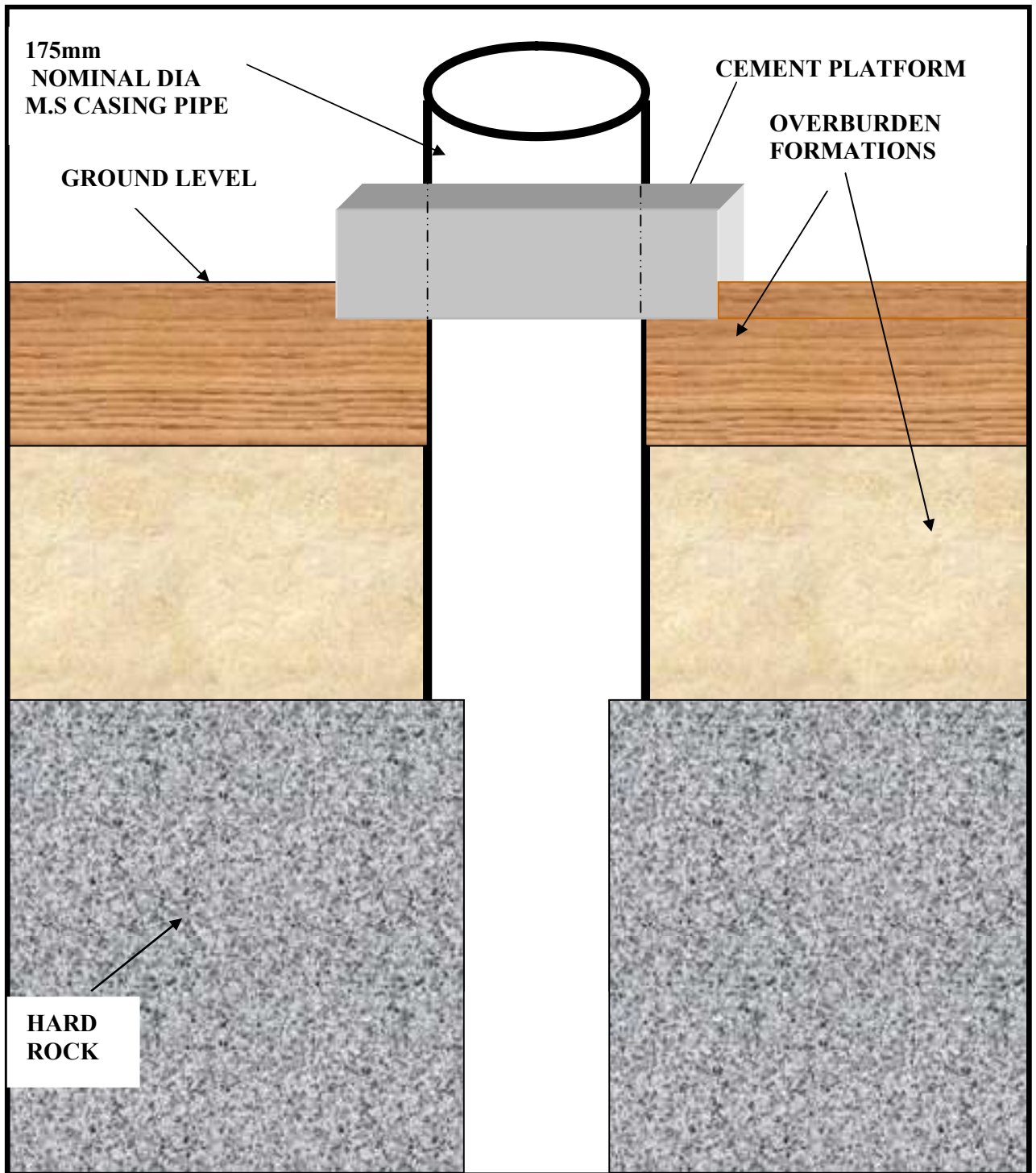

FIG: SAMPLE DESIGN OF 200m Depth PZ/ EW& OW IN HARD ROCK/ Bouldery Formatioin (sample figure)

SECTION- X
BIDDING DATA

SECTION- X

BIDDING DATA

Summary of Works:

(Construction of 61 Piezometer in the UT of Laddakh.

Name and address of the employer- **Chairman, Central Ground Water Board, Bhujal Bhawan, NH-IV Faridabad-121001 (Haryana)**

Period of bid validity- **120 Days**

Amount of earnest money

Tender ID	Name of Package	Region	Estimated Cost in INR excluding GST	EMD in INR
	Package 8-C	Laddakh	5,14,84,000/-	10,29,680/-

Venue, time and date of bid opening- Bhujal Bhawan, NH-IV, **Central Ground Water Board, Faridabad-121001**

Standard form and amount of performance guarantee acceptable to the employer in **Section-XIII and 3% of the Bid Price**

Security Deposit:**As per tender document**

Bill of Quantities (as per standard form)-

The summary of package has been provided in Section-VI (Bill of Quantities and Summary of package). The detailed Bill of Quantities for PACKAGE-8 C of UT of Laddakh may be seen in the BOQ section uploaded in the e-tendering system which is an integral part of this tender document.

Clause 3.1

- i) Time allowed for submission of Performance Guarantee from the date of issue of letter of acceptance. - **21 days**
- ii) Maximum allowable extension beyond the period provided in i) above- **7 days**

Clause 4.1

Specifications to be followed for execution of work – **As defined in following sections:**
Section-V Scope of work and Technical Specifications
Section-VI Bill of Quantities and Summary of Packages

Clause 4.2

Maximum percentage for quantity of items of work to be executed beyond

which rates are to be determined in Accordance with Clauses –4.2.

- Clause 4.3** Competent authority for deciding reduced rates **Chairman, CGWB**
- Clause 4.4** Defects Liability Period **365 days from the date of completion of work**
- Clause 4.6**

Requirement of Technical Representative(s) and Recovery Rate

S.No.	Minimum Qualification of Technical Representative	Discipline	Designation (Principal Technical/Technical representative)	Minimum experience	Number	Rate at which recovery shall be made from the contractor in the event of not fulfilling provision of Clause 4.6	
						Figures	Words
1	Graduate Degree in Engineering / Master's Degree in Geosciences	Engineering / Geosciences	Groundwater Professional	Minimum 3 years of experience in construction of water wells, borehole logging, conducting pumping tests, interpreting/analysing related data and preparation of reports.	Minimum one	Rs.2000/- per day	Rupees Two Thousand per day

Retired Government Officer served at minimum level of Assistant Engineer or equivalent with Diploma qualification will be treated at par with Graduate Engineers.

Clause 8.1

Number of days from the date of issue of letter of acceptance for reckoning date of start **15 days**

Time allowed for execution of work **300 days**

Authority to give fair and reasonable extension of time for completion of work with and without Liquidated Damages

S.N	Authority	Extension of time
1	DoWR, RD&GR	Full Powers

Clause 8.2

Competent authority for fixing compensation **Chairman CGWB**

Clause 9.1

Dispute resolution board shall consists of following members

- i) The concerned Member, CGWB under whose jurisdiction the work is being executed**
- ii) The FAO, CGWB**
- iii) The Regional Director, CGWB of the concerned Region/s.**
- iv) The Superintending Engineer, CGWB under concerned Member.**

Clause 9.2

Appointing authority for Arbitrator **Chairman, CGWB**

SECTION- XI
FORMATS
FOR
QUALIFICATION INFORMATION

SECTION- XI

FORMATS FOR QUALIFICATION INFORMATION

- 1 The information to be filled in by the Bidder in the following pages will be used to ascertain responsiveness of the bidder as per eligibility criteria provided for in Clause 2 of the Instructions to Bidders. This information will not be incorporated in the Contract.

1.1 For Individual Bidders

(Refer Clause 2.2 of ITB)

Constitution or legal status of Bidder:

[Attach copy]

Place of registration:

[Attach copy of Registration Certificate]

Principal place of business:

Power of attorney of signatory of Bid:

[Attach copy]

2 Annual turnover for last three financial years

(Refer Clause 2.3 of ITB)

Financial Year	Turnover (INR)

3 (a) Details of similar works successfully completed during last seven years
(Refer Clause 2.4 of ITB)

Financial Year	S. No.	Employer	Work order/ Agreement reference	Description of Work	Date of Completion	Value of Contract	Page No of documentary proof enclosed in the bid
	1. 2. 3						

*Documentary proof from Employer should be enclosed

(b)Details for proof of payment in respect of Works mentioned in Table 3(a) .
(Refer Clause 2.4 of ITB)

SI No.	Name of the Employer	Work Order/ Agreement Reference	Payment Recieved	Page no of Documentary proof for payment received enclosed in the Bid

4. Details of tubewells/ borewells constructed by the bidder during last seven years
(Refer Clause 2.6 of ITB)

S. No.	Type of formation /strata viz. Hardrock, Softrock, Coal, Gas etc	Depth of Well	No. of Wells	Page Nos of Documentary proof given in this regard

Note: The final decision in respect of Type of formation/strata viz. Hardrock, Softrock/Alluvial etc. shall be of CGWB and shall be binding to the bidders.

5. In case of a consortium, attach certified copy of the agreement between various partners identifying the parts and components of the system for which the concerned partner is responsible for execution. Furnish the information as required under Clause 1 to 4 for each partner individually (Refer Clause 2.2 of ITB).
6. Please provide a complete plan of operation for executing the work of packages bid for in the timeframe prescribed for completion of work, including information about availability of drilling rigs and other drilling/geophysical equipment (owned/ hired/ leased/ to be procured).

7. Checklist for EMD

S.N.	Name of item	EMD in INR	Form of EMD (Account Payee Demand Draft/Fixed Deposit Receipt/Banker's Cheque/Bank Guarantee)	Amount of EMD (Amount shouldn't be less than the amount mentioned in Col.3)	Date of issue of EMD	EMD Expiry Date (EMD shall be valid for a period of (120 + 60) = 180 days from the last date of submission of bid*)
1	2	3	4	5	6	7

*In case last date of submission of bid has been extended, 180 days shall be counted from extended date.

----XXXXXXXXXX----

SECTION- XII

BANK GUARANTEE FORM FOR EMD

SECTION- XII

BANK GUARANTEE FORM FOR EMD

To

The President of India
Acting through
Drawing & Disbursing Officer, Central Ground Water Board, Bhujal Bhawan, NH-IV,
Faridabad-121001.

WHEREAS {Name and Address of Tenderer} (hereinafter called "the tenderer") has submitted its quotation (hereinafter called the "tender") dated {} for supply of {Short Description of Goods and Services} against the Employer's tender inquiry No. {} dated {}

Know all persons by these presents that we {Name of Bank}(hereinafter called the "Bank") having our registered office at {Address of Bank}are bound unto {Name of Employer}(hereinafter called the "Employer") in the sum of {Amount} for which payment will and truly to be made to the said Employer, the Bank binds itself, its successors and assigns by these presents.

Sealed with the Common Seal of the said Bank this{Specify Day} day of {Specify Month and Year}.

The conditions of this obligation are:

- (a) If the Tenderer withdraws or amends, impairs or derogates from the tender in any respect within the period of validity of this tender.
- (b) If the Tenderer having been notified of the acceptance of his tender by the Employer during the period of its validity:
 - (i) fails or refuses to furnish the performance security for the due performance of the contract.
 - (ii) fails or refuses to accept/execute the contract.

We undertake to pay the Employer up to the above amount upon receipt of its first written demand, without the Employer having to substantiate its demand, provided that in its demand the Employer will note that the amount claimed by it is due to it owing to the occurrence of one or both the two conditions, specifying the occurred condition(s).

This guarantee will remain in force for a period of 60 (sixty) days after the period of tender validity and any demand in respect thereof should reach the Bank not later than the above date.

{Signature of the Authorised Officer of the Bank}
{Name and Designation of the Officer}
{Seal, Name & Address of the Branch of the Bank}

SECTION- XIII
BANK GUARANTEE FORM
FOR
PERFORMANCE SECURITY AND MOBILISATION ADVANCE

SECTION- XIII

BANK GUARANTEE FORM FOR PERFORMANCE SECURITY

To
The President of India
Acting through
Drawing & Disbursing Officer, Central Ground Water Board, Bhujal Bhawan,
Faridabad

WHEREAS {Name and Address of Supplier} (hereinafter called "the supplier") has undertaken, in pursuance of Contract No {} dated {} to supply {Short Description of Goods and Services} (herein after called "the contract").

AND WHEREAS it has been stipulated by you in the said contract that the supplier shall furnish you with a bank guarantee by a scheduled commercial bank recognised by you for the sum specified therein as security for compliance with its obligations in accordance with the contract;

AND WHEREAS we have agreed to give the supplier such a bank guarantee;

NOW THEREFORE we hereby affirm that we are guarantors and responsible to you, on behalf of the supplier, up to a total of {amount of the guarantee in words and figures}, and we undertake to pay you, upon your first written demand declaring the supplier to be in default under the contract and without cavil or argument, any sum or sums within the limits of {amount of the guarantee }, as aforesaid, without your needing to prove or to show grounds or reasons for your demand or the sum specified therein.

We hereby waive the necessity of your demanding the said debt from the supplier before presenting us with the demand.

We further agree that no change or addition to or other modification of the terms of the contract to be performed thereunder or of any of the contract documents which may be made between you and the supplier shall in any way release us from any liability under this guarantee and we hereby waive notice of any such change, addition or modification.

This guarantee shall be valid up to and including the {Specify Day} day of {Specify Month and Year}.

{Signature of the Authorised Officer of the Bank}
{Name and Designation of the Officer}
{Seal, Name & Address of the Branch of the Bank}

PROFORMA FOR BANK GUARANTEE FOR ADVANCE FOR MOBILISATION

To
The President of India
Acting through
Drawing & Disbursing Officer, Central Ground Water Board, Bhujal Bhawan, Faridabad

In consideration of Central Ground Water Board (hereinafter referred to as "the Employer") which expression shall, unless repugnant to the context or meaning thereof include its successors, administrators and assigns) having awarded to _____(Contractor's name) with its Registered /Head Office at _____(hereinafter referred to as "the Contractor " which expression shall unless repugnant to the context or meaning thereof, include its successors, administrators, executors and assigns) a contract, by issue of Employer's Notification of Award No. _____dt. _____and the same having been unequivocally accepted by the Contractor, resulting into a contract valued at Rs. _____ (Rupees)_____only) for _____ (hereinafter called " the contract") and the Employer having agreed to make an advance payment to the Contractor for performance of the above Contract amounting to Rs. _____(Rupees _____only) as an advance against bank guarantee to be furnished by the Contractor.

We, _____(name & address of bank) having its Head Office at _____(hereinafter referred to as "the Bank" which expression shall, unless repugnant to the context or meaning thereof, include its successors, administrators, executors and assigns) do hereby guarantee and undertake to pay the Employer immediately on demand any or, all monies payable by the Contractor to the extent of Rs. _____ (Rupees _____only) as aforesaid at any time upto _____without any demur, reservation, contest , recourse or protest and/or without any reference to the Contractor. Any such demand made by the Employer on the bank shall be conclusive and binding notwithstanding any difference between the Employer and the Contractor or any dispute pending before any Court, Tribunal, Arbitrator or any other authority. We agree that the Guarantee herein contained shall be irrevocable and shall continue to be enforceable till the Employer discharges this guarantee. We further agree that no change in the constitution of the Bank or of the Employer shall affect this guarantee.

The Employer shall have the fullest liberty without affecting in any way the liability of the Bank under this guarantee, from time to time, to vary the advance or to extend the time for performance of the Contract by the Contractor. The Employer shall have the fullest liberty without affecting this guarantee, to postpone from time to time the exercise of any powers vested in them or of any right which they might have against the Contractor and to exercise the same at any time in any manner, and either to enforce or to for bear to enforce any covenants, contained or implied, in the Contract between the Employer and the Contractor or any other course or remedy or security available to the Employer. The bank shall not be released of its obligations under these presents by any exercise by the Employer of its liberty with reference to the matters aforesaid or any of them or by reason of any other act or forbearance or other acts of omission or commission on the part of the Employer or any other indulgence shown by the Employer or by any other matter or thing whatsoever which under law would but for this provision, have the effect of relieving the Bank.

The bank also agrees that the Employer at its option shall be entitled to enforce this Guarantee against the Bank as a principal debtor, in the first instance without proceeding against the Contractor and not withstanding any security or other guarantee that the Employer may have in relation to the Contractor's liabilities.

We the said bank do hereby declare and undertake that your claim under the guarantee shall not be affected by any deficiency or other defect in the powers of the bank or its officials and the guarantee

shall be deemed to have been issued as if the bank and its officials have all the powers and authorization to give this guarantee on behalf of the bank.

We the said bank does hereby certify the genuineness and appropriateness of the Stamp paper and stamp value used for issuing the guarantee. We the said bank do hereby declare and undertake that your claim under the guarantee shall not be affected by any deficiency or other defect in the stamp paper or its stamp value.

We the said bank do hereby declare that our payments hereunder shall be made to you , free and clear of and without and deduction, reduction on account of any reasons including any and all present and future taxes, levies, charges of withholding whatsoever imposed or collected with respect thereto.

Notwithstanding anything contained hereinabove our liability under this guarantee is limited to Rs. _____ (Rupees _____ only) and it shall remain in force upto and including _____ and shall be extended from time to time for such period (not exceeding one year), as may be desired by M/S _____ on whose behalf this bank guarantee has been given.

Notwithstanding anything contained herein

i) our liability under this guarantee shall not exceed Rs. _____ (Rupees _____ only);

ii) This bank guarantee shall be valid upto and till _____ only, being the date of expiry of the guarantee and

iii) We are liable to pay up to the guaranteed amount only and only if we receive from you a written claim or demand within the claim period not later than 12 months from the said expiry date relating to default that happened during the guarantee period and all your rights under this bank guarantee shall be extinguished and our liability under the bank guarantee shall stand discharged unless such written claim or demand is received by us from you on or before being the date of expiry of the guarantee

Dated this _____ day of _____ at Faridabad.

WITNESS

(Signature)

(Name)

(Official address)

(Signature)

(Name)

(Signature)

(Name)

(Designation with bank stamp)

Attorney as Power of Attorney

No. _____ dt. _____

SECTION- XIV
TENDER ACCEPTANCE LETTER
AND
INTEGRITY PACT

SECTION- XIV

TENDER ACCEPTANCE LETTER

From
{Name and Address of Tenderer}

Date

To
The Superintending Engineer
Central Ground Water Board
Bhujal Bhawan, NH-IV,
Faridabad, Pin-121001

Subject: Construction of Piezometer Wells in the U T Laddakh
Reference: Your Tender Enquiry Document No.{Number} dated {Date}
Dear sir,

1. I/ We have downloaded/ obtained the tender document(s) for the above mentioned 'Goods/Work' from <http://cgwb.gov.in> or the Central Public Procurement portal of Government of India <http://eprocure.gov.in/eprocure/app> as per your advertisement, given in the above mentioned websites.
2. I/ We hereby certify that I/ we have read the entire terms and conditions of the tender documents from Page No. _____ to _____ {including all documents like annexure(s), schedule(s), etcetera}, which form part of the contract agreement and I/ we shall abide by the terms/ conditions/ clauses contained therein.
3. The corrigendum(s) issued from time to time by your department/ organization too has also been taken into consideration, while submitting this acceptance letter.
4. I/ We hereby unconditionally accept the tender conditions of above mentioned tender document(s)/ corrigendum(s) in its totality / entirety.
5. I/ We hereby declare that our firm have never been under a declaration of non-eligibility for corrupt and fraudulent practices issued by any Court or Government Department or Public Sector Undertaking and not blacklisted for non-compliance of any contract by any Government Department or Public Sector Undertaking.
6. I / We certify that all information furnished by us is true and correct and in the event that the information is found to be untrue/ incorrect or found violated, then your department/ organization shall, without giving any notice or reason thereof, summarily reject the bid or terminate the contract, without prejudice to any other rights or remedy including the forfeiture of the earnest money deposited by us.

Yours faithfully,

(Signature of the Tenderer, with Official Seal)

INTEGRITY PACT

(To be signed on Plain Paper)
(To be submitted as part of Technical Bid)

**Integrity Pact for Tender Document No. _____, Tender No. _____, Tender Title:
Construction of Piezometer Wells in the UT of LADDAKH**

This Agreement (hereinafter called the Integrity Pact) is made on _____ day of the month of _____ 202__
at _____, India

BETWEEN

Procuring Organisation, ----- through Head of Procuring Organisation,
for and on behalf of President of India (hereinafter called the "The Principal", which expression shall mean
and include, unless the context otherwise requires, his successors in office and assigns) of the First Part
AND

M/ s. _____ (hereinafter called the "The Bidder/ Contractor" which
expression shall mean and include, unless the context otherwise requires, his successors and permitted
assigns) of the Second Part.

PREAMBLE

'The Principal' intends to award, under laid down organizational procedures, contract/ s for
_____, 'The Principal' values full compliance with all relevant laws of the land, rules,
regulations, economic use of resources and of fairness/ transparency in its relations with its Bidder(s) and/
or Contractor(s).

In order to achieve these goals, the Principal shall appoint Independent External Monitors (IEMs) who shall
monitor the tender process and the execution of the contract for compliance with the principles mentioned
above.

Section 1 - Commitments of the 'The Principal' 1.

1. 'The principal' commits itself to take all measures necessary to prevent corruption and to observe the following principles:
 - a. No employee of the principal, personally or through family members, shall in connection with the tender for, or the execution of a contract, demand, take a promise for or accept, for self or third person, any material or immaterial benefit which the person is not legally entitled to.
 - b. The principal shall, during the tender process treat all Bidder(s) with equity and reason. The principal shall in particular, before and during the tender process, provide to all Bidder(s) the same information and shall not provide to any Bidder(s) confidential/ additional information through which the Bidder(s) could obtain an advantage in relation to the tender process or the contract execution.
 - c. The Principal shall exclude from the process all known prejudiced persons.
2. If the Principal obtains information on the conduct of any of its employees which is a criminal offence under the IPC/ PC Act, or if there be a substantive suspicion in this regard, the Principal shall inform the Chief Vigilance Officer and in addition can initiate disciplinary actions.

Section 2 - Commitments of the 'Bidder/ Contractor'

1. The 'Bidder/ Contractor' commit themselves to take all measures necessary to prevent corruption. The 'Bidder/ Contractor' commit themselves to observe the following principles during participation in the tender process and during the contract execution.

a. The 'Bidder/ Contractor' shall not, directly or through any other person or firm, offer, promise, or give to any of the Principal's employees involved in the tender process or the execution of the contract or to any third person any material or other benefit which he/ she is not legally entitled to, in order to obtain in exchange any advantage of any kind whatsoever during the tender process or during the execution of the contract.

b. The 'Bidder/ Contractor' shall not enter with other Bidders into any undisclosed agreement or understanding, whether formal or informal. This applies in particular to prices, specifications, certifications, subsidiary contracts, submission or non-submission of bids or any other actions to restrict competitiveness or to introduce cartelization in the bidding process.

c. The 'Bidder/ Contractor' shall not commit any offence under the relevant IPC/ PC Act; further the 'Bidder/ Contractor' shall not use improperly, for purposes of competition or personal gain, or pass on to others, any information or document provided by the Principal as part of the business relationship, regarding plans, technical proposals, and business details, including information contained or transmitted electronically.

d. The 'Bidder/ Contractor' of foreign origin shall disclose the name and address of the Agents/ representatives in India, if any. Similarly, the Bidder/ Contractors of Indian Nationality shall furnish the name and address of the foreign principals, if any. Further details as mentioned in the "Guidelines on Indian Agents of Foreign Suppliers" shall be disclosed by the Bidder/ Contractor. Further, as mentioned in the Guidelines all the payments made to the Indian agent/ representative have to be in Indian Rupees only. Copy of the "Guidelines on Indian Agents of Foreign Suppliers" is placed at Annexe to this agreement.

e. The 'Bidder/ Contractor' shall, when presenting their bid, disclose any and all payments made, is committed to, or intends to make to agents, brokers, or any other intermediaries in connection with the award of the contract.

f. Bidder/ Contractor who have signed the Integrity Pact shall not approach the Courts while representing the matter to IEMs and shall wait for their decision in the matter.

2. The 'Bidder/ Contractor' shall not instigate third persons to commit offences outlined above or be an accessory to such offences.

Section 3 - Disqualification from tender process and exclusion from future contracts

If the 'Bidder/ Contractor', before award or during execution has committed a transgression through a violation of Section 2, above or in any other form such as to put their reliability or credibility in question, the Principal is entitled to disqualify the 'Bidder/ Contractor' from the tender process or take action as per the procedure mentioned in the "Guidelines on Banning of business dealings".

Section 4 - Compensation for Damages

1. If the Principal has disqualified the 'Bidder/ Contractor' from the tender process prior to the award according to Section 3, the Principal is entitled to demand and recover from 'Bidder/Contractor' the damages equivalent to Earnest Money Deposit/ Bid Security.

2. If the Principal has terminated the contract according to Section 3, or if the Principal is entitled to terminate the contract according to Section 3, the Principal shall be entitled to demand and recover from the Contractor liquidated damages of the Contract value or the amount equivalent to Performance Bank

Guarantee.

Section 5 - Previous transgression

1. The Bidder declares that no previous transgressions occurred in the last three years with any other Company in any country conforming to the anti-corruption approach or with any Public Sector Enterprise in India that could justify his exclusion from the tender process.

2. If the Bidder makes incorrect statement on this subject, he can be disqualified from the tender process or action can be taken as per the procedure mentioned in "Guidelines on Banning of business dealings".

Section 6 - Equal treatment of all Bidders/ Contractors/ Subcontractors

1 In case of Sub-contracting, the Principal Contractor shall take the responsibility of the adoption of Integrity Pact by the Sub-contractor.

2 The Principal shall enter into agreements with identical conditions as this one with all Bidders and Contractors.

3 The Principal shall disqualify from the tender process all bidders who do not sign this Pact or violate its provisions.

Section 7 - Criminal charges against violating Bidder(s)/ Contractor(s)/ Subcontractor(s)

If the Principal obtains knowledge of conduct of a Bidder, Contractor or Subcontractor, or of an employee or a representative or an associate of a Bidder, Contractor or Subcontractor which constitutes corruption, or if the principal has substantive suspicion in this regard, the principal shall inform the same to the Chief Vigilance Officer.

Section 8 - Independent External Monitor

1 The Principal appoints competent and credible Independent External Monitor for this Pact after approval by Central Vigilance Commission. The task of the Monitor is to review independently and objectively, whether and to what extent the parties comply with the obligations under this agreement.

2 The Monitor is not subject to instructions by the representatives of the parties and performs his/ her functions neutrally and independently. The Monitor would have access to all Contract documents, whenever required. It shall be obligatory for him/ her to treat the information and documents of the Bidders/ Contractors as confidential. He/ she reports to Head of Procuring Organization of Procuring Organization.

3 The Bidder(s)/ Contractor(s) accepts that the Monitor has the right to access without restriction to all Project documentation of the Principal including that provided by the Contractor. The Contractor shall also grant the Monitor, upon his/ her request and demonstration of a valid interest, unrestricted and unconditional access to their project documentation. The same is applicable to Sub-contractors.

4 The Monitor is under contractual obligation to treat the information and documents of the Bidder/ Contractor(s)/ Sub-contractor(s) with confidentiality. The Monitor has also signed declarations on 'Non-Disclosure of Confidential Information' and of 'Absence of Conflict of Interest'. In case of any conflict of interest arising at a later date, the IEM shall inform Head of Procuring Organization of Procuring Organization and recues himself/ herself from that case.

5. The Principal shall provide to the Monitor sufficient information about all meetings among the parties related to the Project provided such meetings could have an impact on the contractual relations between the Principal and the Contractor. The parties offer to the Monitor the option to participate in such meetings.

6. As soon as the Monitor notices, or believes to notice, a violation of this agreement, he/ she shall so inform the Management of the Principal and request the Management to discontinue or take corrective action, or to take other relevant action. The monitor can in this regard submit non-binding recommendations. Beyond this, the Monitor has no right to demand from the parties that they act in a specific manner, refrain from action, or tolerate action.

7. The Monitor shall submit a written report to Head of Procuring Organisation of Procuring Organisation within 8 to 10 weeks from the date of reference or intimation to him by the principal and, should the occasion arise, submit proposals for correcting problematic situations.

8. If the Monitor has reported to Head of Procuring Organisation of Procuring Organisation, a substantiated suspicion of an offence under relevant IPC/ PC Act, and Head of Procuring Organisation of Procuring Organisation has not, within the reasonable time taken visible action to proceed against such offence or reported it to the Chief Vigilance Officer, the Monitor may also transmit this information directly to the Central Vigilance Commissioner.

9. The word 'Monitor' would include both singular and plural.

Section 9 - Pact Duration

This Pact begins when both parties have legally signed it. It expires for the Contractor 12 months after the last payment under the contract, and for all other Bidders 6 months after the contract has been awarded. Any violation of the same would entail disqualification of the bidders and exclusion from future business dealings.

If any claim is made/ lodged during this time, the same shall be binding and continue to be valid despite the lapse of this pact as specified above, unless it is discharged/ determined by Head of Procuring Organisation of Procuring Organisation.

Section 10 - Other provisions

1 This agreement is subject to Indian Law. Place of performance and jurisdiction is the Registered Office of the Principal, i.e., Faridabad.

2 Changes and supplements as well as termination notices need to be made in writing. Side agreements have not been made.

3 If the Contractor is a partnership or a consortium, this agreement must be signed by all partners or consortium members.

4 Should one or several provisions of this agreement turn out to be invalid, the remainder of this agreement remains valid. In this case, the parties shall strive to come to an agreement to their original intentions.

5 Issues like Warranty/ Guarantee etc. shall be outside the purview of IEMs.

6 In the event of any contradiction between the Integrity Pact and its Annexure, the Clause in the Integrity Pact shall prevail.

For and on behalf of the principal

(Name of the Officer and Designation)

(Office Seal)

For and on behalf of 'Bidder/ Contractor'

(Name of the Officer and Designation)

(Office Seal)

For and on Behalf of the Principal

Place

Date

Witness 1:

(Name & Address)

Witness 2:

(Name & Address)

Date:

Annexe to Integrity Pact

Guidelines for Indian Agents of Foreign Bidders

1.0 There shall be compulsory registration of agents for all Global (Open) Tender and Limited Tender. An agent who is not registered with 'The Principal' shall apply for registration in the registration form with appropriate unit.

1.1 Registered agents shall file an authenticated Photostat copy duly attested by a Notary Public/ Original certificate of the Principal confirming the agency agreement. It should cover - the precise relationship, services to be rendered, mutual interests in business - generally and/ or specifically for the tender. Any commission/ remuneration/ salary/ retainer ship, which the agent or associate receives in India or abroad from the OEM, whether should be brought on record in the Agreement and be made explicit.

1.2 Wherever the Indian representatives have communicated on behalf of their principals and the foreign parties have stated that they are not paying any commission to the Indian agents, and the Indian representative is working on the basis of salary or as retainer, a written declaration to this effect should be submitted by the party (i.e., Principal) before finalizing the order.

2.0 Disclosure of particulars of agents/ representatives in India, if any.

2.1 Bidders of Foreign nationality shall furnish the following details in their offers:

2.1.1 The 'Bidder/ Contractor' of foreign origin shall disclose the name and address of the agents/ representatives in India if any and the extent of authorization and authority given to commit the Principals. In case the agent/ representative be a foreign Company, it shall be confirmed whether it is existing Company and details of the same shall be furnished.

2.1.2 The amount of commission/ remuneration included in the quoted price(s) for such agents/ representatives in India.

2.1.3 Confirmation of the Bidder that the commission/ remuneration, if any, payable to his agents/ representatives in India, may be paid by 'The Principal' in Indian Rupees only.

2.2 Bidders of Indian Nationality shall furnish the following details in their offers:

2.2.1 The 'Bidder/ Contractor' of Indian Nationality shall furnish the name and address of the foreign principals, if any, indicating their nationality as well as their status, i.e., whether manufacturer or agents of manufacturer holding the Letter of Authority of the Principal specifically authorizing the agent to make an offer in India in response to tender either directly or through the agents/ representatives.

2.2.2 The amount of commission/ remuneration included in the price (s) quoted by the Bidder for himself.

2.2.3 Confirmation of the foreign principals of the Bidder that the commission/ remuneration, if any, reserved for the Bidder in the quoted price(s), may be paid by 'The Principal' in India in equivalent Indian Rupees on satisfactory completion of the Project or supplies of Stores and Spares in case of operation items.

2.3 In either case, in the event of contract materializing, the terms of payment shall provide for payment of the commission/ remuneration, if any payable to the agents/ representatives in India in Indian Rupees on expiry of 90 days after the discharge of the obligations under the contract.

2.4 Failure to furnish correct and detailed information as called for in clauses above shall render the concerned tender liable to rejection or in the event of a contract materializing, the same liable to termination by 'The Principal'. Besides this there would be a penalty of banning business dealings with 'The Principal' or damage or payment of a named sum.

SECTION- XV
INSTRUCTIONS
FOR
ONLINE BID SUBMISSION

	SECTION- XV
	INSTRUCTIONS FOR ONLINE SUBMISSION OF BIDS
	<p>The bidders are required to submit soft copies of their bids electronically on the CPP Portal, using valid Digital Signature Certificates. The instructions given below are meant to assist the bidders in registering on the CPP Portal, prepare their bids in accordance with the requirements and submitting their bids online on the CPP Portal.</p> <p>More information useful for submitting online bids on the CPP Portal may be obtained at: https://eprocure.gov.in/eprocure/app.</p> <p>REGISTRATION</p> <ol style="list-style-type: none"> 1) Bidders are required to enroll on the e-Procurement module of the Central Public Procurement Portal (URL: https://eprocure.gov.in/eprocure/app) by clicking on the link “Online bidder Enrollment” on the CPP Portal which is free of charge. 2) As part of the enrolment process, the bidders will be required to choose a unique username and assign a password for their accounts. 3) Bidders are advised to register their valid email address and mobile numbers as part of the registration process. These would be used for any communication from the CPP Portal. 4) Upon enrolment, the bidders will be required to register their valid Digital Signature Certificate (Class II or Class III Certificates with signing key usage) issued by any Certifying Authority recognized by CCA India (e.g. Sify / TCS / nCode / eMudhra etc.), with their profile. 5) Only one valid DSC should be registered by a bidder. Please note that the bidders are responsible to ensure that they do not lend their DSC’s to others which may lead to misuse. 6) Bidder then logs in to the site through the secured log-in by entering their user ID / password and the password of the DSC / e-Token. <p>SEARCHING FOR TENDER DOCUMENTS</p> <ol style="list-style-type: none"> 1) There are various search options built in the CPP Portal, to facilitate bidders to search active tenders by several parameters. These parameters could include Tender ID, Organization Name, Location, Date, Value, etc. There is also an option of advanced search for tenders, wherein the bidders may combine a number of search parameters such as Organization Name, Form of Contract, Location, Date, Other keywords etc. to search for a tender published on the CPP Portal. 2) Once the bidders have selected the tenders they are interested in, they may download the required documents / tender schedules. These tenders can be moved to the respective ‘My Tenders’ folder. This would enable the CPP Portal to intimate the bidders through SMS / e-mail in case there is any corrigendum issued to the tender document. 3) The bidder should make a note of the unique Tender ID assigned to each tender, in

case they want to obtain any clarification / help from the Helpdesk.

PREPARATION OF BIDS

- 1) Bidder should take into account any corrigendum published on the tender document before submitting their bids.
- 2) Please go through the tender advertisement and the tender document carefully to understand the documents required to be submitted as part of the bid. Please note the number of covers in which the bid documents have to be submitted, the number of documents - including the names and content of each of the document that need to be submitted. Any deviations from these may lead to rejection of the bid.
- 3) Bidder, in advance, should get ready the bid documents to be submitted as indicated in the tender document / schedule and generally, they can be in PDF / XLS / RAR / DWF/JPG formats. Bid documents may be scanned with 100 dpi with black and white option which helps in reducing size of the scanned document.
- 4) To avoid the time and effort required in uploading the same set of standard documents which are required to be submitted as a part of every bid, a provision of uploading such standard documents (e.g. PAN card copy, annual reports, auditor certificates etc.) has been provided to the bidders. Bidders can use "My Space" or "Other Important Documents" area available to them to upload such documents. These documents may be directly submitted from the "My Space" area while submitting a bid, and need not be uploaded again and again. This will lead to a reduction in the time required for bid submission process.

SUBMISSION OF BIDS

- 1) Bidder should log into the site well in advance for bid submission so that they can upload the bid in time i.e. on or before the bid submission time. Bidder will be responsible for any delay due to other issues.
- 2) The bidder has to digitally sign and upload the required bid documents one by one as indicated in the tender document.
- 3) Bidder has to select the payment option as "offline" to pay the tender fee / EMD as applicable and enter details of the instrument.
- 4) Bidder should prepare the EMD as per the instructions specified in the tender document. The original should be posted/couriered /given in person to the concerned official, latest by the last date of bid submission or as specified in the tender documents. The details of the DD/any other accepted instrument, physically sent, should tally with the details available in the scanned copy and the data entered during bid submission time. Otherwise the uploaded bid will be rejected.
- 5) Bidders are requested to note that they should necessarily submit their financial bids in the format provided and no other format is acceptable. If the price bid has been given as a standard BoQ format with the tender document, then the same is to be downloaded and to be filled by all the bidders. Bidders are required to download the BoQ file, open it and complete the white colored (unprotected) cells with their respective financial quotes and other details (such as name of the bidder). No other cells should be changed. Once the details have been completed, the bidder should save it and submit it online, without changing the filename. If the BoQ file is found to be

modified by the bidder, the bid will be rejected.

- 6) The server time (which is displayed on the bidders' dashboard) will be considered as the standard time for referencing the deadlines for submission of the bids by the bidders, opening of bids etc. The bidders should follow this time during bid submission.
- 7) All the documents being submitted by the bidders would be encrypted using PKI encryption techniques to ensure the secrecy of the data. The data entered cannot be viewed by unauthorized persons until the time of bid opening. The confidentiality of the bids is maintained using the secured Socket Layer 128 bit encryption technology. Data storage encryption of sensitive fields is done. Any bid document that is uploaded to the server is subjected to symmetric encryption using a system generated symmetric key. Further this key is subjected to asymmetric encryption using buyers/bid opener's public keys. Overall, the uploaded tender documents become readable only after the tender opening by the authorized bid openers.
- 7) The uploaded tender documents become readable only after the tender opening by the authorized bid openers.
- 8) Upon the successful and timely submission of bids (i.e. after Clicking "Freeze Bid Submission" in the portal), the portal will give a successful bid submission message and a bid summary will be displayed with the bid no. and the date and time of submission of the bid with all other relevant details.
- 9) The bid summary has to be printed and kept as an acknowledgement of the submission of the bid. This acknowledgement may be used as an entry pass for any bid opening meetings.

ASSISTANCE TO BIDDERS

- 1) Any queries relating to the tender document and the terms and conditions contained therein should be addressed to the Tender Inviting Authority or the relevant contact person indicated in the tender.
- 2) Any queries relating to the process of online bid submission or queries relating to CPP Portal in general may be directed to the 24x7 CPP Portal Helpdesk. The contact number for the helpdesk is Toll Free No. 1800 3070 2232 and Mobile Nos 91 7878007972 and 91 7878007973.

SECTION-XVI

SAFETY CODE

SECTION-XVI

SAFETY CODE

1. Suitable scaffolds should be provided for workmen for all works that cannot safely be done from the ground, or from solid construction except such short period work as can be done safely from ladders. When a ladder is used, an extra mazdoor shall be engaged for holding the ladder and if the ladder is used for carrying materials as well suitable footholds and hand-hold shall be provided on the ladder and the ladder shall be given an inclination not steeper than $\frac{1}{4}$ to 1($\frac{1}{4}$ horizontal and 1 vertical.)
2. Scaffolding of staging more than 3.6 m (12ft.) above the ground or floor, swung or suspended from an overhead support or erected with stationary support shall have a guard rail properly attached or bolted, braced and otherwise secured at least 90 cm. (3ft.) high above the floor or platform of such scaffolding or staging and extending along the entire length of the outside and ends there of with only such opening as may be necessary for the delivery of materials. Such scaffolding or staging shall be so fastened as to prevent it from swaying from the building or structure.
3. Working platforms, gangways and stairways should be so constructed that they should not sag unduly or unequally, and if the height of the platform or the gangway or the stairway is more than 3.6 m (12ft.) above ground level or floor level, they should be closely boarded, should have adequate width and should be suitably fastened as described in (2) above.
4. Every opening in the floor of a building or in a working platform shall be provided with suitable means to prevent the fall of person or materials by providing suitable fencing or railing whose minimum height shall be 90 cm. (3ft.)
5. Safe means of access shall be provided to all working platforms and other working places. Every ladder shall be securely fixed. No portable single ladder shall be over 9m. (30ft.) in length while the width between side rails in rung ladder shall in no case be less than 29 cm. (11 $\frac{1}{2}$ ") for ladder upto and including 3 m. (10 ft.) in length. For longer ladders, this width should be increased at least $\frac{1}{4}$ " for each additional 30 cm. (1 foot) of length. Uniform step spacing of not more than 30 cm shall be kept. Adequate precautions shall be taken to prevent danger from electrical equipment. No materials on any of the sites or work shall be so stacked or placed as to cause danger or inconvenience to any person or the public. The contractor shall provide all necessary fencing and lights to protect the public from accident and shall be bound to bear the expenses of defence of every suit, action or other proceedings at law that may be brought by any person for injury sustained owing to neglect of the above precautions and to pay any damages and cost which may be awarded in any such suit, action or proceedings to any such person or which may, with the consent of the contractor, be paid to compensate any claim by any such person.
6. Excavation and Trenching - All trenches 1.2 m. (4ft.) or more in depth, shall at all times be supplied with at least one ladder for each 30 m. (100 ft.) in length or fraction thereof Ladder shall extend from bottom of the trench to at least 90 cm. (3ft.) above the surface of the ground. The side of the trenches which are

1.5 m. (5ft.) or more in depth shall be stepped back to give suitable slope or securely held by timber bracing, so as to avoid the danger of sides collapsing. The excavated materials shall not be placed within

1.5m. (5ft.) of the edges of the trench or half of the depth of the trench whichever is more. Cutting shall be done from top to bottom. Under no circumstances undermining or undercutting shall be done.

7. Demolition - Before any demolition work is commenced and also during the progress of the work,
 - i) All roads and open areas adjacent to the work site shall either be closed or suitably protected
 - ii) No electric cable or apparatus which is liable to be a source of danger or a cable or apparatus used by the operator shall remain electrically charged.
 - ii) All practical steps shall be taken to prevent danger to persons employed from risk of fire or explosion or flooding. No floor, roof or other part of the building shall be so overloaded with debris or materials as to render it unsafe.
8. All necessary personal safety equipment as considered adequate by the Employer should be kept available for the use of the person employed on the site and maintained in a condition suitable for immediate use, and the contractor should take adequate steps to ensure proper use of equipment by those concerned:- The following safety equipment shall invariably be provided.
 - i) Workers employed on mixing asphaltic materials, cement and lime mortars shall be provided with protective footwear and protective goggles.
 - ii) Those engaged in white washing and mixing or stacking of cement bags or any material which is injurious to the eyes, shall be provided with protective goggles.
 - iii) Those engaged in welding works shall be provided with welder's protective eye-shields.
 - iv) Stone breaker shall be provided with protective goggles and protective clothing and seated at sufficiently safe intervals.
 - v) When workers are employed in sewers and manholes, which are in active use, the contractors shall ensure that the manhole covers are opened and ventilated at least for an hour before the workers are allowed to get into the manholes, and the manholes so opened shall be cordoned off with suitable railing and provided with warning signals or boards to prevent accident to the public. In addition, the contractor shall ensure that the following safety measure are adhered to :-
 - a) Entry for workers into the line shall not be allowed except under supervision of the JE or any other higher officer.
 - b) At least 5 to 6 manholes upstream and downstream should be kept open for at least 2 to 3 hours before any man is allowed to enter into the manhole for working inside.
 - c) Before entry presence of Toxic gases should be tested by inserting wet lead acetate paper which changes colour in the presence of such gases and gives indication of their presence.
 - d) Presence of Oxygen should be verified by lowering a detector lamp into the manhole. In case, no Oxygen is found inside the sewer line, workers should be sent only with

Oxygen kit.

- e) Safety belt with rope should be provided to the workers. While working inside the manholes such rope should be handled by two men standing outside to enable him to be pulled out during emergency.
- f) The area should be barricaded or cordoned off by suitable means to avoid mishaps of any kind. Proper warning signs should be displayed for the safety of the public whenever cleaning works are undertaken during night or day.
- g) No smoking or open flames shall be allowed near the blocked manhole being cleaned.
- h) The malba obtained on account of cleaning of blocked manholes and sewer lines should be immediately removed to avoid accidents on account of slippery nature of the malba.
- i) Workers should not be allowed to work inside the manhole continuously. He should be given rest intermittently. The Employer may decide the time up to which a worker may be allowed to work continuously inside the manhole.
- j) Gas masks with Oxygen Cylinder should be kept at site for use in emergency.
- k) Air-blowers should be used for flow of fresh air through the manholes. Whenever called for portable air blowers are recommended for ventilating the manholes. The Motors for these shall be vapour proof and of totally enclosed type. Non sparking gas engines also could be used but they should be placed at least 2 metres away from the opening and on the leeward side protected from wind so that they will not be a source of friction on any inflammable gas that might be present.
- l) The workers engaged for cleaning the manholes/sewers should be properly trained before allowing to work in the manhole.
- m) The workers shall be provided with Gumboots or non sparking shoes bump helmets and gloves non sparking tools safety lights and gas masks and portable air blowers (when necessary). They must be supplied with barrier cream for anointing the limbs before working inside the sewer lines.
- n) Workmen descending a manhole shall try each ladder stop or rung carefully before putting his full weight on it to guard against insecure fastening due to corrosion of the rung fixed to manhole well.
- o) If a man has received a physical injury, he should be brought out of the sewer immediately and adequate medical aid should be provided to him.
- p) The extent to which these precautions are to be taken depend on individual situation but the decision of the Employer regarding the steps to be taken in this regard in an individual case will be final.
- vi) The Contractor shall not employ men and women below the age of 18 years on the work of painting with products containing lead in any form. Wherever men above the age of 18 are employed on the work of lead painting, the following precaution should be taken:-
 - a) No paint containing lead or lead products shall be used except in the form of paste or ready made paint.
 - b) Suitable face masks should be supplied for use by the workers when paint is applied in the form of spray or a surface having lead paint is dry rubbed and scraped.

- c) Overalls shall be supplied by the contractors to the workmen and adequate facilities shall be provided to enable the working painters to wash during and on the cessation of work.
- 9 The Contractor shall not employ women and men below the age of 18 on the work of painting with product containing lead in any form. wherever men above the age of 18 are employed on the work of lead painting, the following principles must be observed for such use :
- (i) White lead, sulphate of lead or product containing these pigment, shall not be used in painting operation except in the form of pastes or paint ready for use.
 - ii) Measures shall be taken, wherever required in order to prevent danger arising from the application of paint in the form of spray.
 - iii) Measures shall be taken, wherever practicable, to prevent danger arising out of from dust caused by dry rubbing down and scraping.
 - iv) Adequate facilities shall be provided to enable working painters to wash during and on cessation of work.
 - v) Overall shall be worn by working painters during the whole of working period.
 - vi) Suitable arrangement shall be made to prevent clothing put off during working hours being spoiled by painting materials.
 - vii) Cases of lead poisoning and suspected lead poisoning shall be notified and shall be subsequently verified by medical man appointed by the Employer.
 - viii) The Employer may require, when necessary medical examination of workers.
 - ix) Instructions with regard to special hygienic precautions to be taken in the painting trade shall be distributed to working painters.
10. When the work is done near any place where there is risk of drowning, all necessary equipments should be provided and kept ready for use and all necessary steps taken for prompt rescue of any person in danger and adequate provision, should be made for prompt first aid treatment of all injuries likely to be obtained during the course of the work.
11. Use of hoisting machines and tackle including their attachments, anchorage and supports shall conform to the following standards or conditions :-
- i) (a) These shall be of good mechanical construction, sound materials and adequate strength and free from patent defects and shall be kept repaired and in good working order.
 - (b) Every rope used in hoisting or lowering materials or as a means of suspension shall be of durable quality and adequate strength, and free from patent defects.
 - ii) Every crane driver or hoisting appliance operator, shall be properly qualified and no person under the age of 21 years should be in charge of any hoisting machine including any scaffolding winch or give signals to operator.
 - iii) In case of every hoisting machine and of every chain ring hook, shackle swivel and pulley block used in hoisting or as means of suspension, the safe working load shall be ascertained by adequate means. Every hoisting machine and all gear referred to above shall be plainly marked with the safe working load. In case of a hoisting machine having a variable safe working load each safe working load and the condition under which it is applicable shall be clearly indicated. No part of any machine or any gear referred to

above in this paragraph shall be loaded beyond the safe working load except for the purpose of testing.

- iv) In case of departmental machines, the safe working load shall be notified by the Electrical Employer. As regards contractor's machines the contractors shall notify the safe working load of the machine to the Employer whenever he brings any machinery to site of work and get it verified by the Electrical Engineer concerned.
12. Motors, gearing, transmission, electric wiring and other dangerous parts of hoisting appliances should be provided with efficient safeguards. Hoisting appliances should be provided with such means as will reduce to the minimum the risk of accidental descent of the load. Adequate precautions should be taken to reduce to the minimum the risk of any part of a suspended load becoming accidentally displaced. When workers are employed on electrical installations which are already energized, insulating mats, wearing apparel, such as gloves, sleeves and boots as may be necessary should be provided. The worker should not wear any rings, watches and carry keys or other materials which are good conductors of electricity.
 13. All scaffolds, ladders and other safety devices mentioned or described herein shall be maintained in safe condition and no scaffold, ladder or equipment shall be altered or removed while it is in use. Adequate washing facilities should be provided at or near places of work.
 14. These safety provisions should be brought to the notice of all concerned by display on a notice board at a prominent place at work spot. The person responsible for compliance of the safety code shall be named therein by the contractor.
 15. To ensure effective enforcement of the rules and regulations relating to safety precautions the arrangements made by the contractor shall be open to inspection by the Labour Officer or Employer of the department or their representatives.
 1. Notwithstanding the above clauses from (1) to (15) there is nothing in these to exempt the contractor from the operations of any other Act or Rule in force in the Republic of India.

WP(C) 36/2009

ITEM NO.11

COURT NO.1

SECTION PIL

S U P R E M E C O U R T O F I N D I A
R E C O R D O F P R O C E E D I N G S

WRIT PETITION (CIVIL) NO(s). 36 OF 2009

IN RE: MEASURES FOR PREVENTION OF FATAL
ACCIDENTS OF SMALL CHILDREN DUE TO THEIR
FALLING INTO ABANDONED BORE WELLS AND TUBE WELLS

Petitioner(s)

VERSUS

UNION OF INDIA & ORS.

Respondent(s)

(With office report)

Date: 11/02/2010

This Petition was called on for hearing today.

CORAM :

HON'BLE THE CHIEF JUSTICE
HON'BLE DR. JUSTICE B.S. CHAUHAN
HON'BLE MR. JUSTICE C.K. PRASAD

Mr. Paramjit Singh Patwalia, Sr. Adv.

(A.C.)

For Petitioner(s)

For Respondent(s)

Ms. Indira JaiSing, ASG
Mr. Ashok Bhan, Adv.
Ms. Sadhna Sandhu, Adv.
Mr. C.K. Sharma, Adv.
Mr. D.S. Mahra, Adv.

For State of Haryana

Mr. Manjit Singh, AAG for Haryana
Mr. Kamal Mohan Gupta, Adv.
Ms.Reeta Chaudhary, Adv.
Mr. Gaurav Teotia,Adv.

For State of Punjab

Mrs. JayshreeAnand, AAG for Punjab
Mr. K.K. Mahalik, Adv.
Mrs. Noor Jahan, Adv.
Mr. Kuldip Singh, Adv.

For State of Raj.

Dr. Manish Singhvi, AAG for Rajasthan
Mr. Devanshu Kumar Devesh, Adv.
Mr. Milind Kumar, Adv.
Mr. T. Harish Kumar, Adv.

For State of U.P.

Mr. Shail Kumar Dwivedi, AAG for U.P.
Mr. Manoj Kr. Dwivedi, adv.
Ms. Vandana Mishra, Adv.
Mr. Ashutosh Kr. Sharma, Adv.
Mr. GunnamVenkateswara Rao, Adv.

For State of T.N.

Ms. Promila, adv.
Mr. S. Thananjayan, Adv.

UPON hearing counsel the Court made the following O R D E R

Certain safety measures/guidelines have been given in the signed order which are to be observed by all the States. The guidelines given in the signed order Shall be given wide publicity through the national television channels. A copy of this order be sent to the Chief Secretaries of all the States/Union Territories who shall forward the same to the District Collectors of all Districts of their respective State.

For further directions post this matter after 12 weeks.

(Ajay Kr. Jain)
Court Master

(Veera Verma)
Court Master

(Signed order is placed on the file)

IN THE SUPREME COURT OF INDIA
CIVIL ORIGINAL JURISDICTION

WRIT PETITION(C)NO.36 OF 2009

In Re: Measures for Prevention of Fatal Accidents of Small Children Due to Their Falling Into Abandoned Bore Wells and Tube Wells	Petitioner
	Versus	
Union of India &Ors.	Respondents

ORDER

Heard the learned Amicus Curiae and the learned Addl. Solicitor General appearing for the Union of India.

It has been brought to the notice of this Court that in a number of cases children had been trapped and fallen into bore wells and tube wells or abandoned wells. These reports have been coming from various States. Accordingly, we took suomotu initiative and issued notice to the various States to take immediate measures to prevent such kind of incidents.

The Union of India has filed its counter affidavit giving certain guidelines to be followed by the States.

We have perused the affidavit and the guidelines suggested by the Union of India.

Having regard to the number of incidents that have taken place during the recent past and immediate need for preventing such incidents in future, we direct that the following safety measures/guidelines are to be observed by all the States :-

(i)"The owner of the land/premises, before taking any steps for constructing bore well/ tube well must inform in writing at least 15 days in advance to the concerned authorities in the area, i.e., District Collector/ District Magistrate/Sarpanch of the Gram Panchayat/ concerned officers of the Department of Ground Water/ Public Health/ Municipal Corporation, as the case may be, about the construction of bore well/tube well.

(ii)Registration of all the drilling agencies,viz., Govt./Semi Govt./Private etc. should be mandatory with the district administration.

(iii)Erection of signboard at the time of construction near the well with the following details :-

a)Complete address of the drilling agency at the time of construction/
rehabilitation of well. (b)Complete address of the user agency/ owner
ofthe well.

(iv)Erection of barbed wire fencing or any other suitable barrier around the well during construction.

(v)Construction of cement/concrete platform measuring 0.50 x 0.50x 0.60 meter (0.30 meter above ground level and 0.30 meter below ground level) around the well casing.

(vi)Capping of well assembly by welding steel plate or by providing a strong cap to be fixed to the casing pipe with bolts & nuts.

(vii)In case of pump repair, the tube well should not be left uncovered.

(viii)Filling of mud pits and channels after completion of works.

(ix)Filling up abandoned borewells by clay/sand /boulders/pebbles/drill cuttings etc. from bottom to ground level.

(x)On completion of the drilling operations at a particular location, the ground conditions are to be restored as before the start of drilling.

(xi)District Collector should be empowered to verify that the above guidelines are being followed and proper monitoring check about the status of boreholes/tubewells are being taken care through the concerned State/Central Government agencies.

(xii)District/Block/Village wise status of bore wells/tubewells drilled viz. No. of wells in use, No.of abandoned bore wells/tube wells found open, No. of abandoned borewells/tubewells properly filled up to ground level and balance number of abandoned borewells/tubewells to be filled up to ground level is to be maintained at District Level.

In rural areas, the monitoring of the above is to be done through Village Sarpanch and the Executive from the Agriculture Department.

In case of urban areas, the monitoring of the above is to be done through Junior Engineer and the Executive from the concerned Department of Ground Water/Public Health/ Municipal Corporation etc.

(xiii)If a borewell/tubewell is 'Abandoned' at any stage, a certificate from the concerned department of Ground Water/Public health/Municipal Corporation/Private contractor etc. must be obtained by the aforesaid agencies that the 'Abandoned' borewell/tubewell is properly filled upto the ground level. Random inspection of the abandoned wells is also to be done by the Executive of the concern agency/department. Information on all such data on the above are to be maintained in the District Collector/ Block Development Office of the State.

The guidelines abovementioned shall be given wide publicity through the national television channels. A copy of this order be sent to the Chief Secretaries of all the States/Union Territories who shall forward thesame to the District Collectors of all Districts of their respective State for further directions post this matter after 12 weeks.

.....CJI.

.....J.
(Dr. B.S. CHAUHAN)

.....J. (C.K. PRASAD)

NEW DELHI;
FEBRUARY 11, 2010

SECTION- XVII

MODEL RULES FOR THE PROTECTION OF HEALTH AND SANITARY ARRANGEMENTS FOR WORKERS

SECTION- XVII

MODEL RULES FOR THE PROTECTION OF HEALTH AND SANITARY ARRANGEMENTS FOR WORKERS

1. APPLICATION

These rules shall apply to all buildings and construction works in which twenty or more workers are ordinarily employed or are proposed to be employed in any day during the period during which the contract work is in progress.

2. DEFINITION

Work place means a place where twenty or more workers are ordinarily employed in connection with construction work on any day during the period during which the contract work is in progress.

3. FIRST-AID FACILITIES

- i) At every work place there shall be provided and maintained, so as to be easily accessible during working hours, first-aid boxes at the rate of not less than one box for 150 contract labour or part thereof ordinarily employed.
- ii) The first-aid box shall be distinctly marked with a red cross on white back ground and shall contain the following equipment:-
 - a) For work places in which the number of contract labour employed does not exceed 50-Each first-aid box shall contain the following equipments :-
 1. 6 small sterilized dressings.
 2. 3 medium size sterilized dressings.
 3. 3 large size sterilized dressings.
 4. 3 large sterilized burn dressings.
 5. 1 (30 ml.) bottle containing a two per cent alcoholic solution of iodine.
 6. 1 (30 ml.) bottle containing salvolatile having the dose and mode of administration indicated on the label.
 7. 1 snakebite lancet.
 8. 1 (30 gms.) bottle of potassium permanganate crystals.
 9. 1 pair scissors.
 10. 1 copy of the first-aid leaflet issued by the Director General, Factory Advice Service and Labour Institutes, Government of India.
 11. 1 bottle containing 100 tablets (each of 5 gms.) of aspirin.
 12. Ointment for burns.
 13. A bottle of suitable surgical antiseptic solution.
 - b) For work places in which the number of contract labour

exceed 50. Each first-aid box shall contain the following equipments.

1. 12 small sterilized dressings.
 2. 6 medium size sterilized dressings.
 3. 6 large size sterilized dressings.
 4. (15 gms.) Packets sterilized cotton wool.
 5. 1 (60 ml.) bottle containing two per cent alcoholic solution iodine.
 6. 1 (60 ml.) bottle containing salvolatile having the dose and mode of administration indicated on the label.
 7. 1 rolls of adhesive plaster.
 8. 1 snake bite lancet.
 9. 1 (30 gms.) bottle of potassium permanganate crystals.
 10. 1 pair scissors.
 11. 1 copy of the first-aid leaflet issued by the Director General Factory Advice Service and Labour Institutes /Government of India.
 12. A bottle containing 100 tablets (each of 5 gms.) of aspirin.
 13. Ointment for burns.
 14. A bottle of suitable surgical antiseptic solution.
- iii) Adequate arrangements shall be made for immediate recoument of the equipment when necessary.
- iv) Nothing except the prescribed contents shall be kept in the First-aid box.
- v) The first-aid box shall be kept in charge of a responsible person who shall always be readily available during the working hours of the work place.
- vi) A person in charge of the First-aid box shall be a person trained in First-aid treatment, in the work places where the number of contract labour employed is 150 or more.
- vii) In work places where the number of contract labour employed is 500 or more and hospital facilities are not available within easy distance from the works. First-aid posts shall be established and run by a trained compounder. The compounder shall be on duty and shall be available at all hours when the workers are at work.
- viii) Where work places are situated in places which are not towns or cities, a suitable motor transport shall be kept readily available to carry injured person or person suddenly taken ill to the nearest hospital.

4. DRINKING WATER

- i) In every work place, there shall be provided and maintained at suitable places, easily accessible to labour, a sufficient supply of cold water fit for drinking.
- ii) Where drinking water is obtained from an Intermittent public water supply, each work place shall be provided with storage where such drinking water shall be stored.

- iii) Every water supply or storage shall be at a distance of not less than 50 feet from any latrine drain or other source of pollution. Where water has to be drawn from an existing well which is within such proximity of latrine, drain or any other source of pollution, the well shall be properly chlorinated before water is drawn from it for drinking. All such wells shall be entirely closed in and be provided with a trap door which shall be dust and waterproof.
- iv) A reliable pump shall be fitted to each covered well, the trap door shall be kept locked and opened only for cleaning or inspection which shall be done at least once a month.

5. WASHING FACILITIES

- i) In every work place adequate and suitable facilities for washing shall be provided and maintained for the use of contract labour employed therein.
- ii) Separate and adequate cleaning facilities shall be provided for the use of male and female workers.
- iii) Such facilities shall be conveniently accessible and shall be kept in clean and hygienic condition.

6. LATRINES AND URINALS

- i) Latrines shall be provided in every work place on the following scale namely :-
 - a) Where female are employed there shall be at least one latrine for every 25 females.
 - b) Where males are employed, there shall be at least one latrine for every 25 males.

Provided that where the number of males or females exceeds 100, it shall be sufficient if there is one latrine for 25 males or females as the case may be up to the first 100, and one for every 50 thereafter.
- ii) Every latrine shall be under cover and so partitioned off as to secure privacy, and shall have a proper door and fastenings.
- iii) Construction of latrines : The inside walls shall be constructed of masonry or some suitable heat-resisting nonabsorbent materials and shall be cement washed inside and outside at least once a year, Latrines shall not be of a standard lower than borehole system.
- iv) a) Where workers of both sexes are employed, there shall be displayed outside each block of
 - latrine and urinal, a notice in the language understood by the majority of the workers "For Men only" or "For Women Only" as the case may be.
 - b) The notice shall also bear the figure of a man or of a woman, as the case may be.
- v) There shall be at least one urinal for male workers up to 50 and one for female workers up to fifty employed at a time, provided that where the number of male or female workmen, as the case may be exceeds 500, it shall be sufficient if there is one urinal for every 50 males or females up to the first 500 and one for every 100 or

part thereafter.

- vi) a) The latrines and urinals shall be adequately lighted and shall be maintained in a clean and sanitary condition at all times.
b) Latrines and urinals other than those connected with a flush sewage system shall comply with the requirements of the Public Health Authorities.
- vii) Water shall be provided by means of tap or otherwise so as to be conveniently accessible in or near the latrines and urinals.
- viii) Disposal of excreta :- Unless otherwise arranged for by the local sanitary authority, arrangements for proper disposal of excreta by incineration at the work place shall be made by means of a suitable incinerator. Alternately excreta may be disposed of by putting a layer of night soil at the bottom of a pucca tank prepared for the purpose and covering it with a 15 cm. layer of waste or refuse and then covering it with a layer of earth for a fortnight (when it will turn to manure).
- (ix) The contractor shall at his own expense, carry out all instructions issued to him by the Employer to effect proper disposal of night soil and other conservancy work in respect of the contractor's workmen or employees on the site. The contractor shall be responsible for payment of any charges which may be levied by Municipal or Cantonment Authority for execution of such on his behalf.

7. PROVISION OF SHELTER DURING REST

At every place there shall be provided, free of cost, four suitable sheds, two for meals and the other two for rest separately for the use of men and women labour. The height of each shelter shall not be less than 3 metres (10 ft.) from the floor level to the lowest part of the roof. These shall be kept clean and the space provided shall be on the basis of 0.6 sq.m. (6 sft) per head.

Provided that the Employer may permit subject to his satisfaction, a portion of the building under construction or other alternative accommodation to be used for the purpose.

8. CRECHES

- i) At every work place, at which 20 or more women worker are ordinarily employed, there shall be provided two rooms of reasonable dimensions for the use of their children under the age of six years. One room shall be used as a play room for the children and the other as their bedroom.
- ii) The rooms shall be provided with suitable and sufficient openings for light and ventilation. There shall be adequate provision of sweepers to keep the places clean.
- iii) The contractor shall supply adequate number of toys and games in the play room and sufficient number of cots and beddings in the bed room.
- iv) The contractor shall provide one ayaa to look after the children in the creche when the number of women workers does not exceed 50 and two when the number of women workers exceed 50.
- v) The use of the rooms earmarked as creches shall be restricted to children, their attendants and mothers of the children.

9. CANTEENS

- i) In every work place where the work regarding the employment of contract labour is likely to continue for six months and where in contract labour numbering one hundred or more are ordinarily employed, an adequate canteen shall be provided by the contractor for the use of such contract labour.
- ii) The canteen shall be maintained by the contractor in an efficient manner.
- iii) The canteen shall consist of at least a dining hall, kitchen, storeroom, pantry and washing places separately for workers and utensils.
- iv) The canteen shall be sufficiently lighted at all times when any person has access to it.
- v) The floor shall be made of smooth and impervious materials and inside walls shall be lime-washed or colour washed at least once in each year.
Provided that the inside walls of the kitchen shall be lime-washed every four months.
- vi) The premises of the canteen shall be maintained in a clean and sanitary condition.
- vii) Waste water shall be carried away in suitable covered drains and shall not be allowed to accumulate so as to cause a nuisance.
- viii) Suitable arrangements shall be made for the collection and disposal of garbage.
- ix) The dining hall shall accommodate at a time 30 per cent of the contract labour working at a time.
- x) The floor area of the dining hall, excluding the area occupied by the service counter and any furniture except tables and chairs shall not be less than one square meter (10 sft) per diner to be accommodated as prescribed in sub-Rule 9.
- xi) a) A portion of the dining hall and service counter shall be partitioned off and reserved for
 women workers in proportion to their number.
 b) Washing places for women shall be separate and screened to secure privacy.
- xii) Sufficient tables stools, chair or benches shall be available for the number of diners to be accommodated as prescribed in sub-Rule 9.
- xiii) a) There shall be provided and maintained sufficient utensils crockery,
 1. furniture and
 any other equipments necessary for the efficient running of the canteen.
 2. The furniture utensils and other equipment shall be maintained in a clean and hygienic condition.
 b) 1. Suitable clean clothes for the employees serving in the canteen shall be provided and maintained.
 2. A service counter, if provided, shall have top of smooth and impervious material.
 3. Suitable facilities including an adequate supply of hot water shall be

provided for the cleaning of utensils and equipments.

- xiv) The food stuffs and other items to be served in the canteen shall be in conformity with the normal habits of the contract labour.
- xv) The charges for food stuffs, beverages and any other items served in the canteen shall be based on 'No profit, No loss' and shall be conspicuously displayed in the canteen.
- xvi) In arriving at the price of foodstuffs, and other article served in the canteen, the following items shall not be taken into consideration as expenditure namely:-
 - a) The rent of land and building.
 - b) The depreciation and maintenance charges for the building and equipments provided for the canteen.
 - c) The cost of purchase, repairs and replacement of equipments including furniture, crockery, cutlery and utensils.
 - d) The water charges and other charges incurred for lighting and ventilation.
 - e) The interest and amounts spent on the provision and maintenance of equipments provided for the canteen.
- xvii) The accounts pertaining to the canteen shall be audited once every 12 months by registered accountants and auditors.

10. ANTI-MALARIAL PRECAUTIONS

The contractor shall at his own expense, conform to all anti-malarial instructions given to him by the Employer including the filling up of any borrow pits which may have been dug by him.

- 11. The above rules shall be incorporated in the contracts and in notices inviting tenders and shall form an integral part of the contracts.

12. AMENDMENTS

Government may, from time to time, add to or amend these rules and issue directions - it may consider necessary for the purpose of removing any difficulty which may arise in the administration thereof.

SECTION- XVIII
CONTRACTOR'S LABOUR REGULATIONS

SECTION- XVIII

CONTRACTOR'S LABOUR REGULATIONS

1. SHORT TITLE

These regulations may be called Contractors Labour Regulations.

2 DEFINITIONS

- i) **Workman** means any person employed by contractor directly or indirectly through a subcontractor to do any skilled, semiskilled or unskilled manual, supervisory, technical or clerical work for hire or reward, whether the terms of employment are expressed or implied but does not include any person :-
- a) Who is employed mainly in a managerial or administrative capacity : or
 - b) Who, being employed in a supervisory capacity draws wages exceeding five hundred rupees per mensem or exercises either by the nature of the duties attached to the office or by reason of powers vested in him, functions mainly of managerial nature : or
 - c) Who is an out worker, that is to say, person to whom any article or materials are given out by or on behalf of the principal employers to be made up, cleaned, washed, altered, ornamental finished, repaired, adopted or otherwise processed for sale for the purpose of the trade or business of the principal employers and the process is to be carried out either in the home of the out worker or in some other premises, not being premises under the control and management of the principal employer.

No person below the age of 14 years shall be employed to act as a workman.

- ii) **Fair Wages** means wages whether for time or piece work fixed and notified under the provisions of the Minimum Wages Act from time to time.
 - iii) **Contractors** shall include every person who undertakes to produce a given result other than a mere supply of goods or articles of manufacture through contract labour or who supplies contract labour for any work and includes a subcontractor.
 - iv) **Wages** shall have the same meaning as defined in the Payment of Wages Act.
3. i) Normally working hours of an adult employee should not exceed 9 hours a day. The working day shall be so arranged that inclusive of interval for rest, if any, it shall not spread over more than 12 hours on any day.
- ii) When an adult worker is made to work for more than 9 hours on any day or for more than 48 hours in any week, he shall be paid over time for the extra hours put in by him at double the ordinary rate of wages.
 - iii) a) Every worker shall be given a weekly holiday normally on a Sunday, in

accordance with

the provisions of the Minimum Wages (Central) Rules 1960 as amended from time to time irrespective of whether such worker is governed by the Minimum Wages Act or not.

- b) Where the minimum wages prescribed by the Government under the Minimum Wages Act are not inclusive of the wages for the weekly day of rest, the worker shall be entitled to rest day wages at the rate applicable to the next preceding day, provided he has worked under the same contractor for a continuous period of not less than 6 days.
- c) Where a contractor is permitted by the Employer to allow a worker to work on a normal weekly holiday, he shall grant a substituted holiday to him for the whole day on one of the five days immediately before or after the normal weekly holiday and pay wages to such worker for the work performed on the normal weekly holiday at overtime rate.

4. DISPLAY OF NOTICE REGARDING WAGES ETC.

The contractor shall before he commences his work on contract, display and correctly maintain and continue to display and correctly maintain in a clear and legible condition in conspicuous places on the work, notices in English and in the local Indian languages spoken by the majority of the workers giving the minimum rates of wages fixed under Minimum Wages Act, the actual wages being paid, the hours of work for which such wage are earned, wages periods, dates of payments of wages and other relevant information..

5. PAYMENT OF WAGES

- i) The contractor shall fix wage periods in respect of which wages shall be payable.
- ii) No wage period shall exceed one month.
- iii) The wages of every person employed as contract labour in an establishment or by a contractor where less than one thousand such persons are employed shall be paid before the expiry of seventh day and in other cases before the expiry of tenth day after the last day of the wage period in respect of which the wages are payable.
- iv) Where the employment of any worker is terminated by or on behalf of the contractor the wages earned by him shall be paid before the expiry of the second working day from the date on which his employment is terminated.
- v) All payment of wages shall be made on a working day at the work premises and during the working time and on a date notified in advance and in case the work is completed before the expiry of the wage period, final payment shall be made within 48 hours of the last working day.
- vi) Wages due to every worker shall be paid to him direct or to other person authorized by him in this behalf.
- vii) All wages shall be paid in current coin or currency or in both.
- viii) Wages shall be paid without any deductions of any kind except those specified by the Central Government by general or special order in this behalf or permissible under the Payment of Wages Act 1956.
- ix) A notice showing the wages period and the place and time of disbursement of wages

shall be displayed at the place of work and a copy sent by the contractor to the Employer under acknowledgment.

- x) It shall be the duty of the contractor to ensure the disbursement of wages in the presence of the Engineer or any other authorized representative of the Employer who will be required to be present at the place and time of disbursement of wages by the contractor to workmen.
- xi) The contractor shall obtain from the Junior Engineer or any other authorized representative of the Employer as the case may be, a certificate under his signature at the end of the entries in the "Register of Wages" or the "Wage-cum-Muster Roll" as the case may be in the following form:-

"Certified that the amount shown in column No..... has been paid to the workman concerned in my presence on at"

6. FINES AND DEDUCTIONS WHICH MAY BE MADE FROM WAGES

- (i) The wages of a worker shall be paid to him without any deduction of any kind except the following :-
 - (a) Fines
 - (b) Deductions for absence from duty i.e. from the place or the places where by the terms of his employment he is required to work. The amount of deduction shall be in proportion to the period for which he was absent.
 - (c) Deduction for damage to or loss of goods expressly entrusted to the employed person for custody, or for loss of money or any other deduction which he is required to account, where such damage or loss is directly attributable to his neglect or default.
 - (d) Deduction for recovery of advances or for adjustment of overpayment of wages, advances granted shall be entered in a register.
 - (e) Any other deduction which the Central Government may from time to time allow.
- (ii) No fines should be imposed on any worker save in respect of such acts and omissions on his part as have been approved of by the Chief Labour Commissioner.
Note :- An approved list of Acts and Omissions for which fines can be imposed is enclosed at Appendix-I
- (iii) No fine shall be imposed on a worker and no deduction for damage or loss shall be made from his wages until the worker has been given an opportunity of showing cause against such fines or deductions.
- (iv) The total amount of fine which may be imposed in any one wage period on a worker shall not exceed an amount equal to three paise in a rupee of the total wages, payable to him in respect of that wage period.
- (v) No fine imposed on any worker shall be recovered from him by instalment, or after the expiry of sixty days from the date on which it was imposed.
- (vi) Every fine shall be deemed to have been imposed on the day of the act or omission in respect of which it was imposed.

7. LABOUR RECORDS

- (i) The contractor shall maintain a **Register of persons employed** on work on contract in Form XIII of the CL (R&A) Central Rules 1971
- (ii) The contractor shall maintain a **Muster Roll** register in respect of all workmen employed by him on the work under Contract in Form XVI of the CL (R&A) Rules 1971.
- (iii) The contractor shall maintain a **Wage Register** in respect of all workmen employed by him on the work under contract in Form XVII of the CL (R&A) Rules 1971
- (iv) **Register of accident** - The contractor shall maintain a register of accidents in such form as maybe convenient at the work place but the same shall include the following particulars:
 - a) Full particulars of the labourers who met with accident.
 - b) Rate of Wages.
 - c) Sex
 - d) Age
 - e) Nature of accident and cause of accident.
 - f) Time and date of accident.
 - g) Date and time when admitted in Hospital.
 - h) Date of discharge from the Hospital.
 - i) Period of treatment and result of treatment.
 - j) Percentage of loss of earning capacity and disability as assessed by Medical Officer.
 - k) Claim required to be paid under Workmen's Compensation Act.
 - l) Date of payment of compensation.
 - m) Amount paid with details of the person to whom the same was paid.
 - n) Authority by whom the compensation was assessed.
 - o) Remarks
- v) The contractor shall maintain a **Register of Fines** in the Form XII of the CL (R&A) Rules 1971

The contractor shall display in a good condition and in a conspicuous place of work the approved list of acts and omissions for which fines can be imposed
- vi) The contractor shall maintain a **Register of deductions for damage or loss** in Form XX of the CL (R&A) Rules 1971.
- vii) The contractor shall maintain a **Register of Advances** in Form XXIII of the CL (R&A) Rules 1971.
- viii) The contractor shall maintain a **Register of Overtime** in Form XXIII of the CL (R&A) Rules 1971.

8. ATTENDANCE CARD-CUM-WAGE SLIP

- i) The contractor shall issue an **Attendance card-cum-wage slip** to each workman

employed by him.

- ii) The card shall be valid for each wage period.
- iii) The contractor shall mark the attendance of each workman on the card twice each day, once at the commencement of the day and again after the rest interval, before he actually starts work.
- iv) The card shall remain in possession of the worker during the wage period under reference.
- v) The contractor shall complete the wage slip portion on the reverse of the card at least a day prior to the disbursement of wages in respect of the wage period under reference.
- vi) The contractor shall obtain the signature or thumb impression of the worker on the wage slip at the time of disbursement of wages and retain the card with himself.

9. EMPLOYMENT CARD

The contractor shall issue an **Employment Card** in Form XIV of the CL (R&A) Central Rules 1971 to each worker within three days of the employment of the worker.

10. SERVICE CERTIFICATE

On termination of employment for any reason whatsoever the contractor shall issue to the workman whose services have been terminated, a **Service certificate** in Form XV of the CL (R&A) Central Rules 1971.

11. PRESERVATION OF LABOUR RECORDS

All records required to be maintained under Regulations Nos. 6&7 shall be preserved in original for a period of three years from the date of last entries made in them and shall be made available for inspection by the Employer or Labour Officer.

12. POWER OF LABOUR OFFICER TO MAKE INVESTIGATIONS OR ENQUIRY

The Labour Officer or any person authorized by Central Government on their behalf shall have power to make enquires with a view to ascertaining and enforcing due and proper observance of Fair Wage Clauses and the Provisions of these Regulations. He shall investigate into any complaint regarding the default made by the contractor or subcontractor in regard to such provision.

13. REPORT OF LABOUR OFFICER

The Labour Officer or other persons authorized as aforesaid shall submit a report of result of his investigation or enquiry to the Employer indicating the extent, if any, to which the default has been committed with a note that necessary deductions from the contractor's bill be made and the wages and other dues be paid to the labourers concerned. In case an appeal is made by the contractor under Clause 13 of these regulations, actual payment to labourers will be made by the Engineer after the Employer has given his decision on such appeal.

- i) The Engineer shall arrange payments to the labour concerned within 45 days from the receipt of the report from the Labour Officer or the Employer as the case may be.

14. APPEAL AGAINST THE DECISION OF LABOUR OFFICER

Any person aggrieved by the decision and recommendations of the Labour Officer or other person so authorised may appeal against such decision to the Employer within 30 days

from the date of decision, forwarding simultaneously a copy of his appeal to the Engineer concerned but subject to such appeal, the decision of the officer shall be final and binding upon the contractor.

15. PROHIBITION REGARDING REPRESENTATION THROUGH LAWYER

- i) A workman shall be entitled to be represented in any investigation or enquiry under these regulations by:-
 - a) An officer of a registered trade union of which he is a member.
 - b) An officer of a federation of trade unions to which the trade union referred to in clause (a) is affiliated.
 - c) Where the employer is not a member of any registered trade union, by an officer of a registered trade union, connected with the industry in which the worker is employed or by any other workman employed in the industry in which the worker is employed.

- ii) An employer shall be entitled to be represented in any investigation or enquiry under these regulations by :-
 - a) An officer of an association of employers of which he is a member.
 - b) An officer of a federation of associations of employers to which association referred to in clause (a) is affiliated.
 - c) Where the employers is not a member of any association of employers, by an officer of association of employer connected with the industry in which the employer is engaged or by any other employer, engaged in the industry in which the employer is engaged.

- (iii) No party shall be entitled to be represented by a legal practitioner in any investigation or enquiry under these regulations.

16. INSPECTION OF BOOKS AND SLIPS

The contractor shall allow inspection of all the prescribed labour records to any of his workers or to his agent at a convenient time and place after due notice is received or to the Labour Officer or any other person, authorized by the Central Government on his behalf.

17. SUBMISSIONS OF RETURNS

The contractor shall submit periodical returns as may be specified from time to time.

18. AMENDMENTS

The Central Government may from time to time add to or amend the regulations and on any question as to the application/Interpretation or effect of those regulations the decision of the Employer shall be final.

(Note: Necessary Formats in which records are to be maintained and returns to be submitted shall be provided by the Employer.)

SECTION- XIX
CHECKLIST

SECTION- XIX CHECKLIST

(Please ensure that you have serially numbered each and every page of scanned documents forming your bid and furnished following documents in the manner prescribed mentioning the page number(s) of your bid in appropriate box)

This Checklist should be the first document of your bid numbered as page 1.

CHECKLIST MUST BE FILLED & SUBMITTED BY THE BIDDER

Clause No.	Duly Self Attested following documents	Reference Page No(s) where the documents are uploaded
Section II (ITB Clause 2.9)	(a) Copy of valid registration/enlistment with the respective authorities (Reference: clause 2.2 of eligibility criteria). (SI.No.1 of Section XI)	
	(b) In case of a consortium, certified copy of the agreement between various partners. (Reference : Clause 2.2 of eligibility criteria)	
	(c) Scanned copy of undertaking of having employed the ground water professional during execution of work. (Reference : Clause 2.2 of eligibility criteria)	
	(d) Scanned copy of undertaking as per eligibility criteria 2.2 (e).	
	(e) Current Available Bid Capacity of Bidder duly certified by CA (as per clause 2.2 (f)) with documentary proof of “A value i.e. Maximum value of engineering works executed during any last five year” and “B value i.e. value of existing commitments and ongoing works to be completed in the next “N” years.”	
	(f) Turnover for last three years duly certified by Chartered Accountant. (Reference: Clause 2.3 of eligibility criteria). (SI.No.2 of Section XI)	
	(g) Details of works completed as per table at Sl. No.3 (a) of Section XI. (Reference : Clause 2.4 of eligibility criteria) along with documentary proof	
	(h) Details of payment received for completed works alongwith documentary proof as per table at Sl. No 3(B) of Section XI (Reference : Clause 2.4 of eligibility criteria)	
	(i) Scanned copy of undertaking as per eligibility criteria 2.5	
	(j) Details of Borewells/Tubewells constructed as per table at Sl. No.4 of Section XI. (Reference : Clause 2.6 of eligibility criteria) along with documentary proof.	
	(k) Scanned copy of EMD: As per clause 13 of Section II Instructions to Bidders.	
	(l) Scanned copy of tender fee.	
	(m) Scanned copy of Tender Acceptance letter: As per format in Section XIV	
	(n) Tender document duly signed in all pages, scanned and submitted online alongwith above.	
	(o) Duly Signed copy of Integrity Pact as per format in Section XIV.	
Section II (ITB Clause	(a) Copy of completion certificate and other documents indicating the contract number, amount of the contract and the date of	

2.10	completion in support of details of work submitted by the bidder, duly certified by the competent authority of the respective organisation be submitted. (Reference : Clause 2.4 of eligibility criteria)	
	(b) Documents establishing receipt of payment in respect of details of works submitted by bidder. Form 26 AS of Income Tax returns, bank statement or any other documentary proof clearly indicating the name of the firm/organisations, payment received be submitted. (Reference : Clause 2.4 of eligibility criteria)	
	(c) Following documents duly certified by the organisation under whom the work has been executed shall be submitted (Reference: Clause 2.4 of eligibilitycriteria) Documents in support of number of wells drilled upto a depth of 100 m.	

Signature of Bidder

NOTE: THE BIDDERS SHALL PUT SERIAL NUMBER ON ALL THE PAGES AS PER CHECKLIST BEFORE UPLOADING ON THE PORTAL. BIDDERS WILL BE RESPONSIBLE IF THEIR BIDS BECOME NON RESPONSIVE DUE TO SUBMISSION WITHOUT PAGE NUMBER AND AS PER CHECKLIST.

PERFORMA FOR PERFORMANCE STATEMENT

Proforma for Performance Statement (for a period of last seven years)

Bid No..... Date of opening..... Time..... Hours

Name of Firm.....

Order placed by purchaser	Order No. and Date	Description and quantity of ordered equipment	Value of order	Date of completion of delivery		Remarks indicating reasons for late delivery, if any	Has the equipment been satisfactorily functioning? (Attach certificate from purchaser/consignee)
				As per contract	Actual		
1							
2							
3							
4							
.							
.							
.							
.							
.							

Note:

- A) Delivery means the commencement of supply of data on commissioning
- B) *Performance certificate from the client indicating successful receipt of data for the period from..... To..... from..... no of locations, should be submitted for each order failing which the same will not considered.

Signature and seal of the Bidder

BIDDER INFORMATION FORM

Date: *[insertdate(asday,monthandyear) of Bid Submission]*

Page _____ of _____ pages

1. Bidder's Legal Name <i>[insertBidder'slegalname]</i>
2. Bidder's actual or intended Country of Registration: <i>[insertactualorintendedCountryofRegistration]</i>
3. Bidder's Year of Registration: <i>[insertBidder'syearofregistration]</i>
4. Bidder's Legal Address in Country of Registration: <i>[insertBidder'slegaladdressin countryof registration]</i>
5. Bidder's Authorized Representative Information Name: <i>[insertAuthorizedRepresentative'sname]</i> Address: <i>[insertAuthorizedRepresentative'sAddress]</i> Telephone/Faxnumbers: <i>[insertAuthorizedRepresentative'stelephone/faxnumbers]</i> EmailAddress: <i>[insertAuthorizedRepresentative'semailaddress]</i>
6. Attached are copies of original documents of: <i>[check thebox(es)oftheattachedoriginaldocuments]</i> <input type="checkbox"/> Articles of Incorporation or Registration of firm <input type="checkbox"/> In case of government owned entity from the Purchaser's country, documents establishing legal and financial autonomy and compliance with commercial law <input type="checkbox"/> Included are the organizational chart, a list of Board of Directors, and the beneficial ownership

BIDDER'S JV MEMBERS INFORMATION FORM

1. Bidder's Legal Name: <i>[insert Bidder's legal name]</i>
2. Bidder's JV Member's Legal Name: <i>[insert JV's Member legal name]</i>
3. Bidder's JV Member's country of registration: <i>[insert JV's Member country of registration]</i>
4. Bidder's JV Member's year of registration : <i>[insert JV's Member year of registration]</i>
5. Bidder's JV Member's legal address in country of registration: <i>[insert JV's Member legal address in country of registration]</i>
6. Bidder's JV Member's authorized representative information Name : <i>[insert name of JV's Member authorized representative]</i> Address: <i>[insert address of JV's Member authorized representative]</i> Telephone/Fax numbers: <i>[insert telephone/fax numbers of JV's Member authorized representative]</i> Email Address: <i>[insert email address of JV's Member authorized representative]</i>
7. Attached are copies of original documents of <i>[check the box(es) of the attached original documents]</i> <input type="checkbox"/> Articles of Incorporation (or equivalent documents of constitution or association), and/or registration documents of the legal entity named above <input type="checkbox"/> In case of a Government-owned enterprise or institution, documents establishing legal and financial autonomy. 8. Included are the organizational chart, a list of Board of Directors, and the beneficial ownership.

SECTION XX
CONTRACT FORM

SECTION XX

CONTRACT FORM

THIS AGREEMENT made the _____ day of _____ between
_____ (Name, city, Country) (herein after called “ The Purchaser” of one part and
_____ (Name, city, Country) (herein after called “ The Contractor”) of the other part:

WHEREAS the Purchaser is desirous that certain work/ services should be provided by the contractor, viz. (brief description of work and services) and has accepted a bid by the contractor for Construction of PIEZOMETERS 61 Nos in HARd Rock/Bouldary IN THE UT OF LADDAKH in the sum of (contract price in words and figures)(hereinafter referred to as “ the Contract Price”).

NOW THIS AGREEMENT WITNESSETH AS FOLLOWS:

- 1) In this agreement words and expression shall have the same meanings as are respectively assigned to them in the conditions of contract referred to.
- 2) The following documents shall be deemed to form and be read and construed as part of this agreement:
 - a) The Technical Bid and the Price Bid submitted by the Bidder,
 - b) The Requirement of work,
 - c) The Technical Specifications,
 - d) The General Conditions of Contract,
 - e) The Special Conditions of Contract, and
 - f) The Purchaser’s Notification of Award.
- 3) In consideration of the payments to be made by the Purchaser to the Contractor as hereinafter mentioned, the Contractor hereby covenants with the Purchaser to provide the works and services and to remedy defects therein in conformity in all respects under the provisions of the Contract.
- 4) The Purchaser hereby covenants to pay the Contractor in consideration of the provision of the Goods and services and the remedying of defects therein, the Contract Price or such other sum as may become payable under the provisions of the Contract at the times and in the manner prescribed by the Contract.

IN WITNESS WHEREOF THE parties hereto have caused this Agreement to be executed in accordance with their respective laws and day and year first above written.

Signed, sealed and delivered by the
Said _____(For the Purchaser)
In the presence of _____

Signed, sealed and delivered by the
Said _____(For the Supplier)
In the presence of _____